

Disaster Resistant Housing
In
Pacific Island countries

**A compendium of safe low cost housing practices
in Pacific Island Countries**

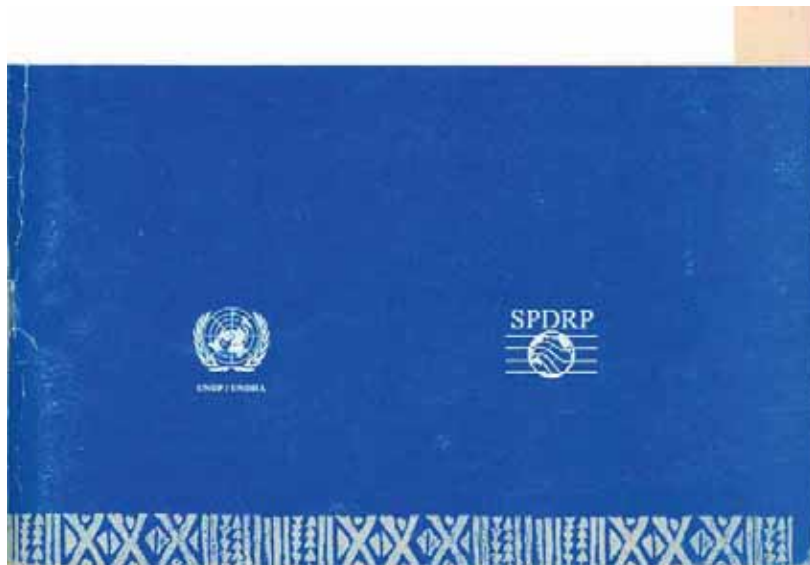

Disaster Resistant Housing in Pacific Island Countries

**A compendium of safe low cost housing
practices in Pacific Island Countries**

March 1998



prepared by Luc Vrolijk

for the South Pacific Disaster Reduction Programme (RAS/92/360)

under consultancy arrangement with
UN Department for Economic and Social Affairs,
New York

Table of Contents

Foreword

1. Introduction	1
2. Problems: What goes wrong	4
2.1. Tropical cyclones	4
2.2. Earthquakes	6
3. Principles for safe construction	9
3.1. Cyclones	9
3.2. Earthquakes	12
4. Construction for new houses	14
4.1. Wood frame houses	15
4.2. Traditional and semi-traditional houses	31
4.3. Concrete block houses	36
4.4. Safe roof constructions	43
5. Strengthening of existing houses	57
5.1. Making a plan for improvement	57
5.2. Progressive upgrading measures	57
6. Pre-disaster precautions	61
7. Elected designs	62
7.1. The Tongan hurricane relief housing	63
7.2. Cyclone resistant houses, Public Works Department, Vanuatu	65
7.3. Standard timber houses, Regional Development Department, Fiji	68
7.4. Ezi build kit home, FIJI	69
7.5. Standard concrete block house, Regional Development Department, Fiji	71

8. Housing improvement programmes	73
Annexes	76
Annex 1: List of persons consulted	76
Annex 2: Literature	80
Annex 3: References per section	82
Annex 4: Abbreviations	87

Foreword

Natural hazards are a serious threat for the sustainable development of Pacific island countries. Their impact disrupts the lives of the people in the Pacific and every year there are lives lost and properties damaged due to cyclones, floods, earthquakes or landslides.

Reduction of disaster risks is a priority for the United Nations system. In order to emphasise this and to stimulate programmes to reduce disaster impacts world-wide, the United Nations General Assembly designated the 1990s as the International Decade for Natural Disaster Reduction. The Decade programme has increased awareness of the importance of disaster reduction for sustainable development. Numerous publications, projects, programmes and other activities were implemented. These have demonstrated that practical ways and means exist to reduce the exposure of people and societies to natural hazards.

In Pacific island countries, the United Nations system assists countries to reduce disaster impacts through the South Pacific Disaster Reduction Programme. This programme is funded by UNDP and eight bilateral donors. The UN Department of Humanitarian Affairs implements the activities through its South Pacific Programme Office. The programme provides institutional support, technical assistance and other support for disaster preparedness, mitigation and prevention. The first phase of the programme is completed at the end of 1997. The second phase will place even more emphasis on giving direct support to communities in reducing risk exposure.

The compendium of safe low cost housing practices was prepared as part of the South Pacific Disaster Reduction Programme. It demonstrates the principles and technical features of safe low cost housing. It shows that there are feasible ways of reducing the damage to houses as a consequence of cyclones and earthquakes. The compendium intends to consolidate the experiences that have been gained in the region over the last decade or so. It builds on the lessons and programmes of the past in order to show future builders and house owners what they can do to reduce the impacts of disaster in their own environment.

The compendium is not an aim in itself. It groups and consolidates existing knowledge in order to make it better accessible or present day builders. It is hoped that the compendium will contribute to a wide range of housing improvement programmes in the region, including training programmes, national housing strategies etc. The UN system will continue to provide support to this process.



Romulo Garcia,
UNDP Resident Representative,
Suva, March 1998

The compendium is prepared as part of the South Pacific Disaster Reduction Programme, a regional technical cooperation programme which is implemented by the UN Department of Humanitarian Affairs, South Pacific Programme Office, with funding contributions of UNDP and eight bilateral donors. The compendium was funded under the UNDP component of the programme (*RAS/92/360*) and can serve as a resource for individual builders as well as national and regional disaster management and housing construction programmes. As part of the preparation process, consultations and field visits were held in five Pacific island countries: Tonga, Western Samoa, Solomon Islands, Vanuatu and Fiji.

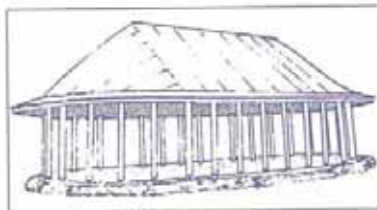

a traditional Fale, Western Samoa

The publication focuses on safety measures and features that help to protect against tropical cyclones and earthquakes. The cyclone hazard is the most frequent to affect the people of the Pacific and housing damages are almost always a considerable part of the suffering. The earthquake hazard, though much less frequent, can have a devastating impact. On average, around 80% of the deaths caused by earthquakes are caused by collapsing buildings. Most of the other hazards are less frequent or damaging, or their mitigation is mainly a matter of finding suitable locations rather than of the structural integrity of buildings. This is the case for both landslides and floods.

The study focuses on low cost housing. It addresses simple basic family houses that are often constructed without the help of engineers or architects. This type of housing forms the vast majority of housing in the region, and it is here that most of the damages occur. The publication does not cover multi-storey buildings, as these should in general be designed by an engineer in accordance with formal building regulations.

This study is concerned with the actual dwelling. Aspects like location, urban growth, planning and community participation are discussed in other publications prepared in the South Pacific Disaster Reduction Programme.

Technical information is kept to a minimum. The main principles and some key examples are given and reference is made to other publications where relevant. The presented measures and designs are a mixture of 'traditional' and 'modern' construction practices, as is the situation in present day housing in the region. Traditional housing is still widespread, in particular in the Melanesian countries, but even there new tools and practices are implemented on a wide scale. The many valuable lessons that can be drawn from traditional construction practices can be re-interpreted in order to be of use on a wide scale in this day and age.

The compendium uses many illustrations to introduce and elaborate the key principles, problems and practices. It aims to be understandable, also for the non-technical reader.

The structure of the compendium is as follows:

- Chapter 2 discusses what often goes wrong in a disaster.
- Chapter 3 introduces the principles of safe construction.
- In Chapter 4, the designs of buildings are discussed in relation to their sensitivity to disasters. Construction details for dominant housing types are presented and discussed.
- Chapter 5 outlines the measures that can be taken to improve existing houses.
- Chapter 6 summarises the precautions that can be taken immediately before a cyclone strikes.
- In Chapter 7, some selected 'standard designs' for Pacific safe low-cost houses are shown.
- Chapter 8 gives some building blocks for the establishment of housing improvement programmes.



new house in Fiji

2. Problems: what goes wrong

This chapter outlines the main housing problems that occur in tropical cyclones and earthquakes in the Pacific. This forms the basis for looking at safe housing construction principles.

2. 1. Tropical cyclones

The overriding problem in withstanding the high winds of a tropical cyclone is that the connections between the different elements of the building get damaged. Because of that the structural integrity or coherence of the building diminishes and the house, or parts of it are destroyed. The key word in cyclone mitigation is 'connections' most of the problems are caused by poor connections between different elements of the building.

The problem of connections is vital to all parts of the building:

1. The roof iron or other cladding material can be pulled off from the structure by the strong wind. Insufficient roofing nails or the use of non spiralled nails are the main cause of this damage;
2. The wind can also pull off the roofing iron together with the purlins it is attached to, this is caused by insufficient strapping between purlins and rafters;
3. The wind circulation, which pulls on the roof as a whole, can blow off the entire roof structure. The forces of the wind depend on the shape of the roof. Insufficient strapping between roof structure and walls can cause the loss of the roof;
4. The wind force can also destroy the structural integrity of the roof structure itself, which is caused by insufficient strapping of the different elements of the roof structure;

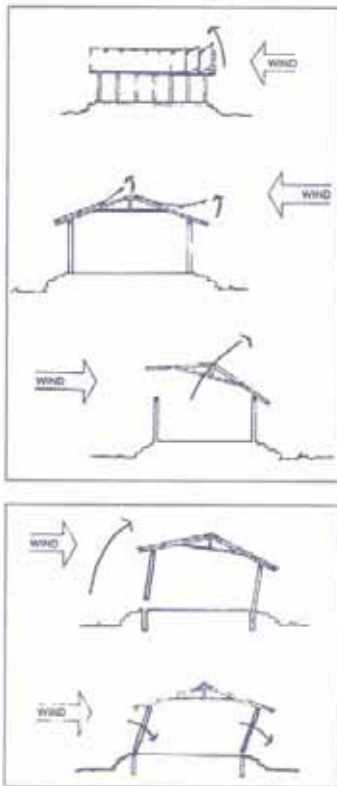

5. The last connection that can be damaged is that between the walls and the foundation, causing the whole building to be lifted (or shifted) from its foundation;
6. The direct pressure of the wind against the walls (and the pull force on the other side), has to be withstood with diagonal braces or interior walls. Where these are lacking, or insufficiently strong, the whole house can be pushed to the ground.

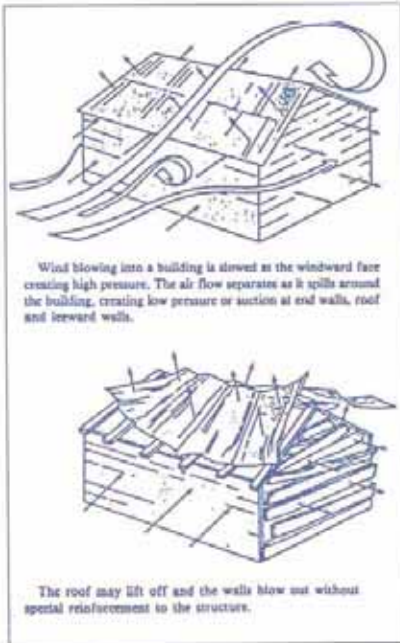

How a cyclone damages a building

2.2 Earthquakes

There are four basic causes for earthquake induced damages:

Hazards

Ground shaking is the principle cause of damage earthquake induced accelerations and displacements can damage or destroy a building unless it has been designed and constructed to be earthquake resistant;

Ground failure can take different forms; ground rupture along the fault zone, landslides, settlement and soil liquefaction. Landslides are an important threat in the region. Soil liquefaction can also be important, especially for heavy structures on alluvial soils. It causes buildings to sink because the bearing capacity of the soil is reduced to almost zero.

Tsunami is a series of sea waves that are caused by an earthquake or volcanic eruption on the seabed. Their damage potential depends on the shape of the sea floor and the topography of the land. Close to shore they can cause heavy loss of life, even if caused by earthquakes on the other side of the Pacific. For local tsunamis there is almost no warning time and their impact can be devastating.

Fire is the fourth major damaging agent of an earthquake. Especially in densely populated areas with timber houses, damages and loss of life can occur.

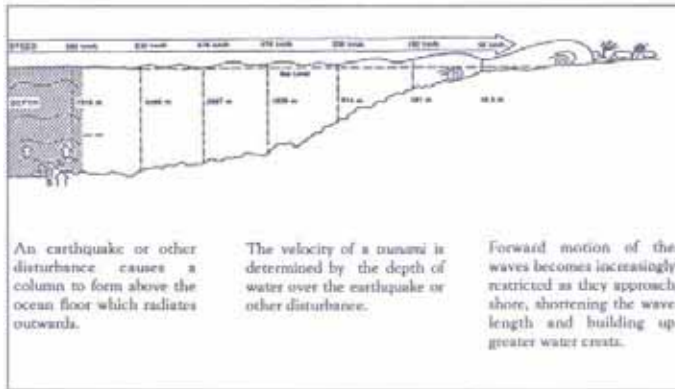

Development of a tsunami

Vulnerabilities

The main factors that affect the level of damage that a building suffers are:

Site condition: the intensity of the shock is directly related to the type of soil layers supporting the building

Building configuration: regularity and symmetry in the overall shape of the building make it stronger

Opening sizes: openings weaken the building; large openings can be a direct cause of damage

Rigidity distribution: the rigidity of the building needs to be evenly distributed; columns and walls should best run from the foundation to the roof

Ductility: ductility is the capacity of the building to bend, sway and deform without collapse. Timber buildings with strong connections have this capacity, but brittle buildings like brick and concrete block crack easily, which can lead to collapse

Construction quality: poor construction and poor workmanship are a major cause of damage

Weak ground floors: two storey buildings can be very vulnerable to earthquakes. Especially when the building has a soft ground floor (only pillars, no walls) the risks can be very high.

The following can be seen as a broad indication of the overall earthquake vulnerability of the low cost housing covered in this compendium:

Roofs: generally light roofs are applied in the Pacific; this reduces the vulnerability. When strapped to cyclone specifications, the roofs will normally be able to withstand earthquakes

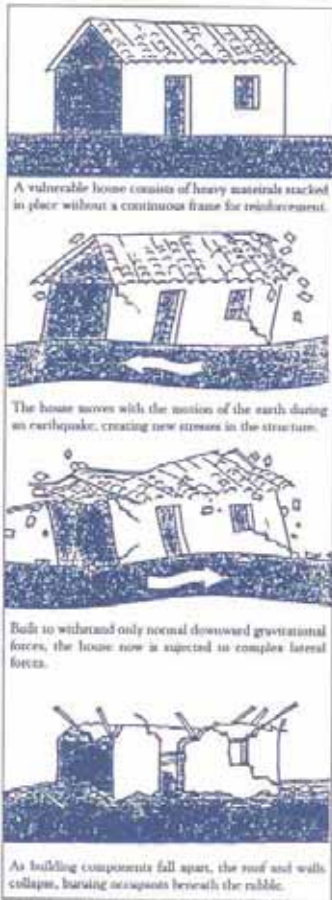

How an earthquake damages a house

Timber buildings: in general timber houses can stand up well during an earthquake. Main problem is that they are often constructed on short poles. Risk is that the building is shook from its foundation.

Traditional houses: the resistance of traditional houses is often very good in an earthquake. The buildings have a high ductility and when proper strappings are applied, they will be able to withstand most earthquakes.

Concrete block houses: when properly built, a concrete block house is sufficiently strong to withstand an earthquake. However improper construction can make this type very vulnerable. The most important elements are the ring beam, vertical and horizontal reinforcement and strong corners.

3. Principles for safe construction

⁹ This chapter outlines the broad principles for safe construction of new houses. These principles are relatively simple and straightforward. Adherence to these principles forms the basis of safe housing construction.

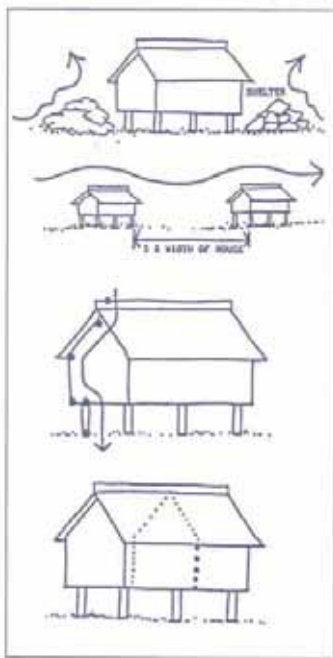

3.1 Cyclones

The principle method in building cyclone resistant houses is to tie down the roof to the walls, the walls to the floor, the floor to the stilts and the stilts to the foundations. Also, the walls must be strong enough to prevent the wind blowing them in, and the joints must be strong enough in order that the wind cannot lift off part or all of the roof or knock the house over.

The following are the main principles for safe construction against cyclones:

Sitting: do not build at the head of the valley or on the side of an exposed hill where the wind speed can be much stronger;

Location: take advantage of natural protection such as rocks, banks and strong bushes or plant strong bushes nearby the house;

Planning: build a short distance away from the other houses and never directly next to them as this can cause destructive wind turbulence;

Tie the structure to the ground: connect the roof, the walls to the floor; the floor to the stumps or stilts and these to the foundations, creating a chain of anchorage;

Support walls where possible: build internal walls to brace the outside walls and prevent them from caving in;

Brace all walls and roof: brace all the walls, and across the corners of the walls and diagonally across the underside of the roof with timber braces to make the walls stiff;

Make strong connections: ensure that all structural members are securely connected. Using only nails is not good enough; there should be a bracing of wire, vine or other material;

Join parts together securely: use construction joints which are notched and tied together. There needs to be sufficient overlap and a strong bracing;

Roof pitch: pitch the roof to rise at least one foot for every three foot. This reduces the forces on the roof and makes the roof stronger;

Avoid wide overhangs and eaves: make overhangs small, less than 600 mm. and eaves less than 400 mm;

Verandas: the wind can be trapped beneath the veranda; therefore it should be connected in a way that the veranda can break away separately from the main structure;

Loose edges: tie down the edges and corners of the roof so that the wind cannot attack one part and tear it away;

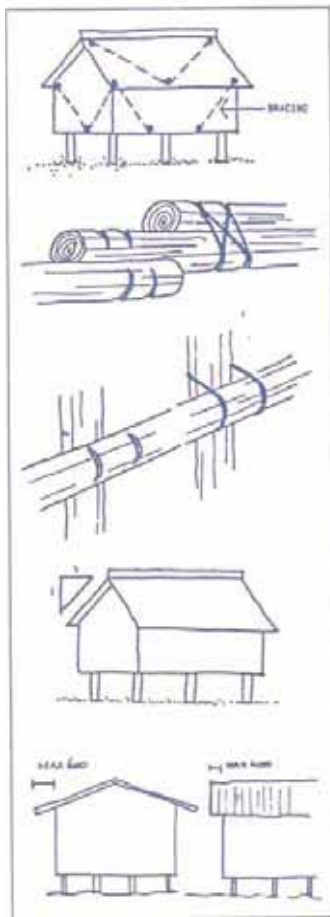

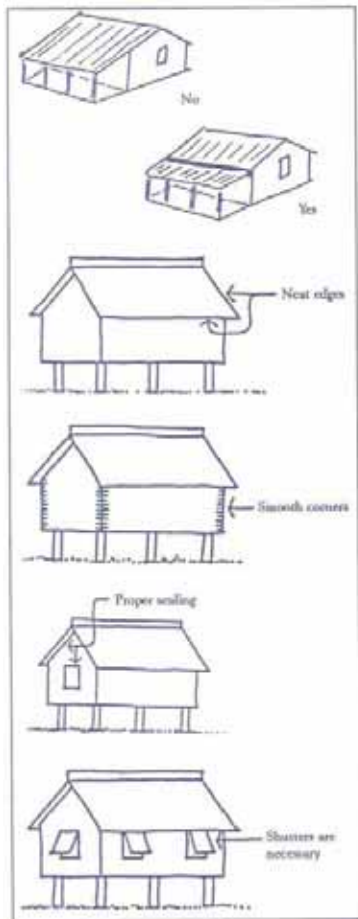

Smooth corners: smoothen corners of the house in order to allow the wind to slide around;

Weathering details: seal edges of window openings and where the roof meets the walls to prevent rain and wind from entering;

Closing off windows and doors: close of window and door openings with firm shutters when a cyclone approaches;

10. 3.2 Earthquakes

The following are the main principles to be considered in earthquake resistant housing:

Location

Stability of slope: only stable slopes, without signs of previous landslides, should be chosen to build; a site subject to danger of rock fall should be avoided as well;

Soil types: avoid constructing on very loose sands or sensitive clays; these can compact or loose their bearing capacity in an earthquake and cause large unequal settlement and damage or destroy the building;

Shape of building

Symmetry: the building as a whole or its various blocks should be kept symmetrical about both axes; asymmetry leads to torsion and danger of collapse. Symmetry is also desirable in the placement and sizing of door and window openings as far as possible; shape of a building

Regularity: simple rectangular shapes behave better in an earthquake than shapes with many projections. Torsional effects of ground motion are pronounced in long narrow rectangular blocks; therefore it is desirable to restrict the length of a block to three times its width;

Simplicity: ornaments should be avoided; they can fall off and cause injuries;

Enclosed area: a small building enclosure with properly interconnected walls will act like a rigid box; very long rooms should be avoided; use enclosed areas

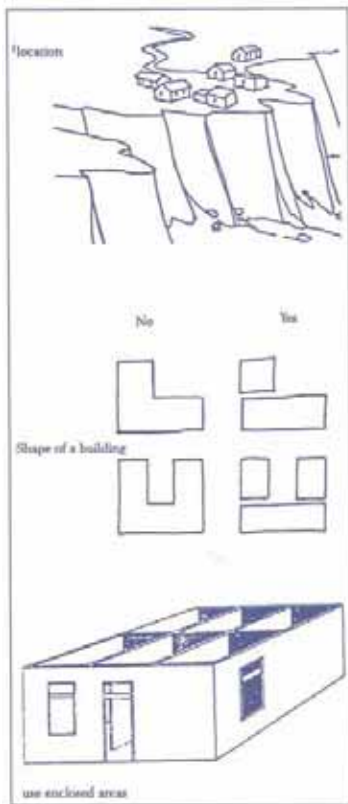



Foundations: strong wall to ground connections are necessary and a complete concrete or rock foundation is preferred; construction on short columns should be avoided because the house is often shaken from its footing;

The problem of stilts

Stilts: Two storey buildings on stilts are very unstable when the ground floor is not filled in. They are likely to collapse, even in moderate ground shaking. this type of construction should be avoided in earthquake prone areas; ground floors should be filled in first;

Construction

Openings: openings should be constructed away from corners; moreover; the total length of openings should not exceed 50% of any single wall;

Ring beam: the most important horizontal reinforcement of the house is the construction of one or more ring beams to connect together all walls of the house. These beams can be located at all critical levels of the building, namely plinth, lintel, roof and gables;

Walls: depending on the material applied, diagonal braces and horizontal beams are necessary to give the walls sufficient stiffness to resist earthquake force;

Concrete block walls: use enough vertical reinforcement and fill all openings with mortar; use sufficiently strong mortar, with a cement:sand mix of 1:6;

Connections and joints: connections and joints should be strong. For timber construction, braces are necessary to keep the construction together: When using reinforced concrete blocks, there should be sufficient overlap of reinforcement steel;

Roof: use light roof constructions, with timber and irons sheeting or traditional materials;

4. Construction of new houses

Most of the new houses constructed in Pacific island countries are (i) timber frame houses; (ii) traditional houses with round poles or (iii) concrete block houses. Mixtures of traditional and 'modern' timber houses are also frequently built. Corrugated iron roofs are by far the most dominant type of roofing, although in the Melanesian countries thatched roofs are frequently applied.

This chapter describes how these housing types can be constructed in a safe way. Roof construction and detailing are described separately because most roofs are of the same type, and damage to roofs is the most common damage.

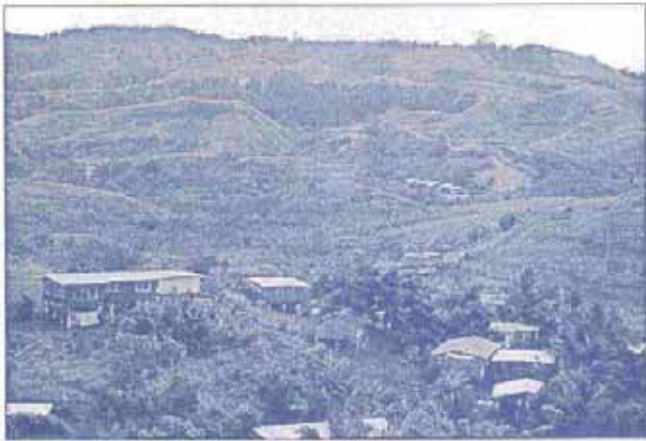

4.1 Wood frame houses

Building process



Wood frame house in Nuku'alofa, Tonga

Wood frame houses are the most widespread construction form in the region. This housing type can very well be constructed to stand up against cyclone damages. Main requirement is the proper strapping and bracing of the structure. When build to cyclone specifications, timber houses can normally withstand an earthquake.

The process of constructing a simple wood frame house is illustrated here in strip form. This process was first described for the Solomon Islands, but similar construction forms are applied around the region. This already gives the main features and rules that should be followed in construction.

After that, more detailed information is given for the various construction elements, including technical details. The roof construction is discussed separately.



Use string to lay out the house



Strings mark the location of post



Dig post holes



Cut post



Paint them with wood preservative



Set post two feet deep or more



Make bearers using two 6 x 2's

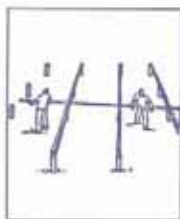

Set bearers on posts

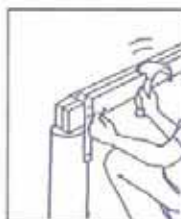

Fasten bearers to posts using metal straps



Put floor joists in place



Fasten joists to Bearers with straps



Nail floor boards to joists



Nail studs to top and bottom plates on the ground



Stand up walls

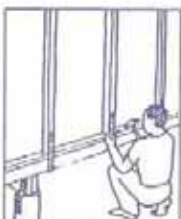

Fasten studs to joists with straps



Nail corner braces



Put braces in all corners



Put diagonal braces in corners, fasten with straps.



Make door frame



Make window frame

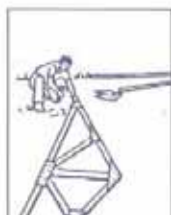

Make roof truss



Put truss on wall



Fasten truss to wall with straps



Nail purlins in place



Nail tight



Use straps to add strength



Set rafters at veranda



Nail purlins to rafters



Use straps to add strength



Nail roof sheets to roof frame



Put nail in each ridge of tin sheet



Nail siding onto the frame



Saw and nail boards to make strong shutters

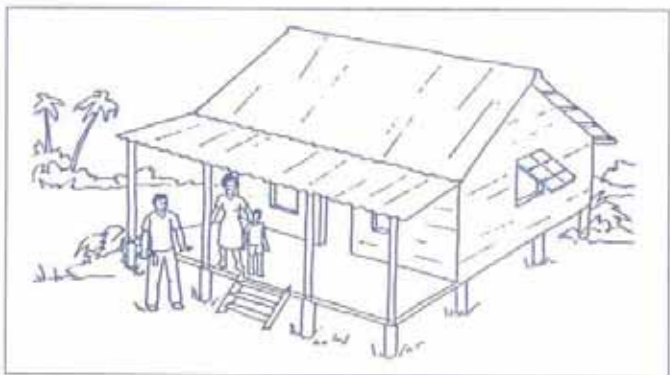

Construction details

This section discusses the main features for safe construction of a simple timber house. The following issues are discussed:

- construction of houses with timber floors, including the fixing of ground posts, use of concrete piles; length of posts; spacing of posts
- bracing of piles, and post to floor connections
- construction of timber houses with concrete floor foundations
- construction of walls, including ring beam, wall connections, bracing and roof to wall connections

As indicated, roof details are discussed separately.

Overview of a wood frame house

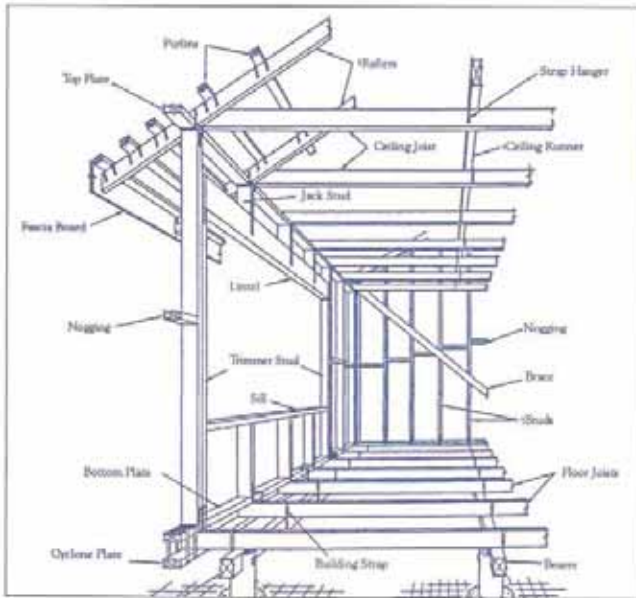

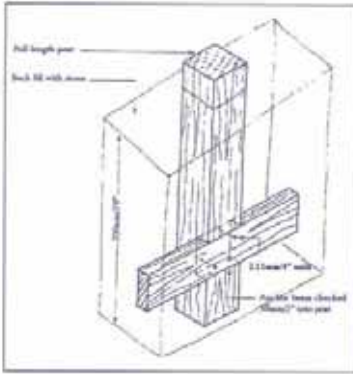

Wooden post with anchor beam

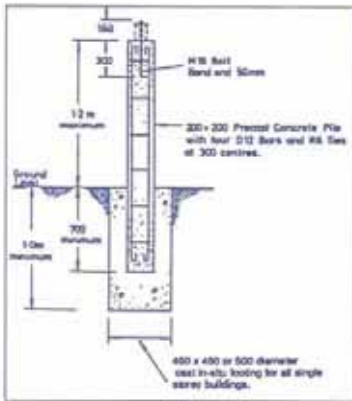

Detail of a pre-cast concrete pile

Fixing ground posts

To prevent the house from being lifted from the ground, the foundation must be securely fixed. There are various ways of achieving enough strength:

1. **Spacing of piles:** sufficient posts should be used to spread the forces of wind or earthquake. A common spacing between posts is around 3 meters. Sometimes short posts are used in between to support the floor;
2. **Depth of foundation:** the post should go deep enough into the ground in order to have enough friction not to be pulled out by cyclone winds. Minimum depth, also depending on soil type is 0.6 to 0.9 meter.
3. **Backfill of posts:** the posts should be backfilled with rock, which is rammed in the soil around the post;
4. **Anchor beam:** a way of adding additional strength is to fix an anchor beam just above the foot of the post. The anchor beam can be fixed with cane or wire, or bolted to the post.
5. **Cast in concrete:** a secure way of fixing the post into the ground is to cast it in concrete. Condition is that the post should be surrounded by concrete; the foot of the pillar should be wider than the top, and the wooden post should be well fixed in the concrete, e.g. with bolts that are cast in the concrete. Last condition is that the right concrete mix is used.

Concrete piles

An alternative for the use of wooden foundation piles is the use of short concrete piles. Their depth should be the same as for wooden piles. Most important

detail with concrete piles is the connection of the floor to the piles. The piles should have provisions for proper fixing of the floor beams, mostly in the form of bolts that are cast in the pile. The use of short concrete piles can be dangerous in earthquake risk areas; it is recommended that foundations with wooden posts are used there (these can be cast in concrete).

Short posts or full length

In some countries (e.g. Fiji and Samoa) it is common practice to use short posts and construct the house floor on the stumps. In other locations, full length posts are used: one post from the foundation to the roof. Both methods can be applied safely. The use of one single post from soil to roof makes it strong in an earthquake or cyclone, but with proper bracing and fixing, short poles can also be applied safely.

Anchor piles and floor piles

A difference can be made between anchor piles and floor piles. Anchor piles bear walls and the roof, while floor piles only carry the floor. Spacing of anchor piles depends on the loads, but is generally around 3 meter under walls and maximum 6 meter overall. Fixing of anchor beams or other ways of dealing with uplift forces are necessary for anchor piles.

Space between ground and timber floor

To prevent the floor from rotting, and to provide cross ventilation, the timber floor should be build around 0.5 meters above the ground. The space between floor and ground should be ventilated. However; to prevent cyclone winds from uplifting the building, planks with at least 2 cm in between can be used to cover the sides of the house. In earthquake prone areas, shorter poles would make the building more vulnerable as well.

Bracing of piles

When the floor is more than 1 meter above the ground, the piles should be braced. Bracing should always be done in two directions, and generally on all four corners of the house. The number of braces depends on the floor height and the design wind speed and/or earthquake force.

The most common form of bracing is by using timber; but the same effect can be achieved by building corner foundation walls.

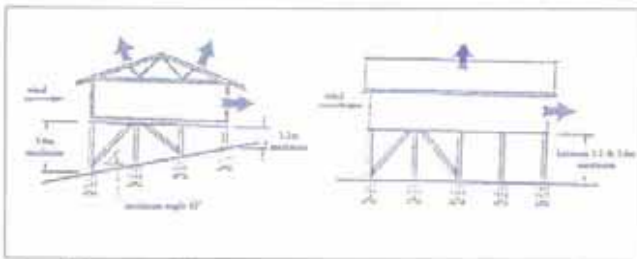

Bracing of piles to resist wind forces

Details of a concrete block corner foundation wall

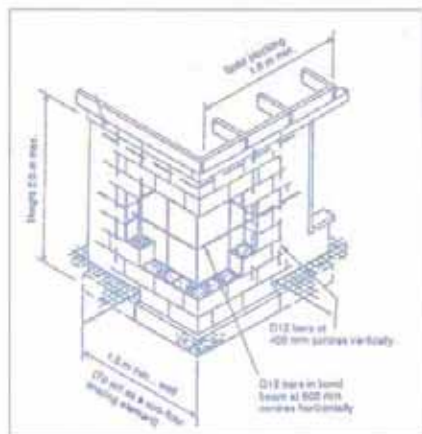

Bracing schedule for a wooden frame house

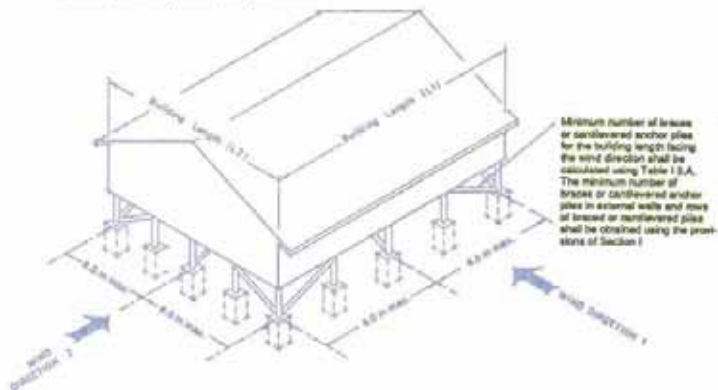

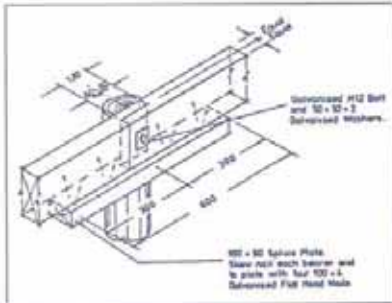

Fixing floor bearers to wooden post with 12 mm. bolt+washers

Post to floor connections

A strong fixing of the posts to the floor is a basic condition for the house to withstand a cyclone or earthquake. The floor bearer should be tightly fixed to the posts and the floor joists should be strapped to the bearers. The choice of method mainly depends on the available budget. Methods include the following:

1. **Bolts:** 12 mm. bolts can be used safely to fix the bearers to the posts. it is important to apply washer.
2. **Traditional straps:** each country has its own traditional material to tie parts of the house together. Important is that the strap is well fixed and cannot unravel under force.
3. **Steel wire:** galvanized steel wire can also be used; beginning and end of the strap should be fixed in the post with a nail, around which the wire has to be turned; generally 2-4 loops of wire are needed.
4. **Ready made straps:** there is a wide choice of ready made straps available in most countries of the region; some examples are given here.

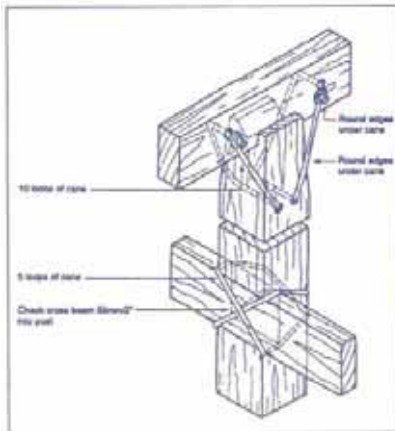

Post to floor connection using traditional straps

Ring beam

A ring beam that joins together all floor joists adds additional strength to the connections between floors and walls. It makes the floor react like one element and makes it easier to make strong connections between walls and floor. A principle detail is given here. Mostly, ready made straps are used to tie the top and bottom plates together.

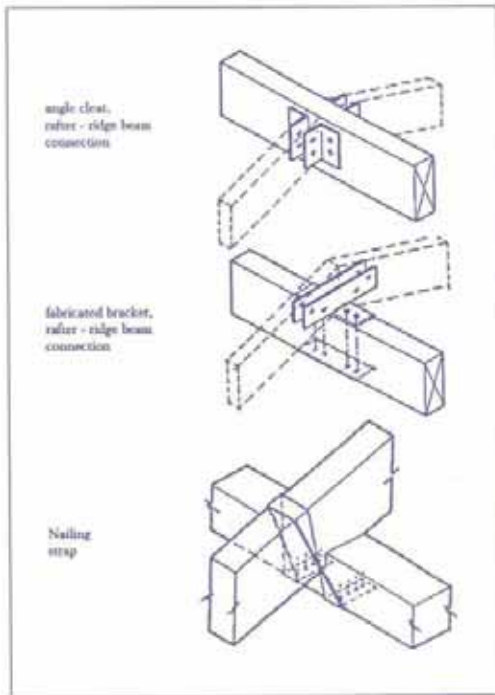

Examples of ready made straps

Concrete floor foundations

In some countries, notably in Vanuatu and some of the Micronesian countries, timber houses are constructed on concrete floor slabs. This type of floor should be properly founded in order to be able to transmit the forces on the walls down to the ground. The most important detail for this type of construction is the way in which the walls are fixed to the floor. When this fixing is not strong enough, a cyclone can blow the building off its foundation, or it will be shifted by an earthquake.

Details of a timber ring beam and listel

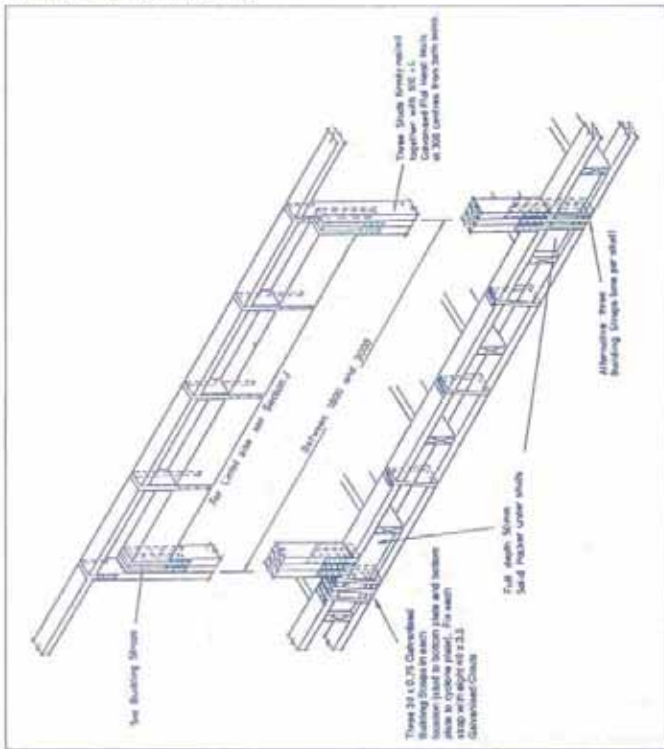

In case of a concrete floor foundation, normally a ring beam is bolted to the concrete to serve as a base for fixing the posts. The strappings that connect the post to the beam should continue under the beam and should thus be placed before the beam is fixed.

Bracing of walls

Timber frame walls consist of a bottom plate, top plate, vertical studs, horizontal nogs, a diagonal bracing and horizontal or vertical weatherboards. These elements together provide the strength to resist horizontal wind forces. The number of braces needed depends on the design of the building. For a standard family home, bracing of the four corners is sufficient.

Braces should always be made in two directions to allow wind from all sides to be resisted. Instead of timber braces, metal braces can also be used. They can be purposely made from metal strips or ready made purchased. Metal braces should be applied in both directions within the same wall.

The necessary stiffness of the wall can also be achieved by applying at least 16 mm plywood as weatherboard. This should be one element from bottom to top and fastened vigorously.

Diagonal braces to the fix together the top plates of two walls should be added for additional strength.

Wall to floor connection details

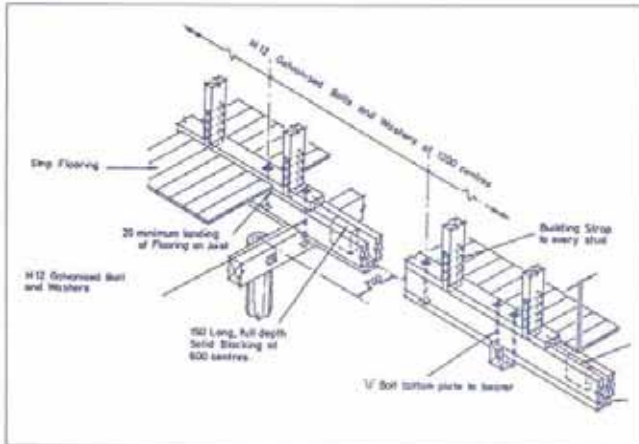

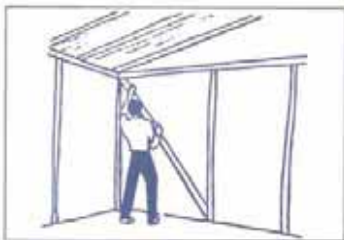

Braces should be placed in all four corners.

Interior walls

Interior walls help outside walls to resist the direct horizontal pressure of the wind. They act as a bracing panel for the outside wall. It is necessary to have such panels at least every 6 meters. If the house is longer than 6 meters, a separate bracing panel of at least 1.2 meters width or a braced internal wall is needed.

The interior walls can be constructed in a similar manner as described above. Only the end posts need to be strapped for interior walls.

Wall to roof connections

The connection between roof and wall is one that often causes problems, leading to the loss of the roof in a cyclone. The top plate of the wall should be properly strapped to the posts. The roof construction needs to be strapped to the top plate, preferably on top of, or close to a stud.

More details on roof constructions are given in 4.4

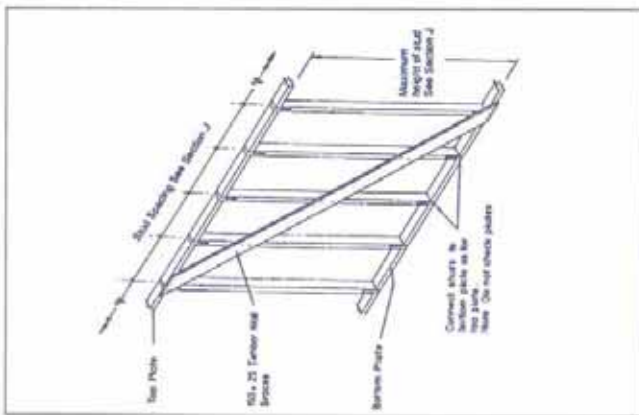

Connection of braces to the wall

Connection detail with building strap

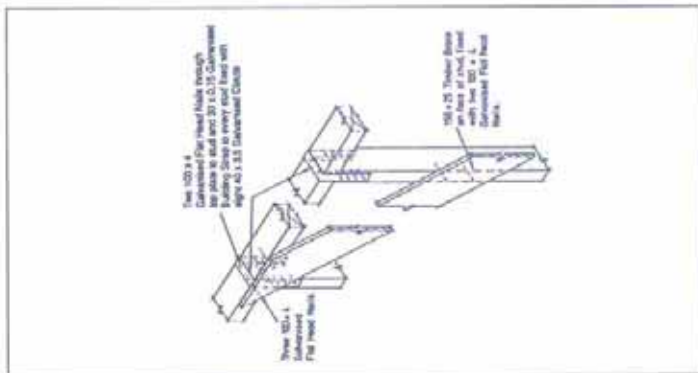

Interior wall construction

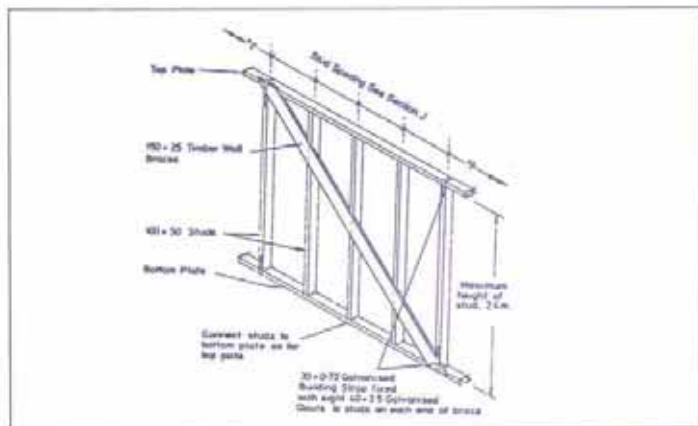

4.2 Traditional and semi-traditional houses



Traditional village in the Solomon Islands

There is a rich variety of traditional houses in Pacific island countries. The extent to which traditional construction is still applied varies widely in the region. In the Cook Islands, Tonga and Marshall Islands, traditional housing is becoming scarce, while in PNG, Solomon Islands and Yap, traditional materials and construction types are still dominant.

It is difficult to make a sharp separation between 'traditional' construction and disaster resistant 'modern' housing. Many of the principles for safe construction have been learnt from traditional construction methods.

In all countries, the shapes and forms of 'modern' buildings is evolved from tradition, and traditional buildings are increasingly constructed with 'modern' materials.



Traditional Tongan Fale

In terms of the principle details for construction, there are many similarities between traditional' and 'modern' timber construction. The main approaches to safe construction are discussed in the previous section. This section only supplements section 4.1 with some of the particular features related to traditional construction.

It first discusses some features of traditional housing and shows the variation in their inherent vulnerability.

This is followed by a discussion of mixed forms of construction, where traditional materials are used in combination with 'modern' tools and techniques. Finally, some details are shown how a strong, safe house can be constructed with traditional materials. These details complement the details for timber construction that are given in the previous section.

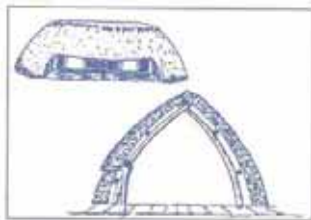

Traditional Ni Sumu in Vanuatu



Traditional house in Timor

An example: Fijian bure

In the more cyclone prone areas, traditional houses are particularly well adapted to cope with the cyclone hazard. Traditional housing in the Pacific is also well adapted to cope with earthquakes because of their ductility, or ability to bend and sway without collapse.

The following description of the traditional Fijian house (or bure), shows many of the qualities that were incorporated in traditional construction:

In traditional Fijian bures, strong wooden corner posts are set in the ground and a wooden roof frame is erected on top of the posts to create the building frame. Mats of woven bamboo or reeds are attached between the corner posts to make the walls. These are often supported by small vertical posts which help to reinforce the walls in the centre. Traditionally, the house is bound together with ropes made from coconut fibre or other natural materials, but in recent years construction wire has been used.

Bures normally have a thatched roof made from pandanus (or in some cases palm leaves). Almost all roofs are high and use a hipped (4-sided) configuration.

These bures are quite strong. They bind the building together with ropes or wire. The configuration of the building is strong and the pitch of the roof is excellent. The corner posts are normally fairly strong and buried sufficiently to resist uplift. When damaged, bures are difficult to repair and most residents usually rebuild a new structure. However even total collapse of the bure is rarely lift-threatening. The roof usually blows off the structure intact, and it is common practice that the occupants then rush outside and crawl under the roof for the remainder of the hurricane.

The main features of the traditional Fijian bure concur to the principles set out in chapter 3: strong posts, connections with ropes, a steep, hipped roof and simple building plan. Traditional buildings in among others Vanuatu, Tonga, Palau and Cook Islands have similar characteristics.

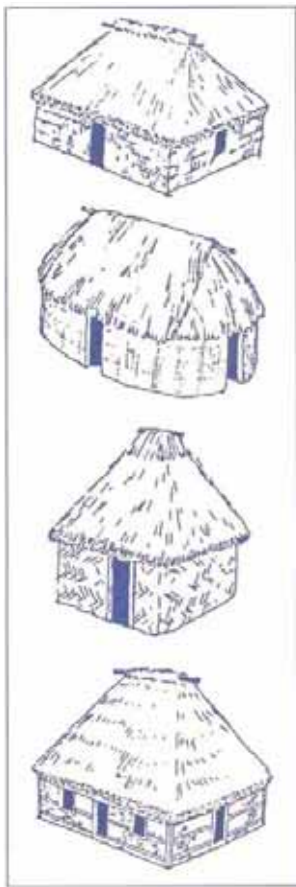

Various types of traditional Fijian bures

5. Comparison: Tuvalu



Various types of traditional houses in Tuvalu

apply traditional vines that are found in the bush. It is recommended to use steel wire for strapping when applying steel roofs.

Construction details

The principle construction details are similar to those applied in the construction of sawn timber houses, as discussed in 4.1. Key is to tie together all parts of the house, creating a chain of anchoring from the roof to the foundation. This helps to resist the uplift forces. In addition, bracing is

In less exposed countries, traditional housing types are sometimes more vulnerable because other qualities are considered more important.

An example is Tuvalu, where traditional houses are very open to enable ventilation for cooling. Despite the fact that the construction methods are excellent and strong, the design itself makes the traditional Tuvaluian fale highly susceptible to high winds. The openness of the building is the primary problem. With that much exposure, the roof will not be able to sufficiently resist uplift, and the entire building will usually fail.

Another feature of traditional construction in Tuvalu is that coral blocks are often used for the construction of walls. Adding strong reinforced concrete block corners to these building types is considered necessary to make the walls strong enough.

Mixing traditional and modern

Much of the vulnerability of present day housing in the Pacific stems from the improper application of new technologies. In particular the use of nails without proper strapping has increased the vulnerability of semi-traditional houses. A house structure can be easily erected with the use of nails, but for sufficient strength it is absolutely necessary to add straps to all connections.

A second mistake that is sometimes made is that corrugated iron sheet roofs are applied without adapting the strength of the building. The uplift forces are much higher, which means that the way the poles are anchored in the ground and all connections up to the roof need to be stronger than is necessary for a house with a leaf roof. The forces on the construction make it difficult to

necessary to give the building sufficient strength to resist horizontal forces.

The following are some details how the required strength can be realised in traditional and semi traditional housing. Two types of details are shown: those based on the use of vines (or cane), and those using steel wire.

Construction details using cane

Principle: the cane can be used for tying around the connection. Alternatively holes can be made in the poles and beams allowing a tighter fixing of the construction. In both cases the cane loops should be tied off with a peg. Sharp edges should be rounded so that the cane ties will not snap.

Anchoring posts to the ground: an anchor beam is connected to the post with five loops of cane. This will prevent uplift.

Tying floor-bearer and post: when a separate bearer is used to construct the floor; it should be tied securely to the post and have the same foundation depth as the post

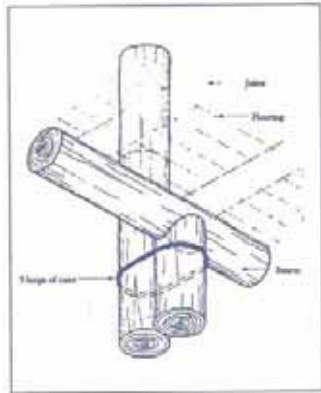

Tie post and floor bearer together for sufficient strength

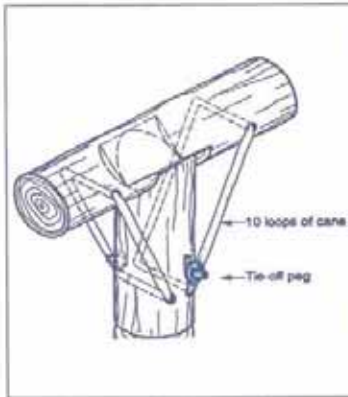

Details for connecting wooden poles with cane

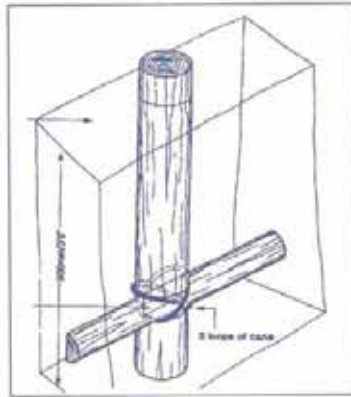

Anchoring posts with an anchor beam

Connecting poles: the strongest way of connecting two poles is by checking the cross beam halfway into the post. This should be tied together by loops of cane

Bracing: the braces that give horizontal strength to the building can be tied together in a similar way.

6. Construction details using steel wire

Steel wire can be used effectively as a strapping method. It is strong enough for application with corrugated iron roofing materials. Roofing nails with washer are used to fix the wires to the construction the wire should be looped around the nail.

Some examples of construction details are shown here, based on the construction methods for a Samoan fale. These details show a characteristic mix of modern and traditional techniques used in an appropriate way.

Foundation: wire used to fix anchor beam.

Rafter to post: one of the most important details in which main elements of the construction are tied together. Holes are drilled into post and rafter to secure their connection.

Details for the roof construction are given in section 4.4.

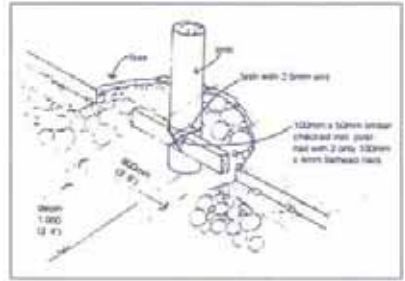

Detail of a post base using wire lashing

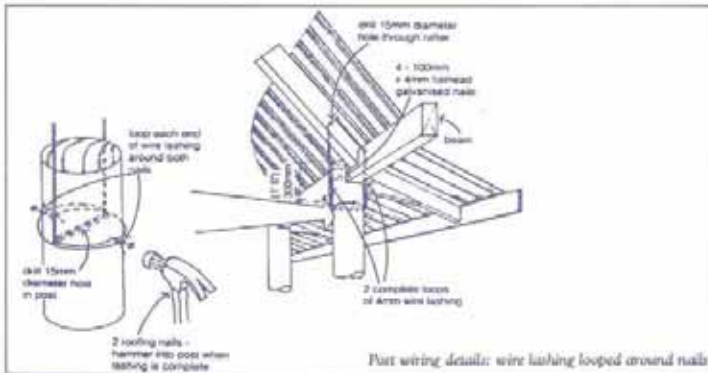

Post wiring details: wire lashing looped around nails

4.3 Concrete block houses

Concrete block houses are becoming increasingly popular in the region. If properly built, a concrete block house can withstand the forces of both earthquakes and windstorms and is a safe form of construction. If improperly built and reinforced, this type of construction is the most dangerous.

Because of the potential risks involved, the construction of a concrete block house requires a slightly more advanced technical approach than the houses described in the previous sections.

The strength of a block house depends on the amount of reinforcement at the corners, the amount of vertical and horizontal reinforcement in the walls, the strength of the foundation, and whether the house is properly balanced. Ideally, reinforcing rods are placed vertically in the corners and walls at no more than 50 cm intervals. At the top of the wall, a ring beam is made of poured concrete. Foundations are cemented and reinforced.

The roof trusses are attached to a horizontal wooden top plate. There are two ways of fastening the top plate. It can either be fastened with bolts embedded in the cement, or by using steel rods protruding out of the ring beam.

The following are the measures to be applied to achieve adequate safety levels:



Concrete Block house in Suva, Fiji

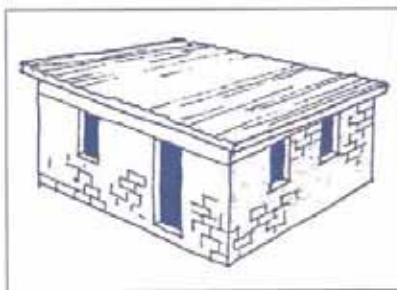

Sketch of a simple concrete block house

Floor plan

The floor plan should be kept simple. A simple rectangular shape is the strongest. The length should be less than 3 times the width of the house. Internal walls that run from one side to the other divide the building in small blocks and make it much stronger. The floor plan (also the internal walls) should preferably be symmetrical.

Mass concrete (with a low percentage of cement) can be used with a mesh wire. The sub base of the floor should be well compacted and levelled in order to prevent later cracks and unequal settlement.

Walls

Proper construction and reinforcement of the walls is of the highest importance for the safety of this type of building. The wall is exposed to pressures from all sides, and reinforcement is necessary to resist these pressures.

Vertical reinforcement: the vertical reinforcement bars should run from the foundation all the way to the ring beam at the top. Alternatively, an overlap of minimum 60 cm. is required. The concrete blocks are placed over the reinforcement bar and the holes are grouted with a cement-sand mix.

Vertical reinforcement is necessary every 1.5 meters, and on both side of openings. In the corners, vertical rods are placed around 60 cm from the corner.

Horizontal reinforcement: horizontal reinforcement bars are placed every second or third row of blocks (max. 60 cm distance). They should also be placed under every opening. Horizontal overlap of steel rods should be 60 cm and the steel rods should be bent at the end, connecting to a vertical reinforcement bar.

Corners: the corner of a concrete wall house acts as the bracing wall, to absorb the horizontal forces on the house. Therefore, the windows should be at least 80 cm from the corners. Horizontal reinforcement should be one bar bent around the corner. They are placed every second layer of blocks. The hooks are bent down, next to the vertical reinforcement bars.

Openings: openings for doors and windows tend to weaken the building. As a general rule, the size of openings should not exceed 50% in any single wall (in particular in earthquake prone countries). Reinforcement bars should be placed on all sides. At the top side of the window, a lintel construction may be necessary, depending on the width of the opening. When a ring beam is located directly above the openings, a separate lintel beam is not necessary.

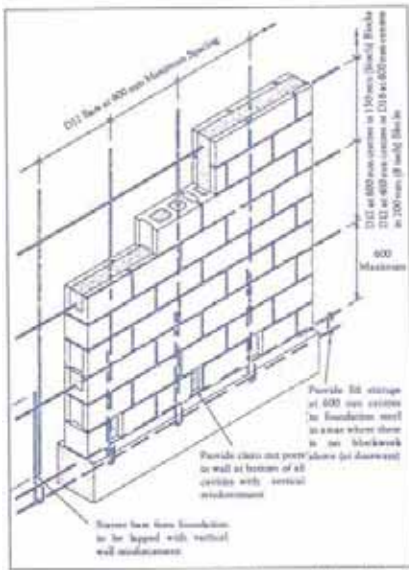

Typical concrete block wall details

Detail of a concrete block bracing wall

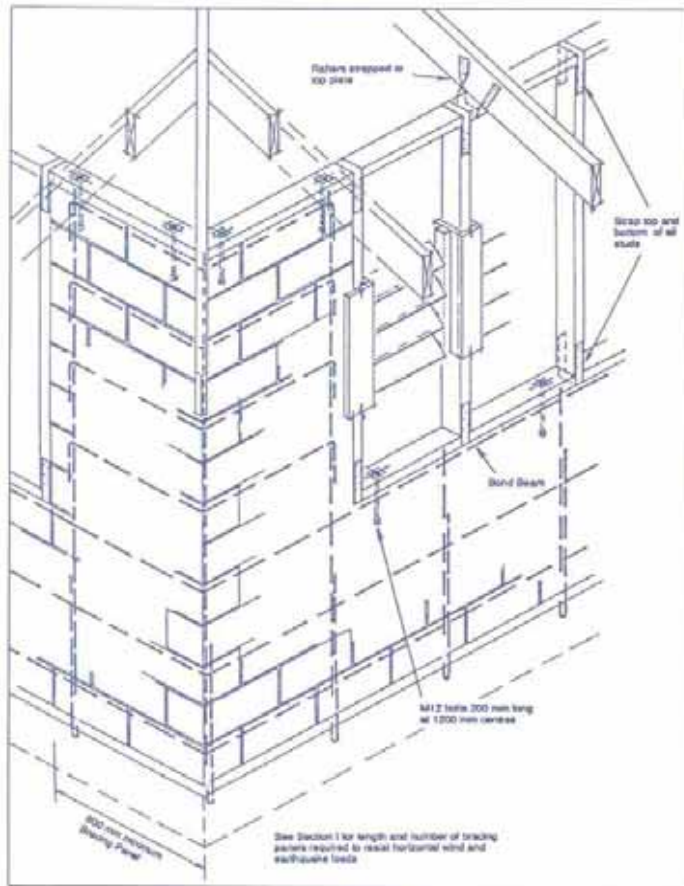

Ring beam

The ring beam is the most important structural element of the concrete block house. It bonds together all walls and gives the construction the strength to resist an earthquake or cyclone. The ring beam is made of poured concrete and forms a strong square to tie together all walls. Horizontal reinforcement bars overlap at least 60 cm. Vertical reinforcement bars can either be bent horizontally to be poured in the ring beam, or stick out to fix the top beam.

8.

Fixing the top plate

The wooden top plate serves as a basis to fix the roof on. It is exposed to uplift wind forces and should be tied securely to the ring beam. This can be done with a bolt that is set in the concrete ring beam or with minimum 30 cm of bent vertical reinforcement (see details).

Roof details are discussed in 4.4

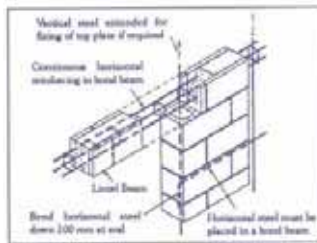

Fixing horizontal ring beam to vertical reinforcement.

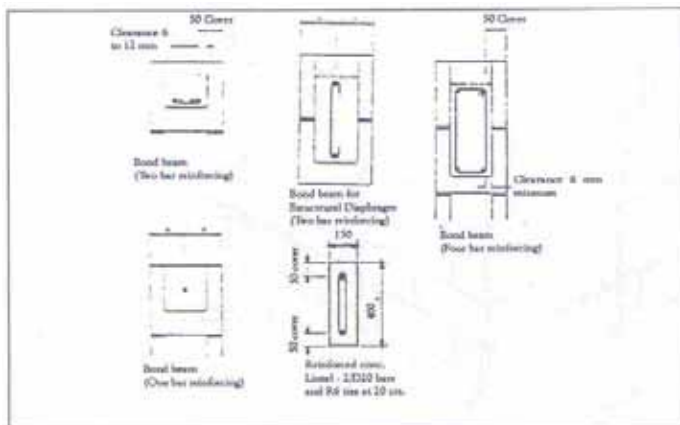

Details of concrete ring beam with reinforcement.

Fixing the top plate using vertical reinforcement bars

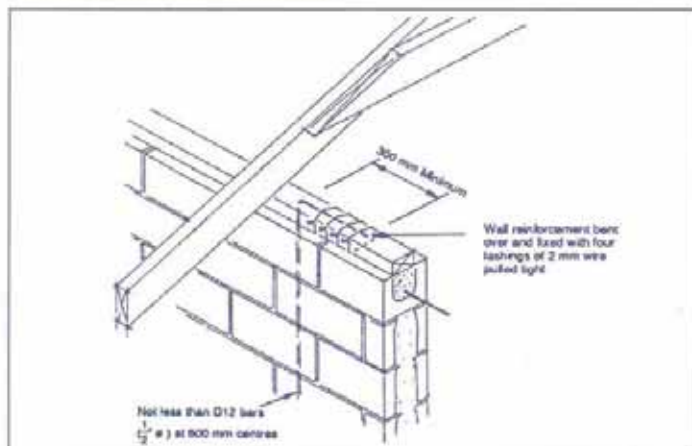

Fixing the top plate with M12 bolts

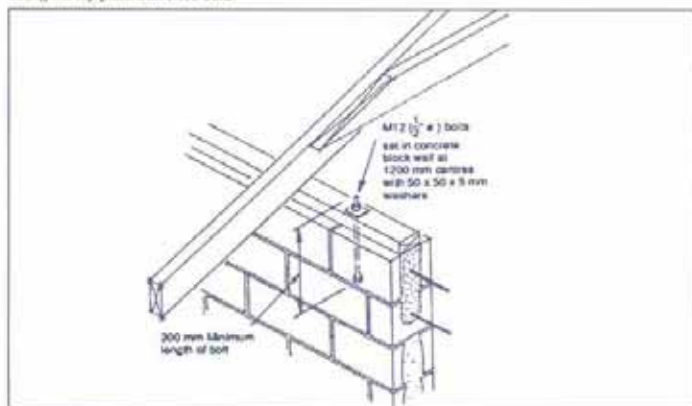

Typical concrete block construction

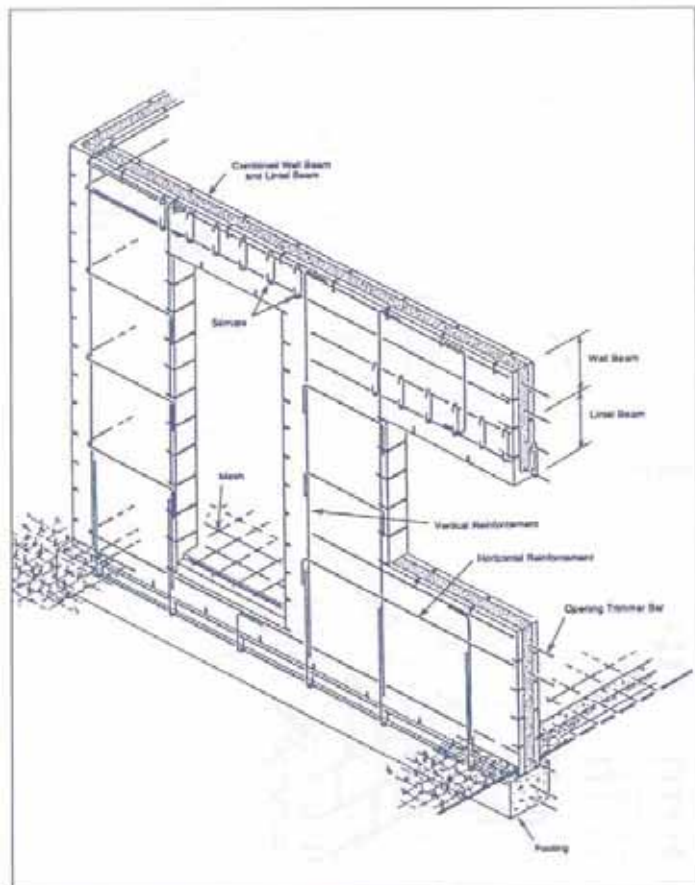

4.4 Safe roof constructions

Roof failure is the main cause of housing damages in tropical cyclones. The main failure mechanisms are:

- wind lifts roofing material off purlins
- wind lifts roofing material and purlins off the roof structure
- failure of the roof structure itself
- roof structure lifts off the posts and beams
- veranda is blown away and tears off the roof

For earthquakes, the roof structure poses less problems. Contrary to many other countries, low cost housing in the Pacific generally uses light roof constructions. When the instructions for cyclone safety are followed, roofs will normally also be able to withstand an earthquake. The descriptions given here therefore focus on withstanding the impact of tropical cyclones.

The two main roofing types applied in the region are corrugated iron and leaf cladding, both on a timber roof structure. For concrete and other heavy types of roofs, formal construction guidelines need to be followed.

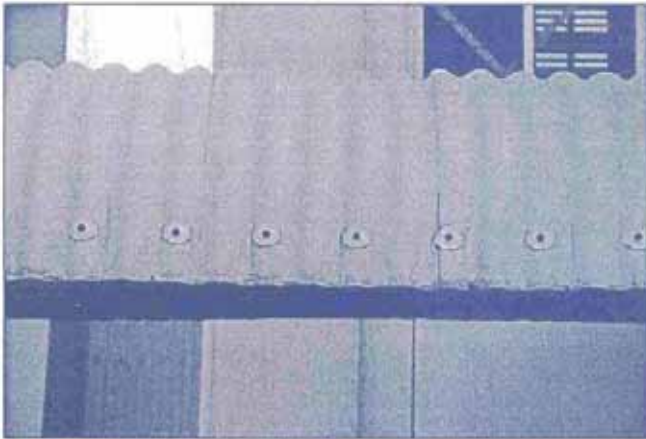

Roof shapes

The strongest shape for a roof is a dome structure. Many of the traditional building forms in the region approach this form. For ease of construction, other roof forms are more and more applied. In Samoa for example, the traditional fale is more and more replaced by a structure with a hipped roof construction.

The following are the main criteria for selecting the appropriate roof construction:

If a pitched roof is to be constructed the hipped roof provides the strongest form.

The hipped roof has two advantages:

- there is less area facing the wind, thus reducing suction
- the hipped roof ends act as bracing so that no separate bracing in the roof is needed

Gable roofs can also be applied, but they require good diagonal bracing and should be steep enough.

A roof pitch should ideally be approximately 30 degrees, or about 1 meter in 3. Wind loads are much more severe when a roof pitch of 5-10 degrees is applied.

Overhangs of more than half a meter should be avoided. It is better to make a separate veranda construction, so that wind trapped under the veranda will not tear off the whole roof.

A round layout is the strongest; rectangular configuration can be used provided that the length to width ratio does not exceed 3:1. L-shaped roofs should be avoided and the parallel walls of all structures should preferably be of equal length and height.

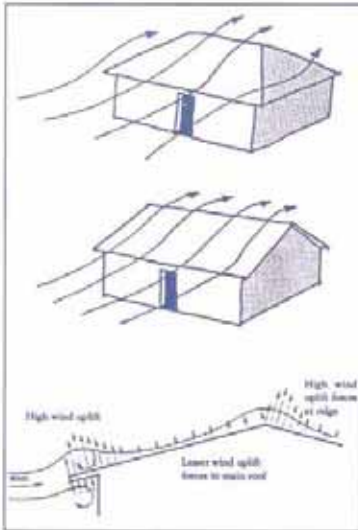

Wind flow and forces on the roof

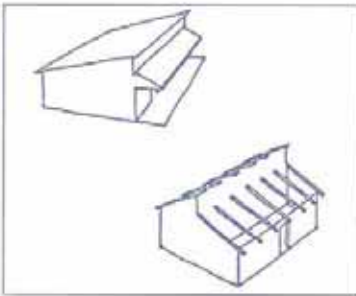

Some vulnerable roof configurations

The choice of the roof type also depends on what is common practice locally. As a general rule it should be noted that the less 'ideal' the roof form is, the more additional measures are needed for sufficient strength.

Main structure

The main structure of the roof consists of two or more roof trusses, braces and purlins. The lay-out of the roof truss depends on its span and on the number of trusses applied. Generally, up to a 6 meter span can be connected with a simple roof truss. A common spacing of roof trusses is between 1 and 3 meters.

All elements of the roof truss should be strapped together for sufficient strength. Two sets of construction details are shown here: one using metal straps and one using wires for strapping.

Strapping the rafter to wall post and top plate

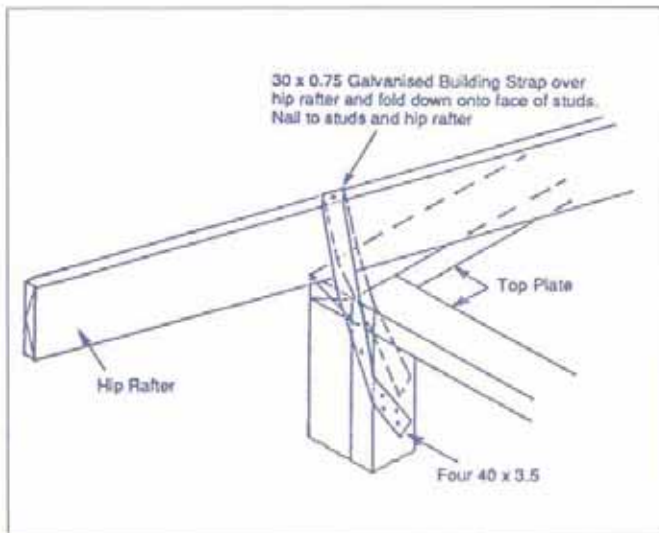

Alternative using a collar tie to fix rafters

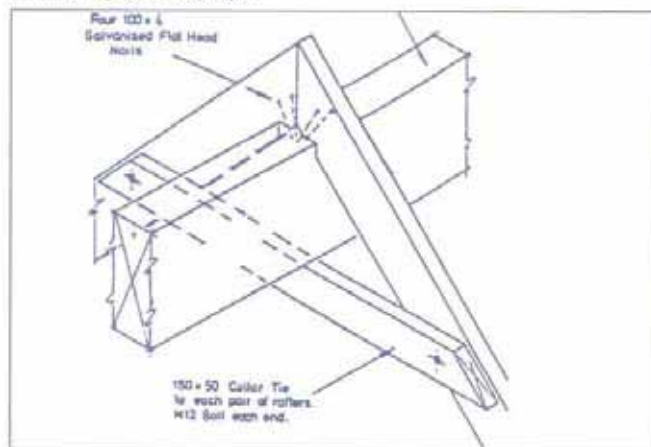

Strapping the rafter to the roof beam

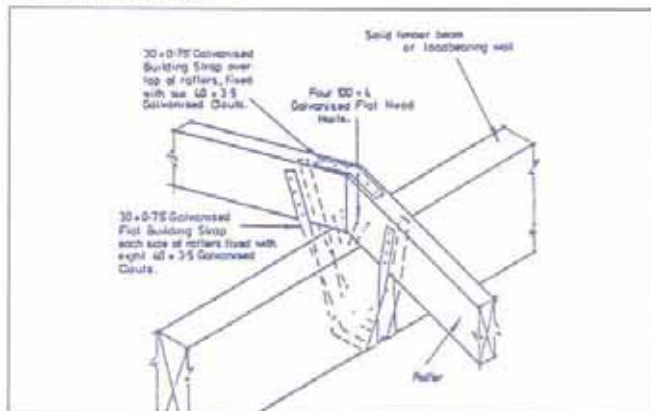

Typical roof truss

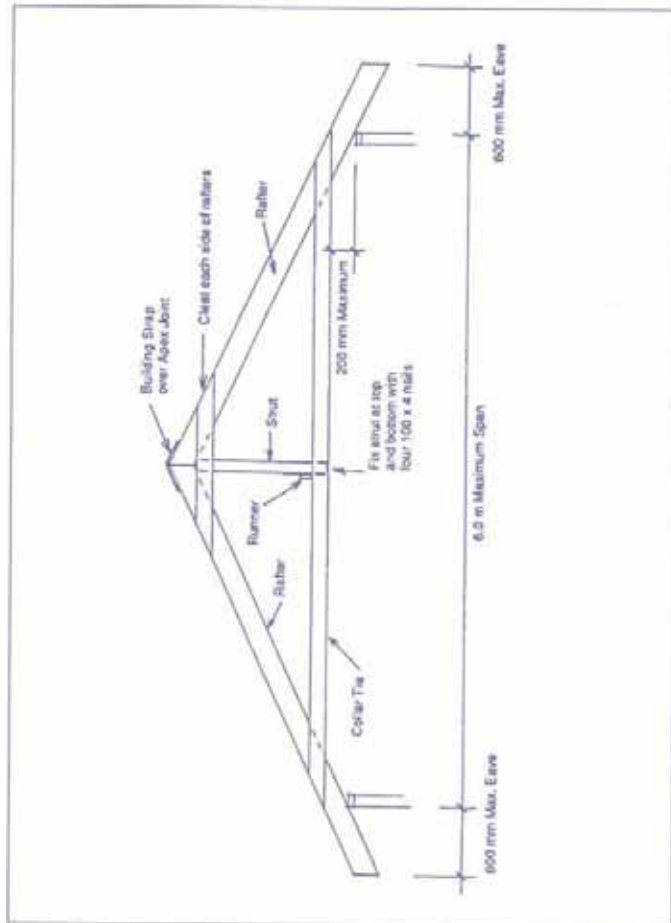

Construction details using wires for strapping

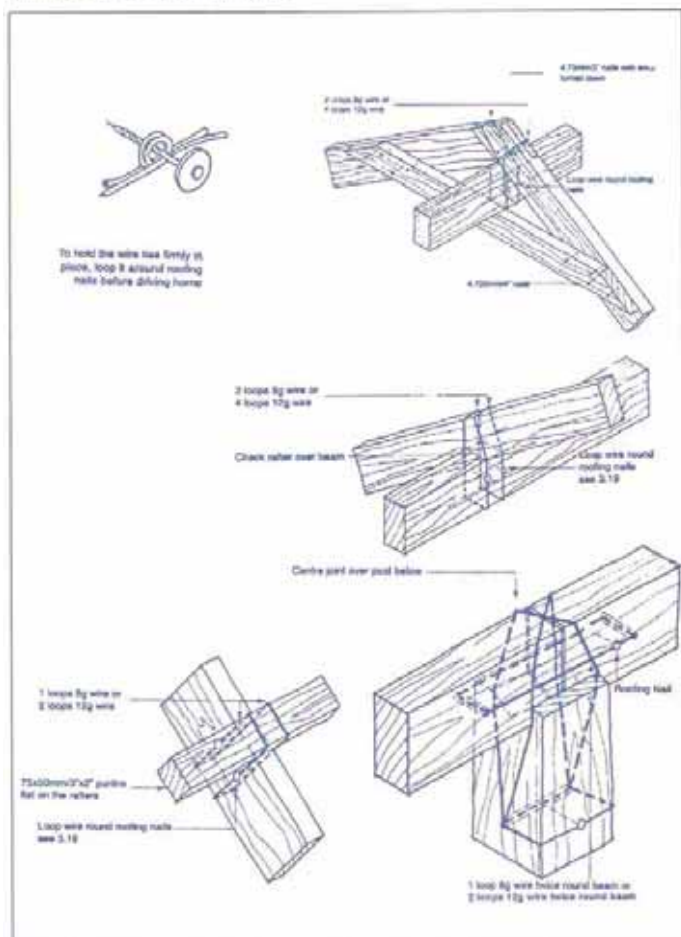

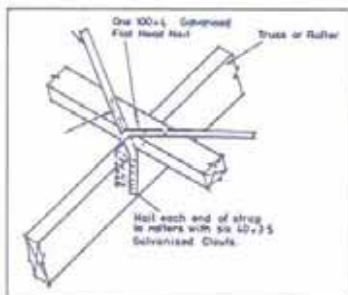

Detail for fixing roof straps

Bracing

The roof trusses should be tied together with braces that run between two or more trusses. These give additional strength to the roof structure and prevent it from being pushed over by sideways forces. When a hipped roof construction is made, forces are lower and the hipped side of the roof is sufficient to resist the force. If necessary metal straps can be fixed cross-wise on top of the purlins to add additional strength.

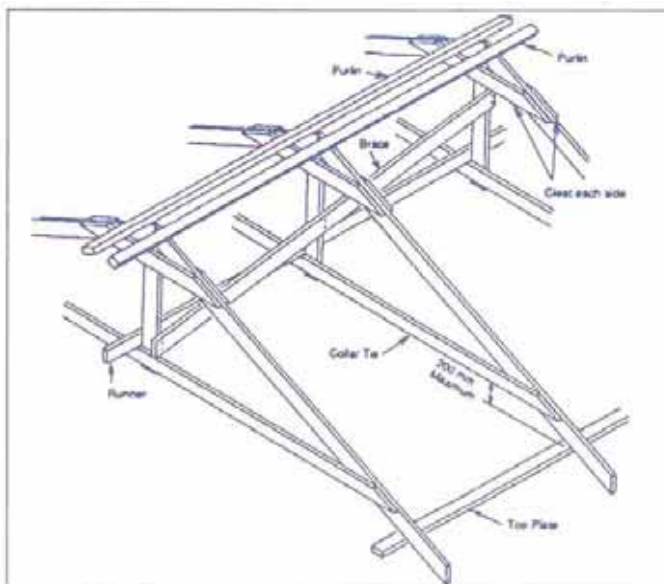

Bracing together the roof trusses

Metal strap diagonal bracing of the roof

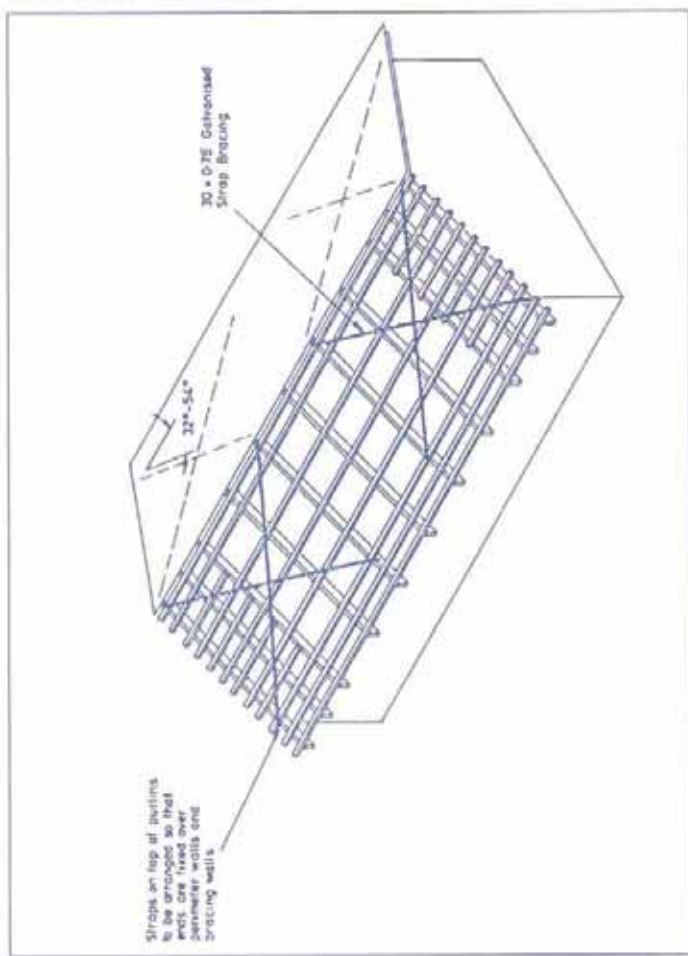

Fixing the roof trusses to the house

Every roof truss has to be securely fixed to the walls. This is one of the most critical points in the construction. The connection has to be strong enough to resist the uplift forces on the roof. The connection has to be strapped or bolted together. By tying together the horizontal ring beam, the post and the roof truss, a stable and strong construction can be realised.

The following devices can be used for proper fixing:

- bolts
- nail plates
- metal straps
- metal wires
- traditional materials (not with corrugated iron!)

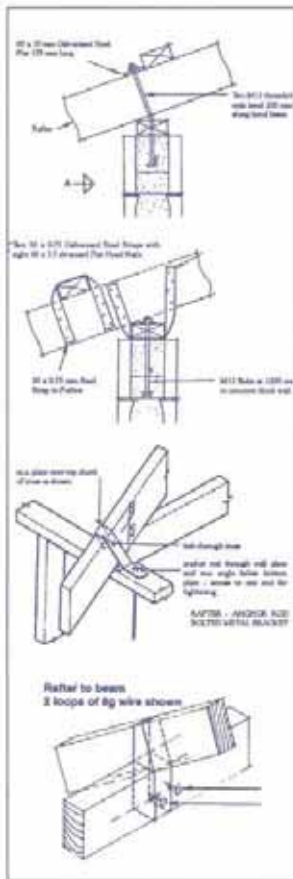

Details for strapping roof trusses to the top plate

Connecting roof cover to the structure:

corrugated iron

The last item to be discussed is how the roof cover is fixed to the roof structure. Corrugated iron sheets are always fixed to horizontal purlins, which in turn are fixed to the roof truss. Each connection is vulnerable to the high winds of a cyclone and proper fixing is needed. The following are the critical points:

Fixing purlins to the roof truss: straps should be used to fix the purlins to the rafters. Again there are various ways of making the connection strong enough. The most common are metal wire and ready made cyclone straps.

Add purlins on the side: the wind forces are much higher at the edges of the roof. To prevent the purlins from being pulled off the structure, additional purlins should be added on the side. As a general rule, the distance between purlins should not exceed 45 cm on the side.

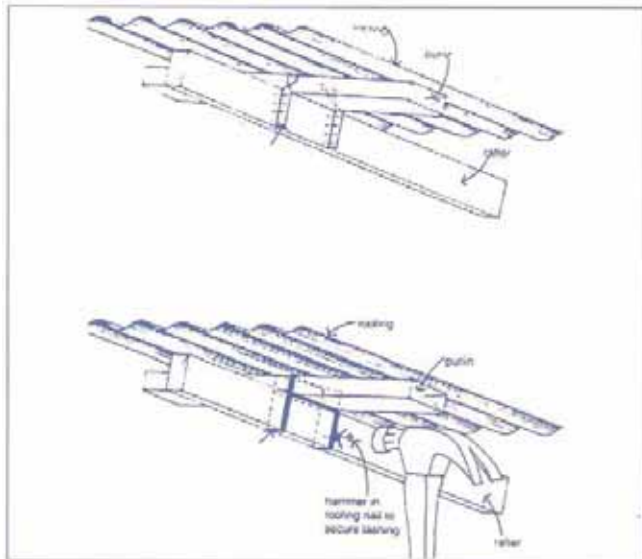

Purlin to rafter connection using steel strips or wire

Fixing the roof sheeting:

to prevent the roof sheeting from breaking away in a cyclone, it should be properly fixed to the purlins. Every second rib must be nailed in all places. Cyclone resistant, spiralling roofing nails should be used with cyclone washer.

Fixing the edge of the roof: the edge of the roof should be properly fixed to prevent the wind from pulling off the roof sheets. Fixing can be done with sawn barge boards.

Nailing pattern and specifications of cyclone proof roofing nails

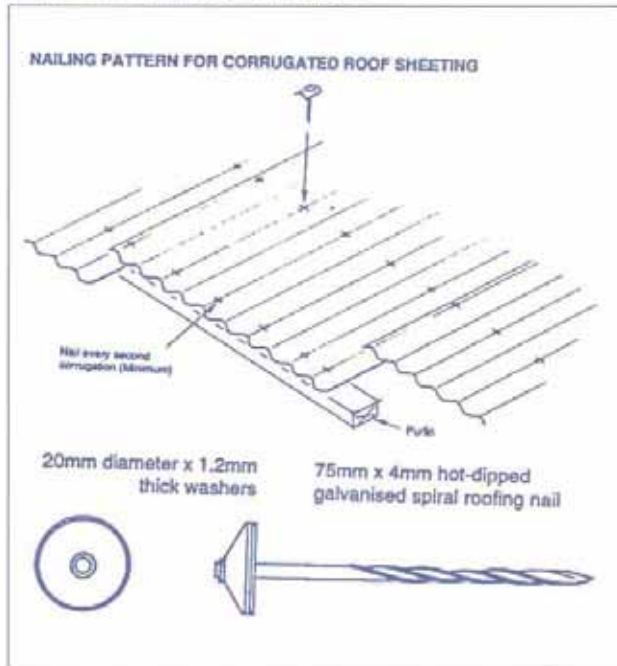

Connecting roof cover to the structure: leaf roofs

Leaf roofs are usually fixed to the roof structure with bamboo roof battles that run down from the top of the roof. Depending on the construction, the bamboo roof battles can be fixed directly to the main structure, or a horizontal support structure is needed. For most of the low cost family housing, no separate structure is needed. The pandanus mats are tied to the bamboo sticks, which in turn are tied to the construction. The span between the purlins is small, often around 10 cm.

On the sides of the roof, moor leaf panels need to be added (closer spacing) to add the necessary strength.

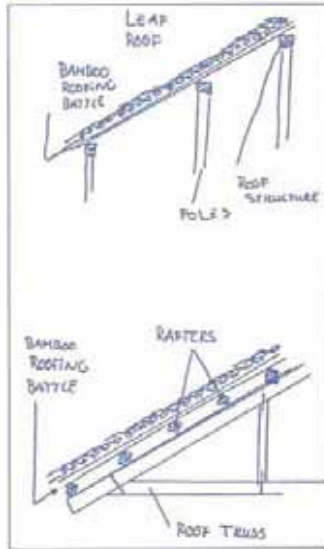

Construction principles for leaf roofs

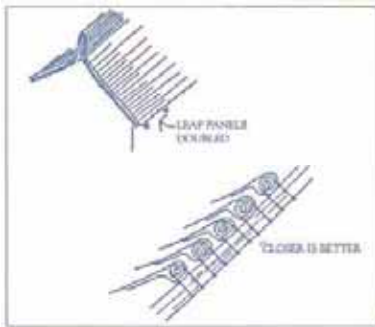

Principles for fixing leaf roof covers

5.Strengthening of existing houses

The previous chapter outlines how to build a new house. Many of the construction details for new housing can also be applied in the successive upgrading of houses. For timber and traditional houses, improvements can be easily implemented over time. Concrete block houses are more difficult to upgrade, since this often requires higher investments.

This chapter briefly outlines the steps that can be taken to upgrade (retrofit) an existing house.

5.1 Making a plan for improvement

First step in the improvement of a house is to identify the weak spots. The principles for safe construction given in chapter 3 indicate which elements should be reviewed. Elements to be checked include:

- strapping of all joints
- spacing and type of roof nails
- diagonal bracing of walls and posts
- strength of foundation piles (against uplift forces)
- connection of the ring beam (in particular in earthquake prone countries)

Key is to look for the weakest spots, because when a hazard hits, that is where it will go wrong. On the basis of the identification of weak spots, an improvement plan can be made. For this, priorities need to be set. In general, the most important elements for improvement are the joints that link the various elements of the construction. They should be securely strapped together in order to form a chain of anchorage from the roof to the ground. Second important element is the bracing, which helps the house to resist horizontal forces.

The improvement programme depends on the means that the household has available. In almost all cases, significant improvements can be made at low cost.

5.2 Progressive upgrading measures

The following is a brief description of measures that are often taken to improve the disaster resistance of the house. For construction details it is referred to the previous chapter.

Roof

Roof failure is a major cause of damage. Improvement of roofs can form a significant contribution to improving the overall strength of the house.

In a low cost approach, the following measures can be implemented:

Roofing nails: increase the number of nails and/or use cyclone resistant nails; focus attention on the eaves of the roof, where the forces highest.

Eaves and overhangs: reduce the size of eaves and overhangs to 40-60 cm; install sideboards to fix the sides of the roof. Seal the eaves of the roof in order to reduce uplift forces of a cyclone.

Strapping of roof elements: all elements of the roof construction should be strapped. Metal straps or wire can be used. Wire is sometimes easier in hard to reach places. The wire should be looped around a nail for sufficient strength.

Strapping to the walls or ring beam: this is one of the most important connections in the building and sufficient strapping is indispensable. Preferably use ready made metal straps here.

Separate veranda construction: when the veranda is made as part of the main roof, it is advisable to make a separate construction for it. It can be connected to the walls or roof, but the construction should be such that, when the veranda fails, the rest of the roof can remain intact.

Bracing: bracing of the roof construction itself will add strength to horizontal forces. When no braces are incorporated now, adding braces should be a priority for gable roofs.

Replacement of roof: when the shape of the roof is very vulnerable to high winds (e.g. because it is not steep enough) it may be advisable to replace the whole roof. This can only be done if funds permit. The preferable new roof construction would be a hipped roof with a pitch of at least 3: 1 (width to height).

Walls

Failure of walls occurs when there is insufficient strength to resist horizontal forces or when the different elements of the walls are not tied together properly. In earthquake prone areas, the ring beam (especially at the top of the walls) is an important feature.

The following are common measures to strengthen the walls of existing houses:

Braces in comers: the shape of the house becomes more coherent (and thus stronger) when diagonal braces are placed in each top corner. Ready made fixtures are normally available for easy installation.

Bracing in walls: strength can be added to resist horizontal forces by putting diagonal braces in each wall (in each corner). The braces should be nailed to each post. Their top end should be in each corner of the building.

Interior walls for bracing: for larger houses (with a length of more than 3 times the width), interior walls should be added for additional strength. These walls should be at least 1.5 m. width over the full height. They should be braced. Interior walls can also be used to add strength to concrete block buildings.

Strapping of connections: as with roof structures, the strapping of connections is a low cost and effective improvement measure. All connections should be strapped, and special attention should be given to wall to roof and wall to floor connections.

Adding shutters: an important measure for protection against cyclones is to add shutters. These Can be simple temporary shutters that can be placed in case of a cyclone.

Adding a ring beam to a concrete block building: it is not easy to add a ring beam to a concrete block house once it is constructed. However, if no ring beam exists, this should be considered a priority.

The roof has to be removed before the beam can be constructed. When vertical reinforcement sticks out of the walls, this can be used to tie the beam to, otherwise it may be necessary to rebuild at least two layers of blocks, in particular in the corners.

Foundations

To improve the strength of foundations, the following can be considered for low cost housing:

Concrete pier foundations: the stone packing of pole foundations can be replaced by casting the poles in concrete of around 40x40 cm. The foundation poles should be conic in shape with the wider end at the bottom.

Anchoring and repacking: a low cost alternative is to add an anchoring beam to the pole and to repack it with rammed rock. This will add considerable strength to prevent the house from being 'pulled' out of the ground.

Increase the number of posts: another way to add strength is to simply add more poles which are properly packed, anchored and strapped to the floor beam.

Braces: when the space between the floor and the ground is more than 1 meter, braces should be added for strength. With a timber foundation, the braces can be nailed to the posts and the floor beams. For houses with concrete pile foundations, reinforced concrete block walls can be added for strength.

Foundation to floor connection: the connection between the foundation and the floor can be improved by adding straps. Also, a ring beam can be added to tie together the floor beams and add overall strength.

Replace deteriorated posts: when posts are deteriorated, they should be replaced by new ones. The whole house should be checked for deteriorated timber, which should then be replaced.

Shutter details

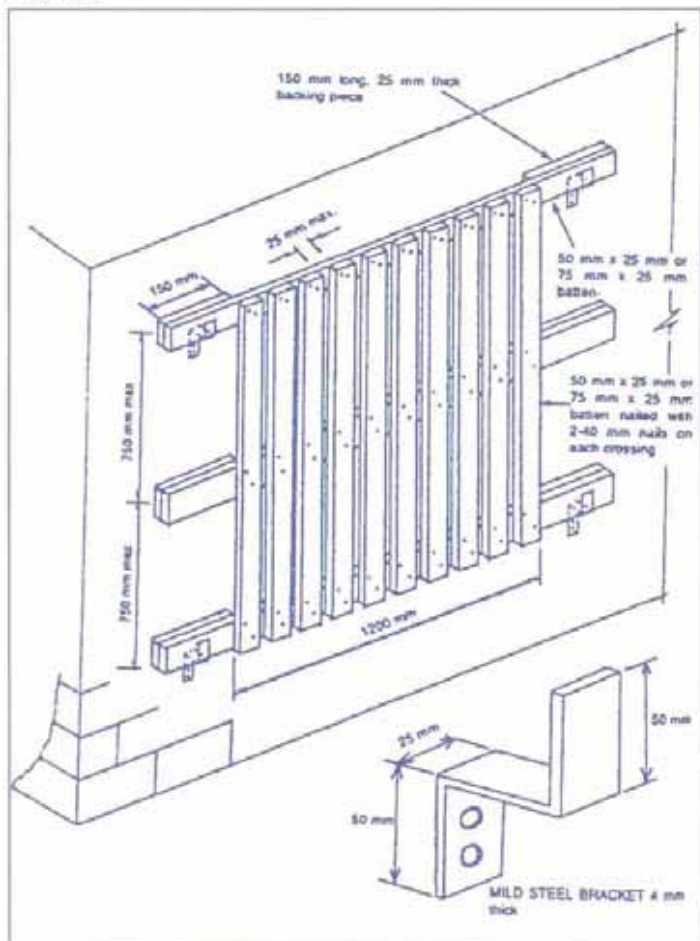

6. Pre-disaster precautions

The following are some precautions that can be taken for cyclones. When you hear a cyclone warning, there are several things you can do to help preserve your house and keep you safe:

Holding down: if you feel your roof is unsafe, place long pieces of timber along each side of the ridge and at eaves, and tie ropes from these down to the foundation stumps to help secure the roof when the wind blows.

Closing off: ensure all window shutters are properly secured and doors shut tightly. Openings between roof and wall should be closed. All objects like plates and bottles should be safely stored and all lamps and other loose objects should be tied down.

Clear away: more loose objects such as canoes, oil drums, loose branches and other items the wind could blow away from your house or into your house.

Recognise risks: cut down rotten trees and branches nearby and fix any loose parts of the house, such as foundation stumps that are rotten or posts that are cracked.

Check connections: check all structural connections in the house and add wire bracing if needed; add additional roofing nails and make other improvements as far as possible.

Laying in supplies: lay in supplies such as clean drinking water; matches, torch, radio, some food and dry clothes. Wrap items that you do not use immediately in a waterproof sheet.

Open louvres on leeward side: when you have louver bladed window, these should be opened at the leeward side; this will reduce the pull force of the wind on the roof.

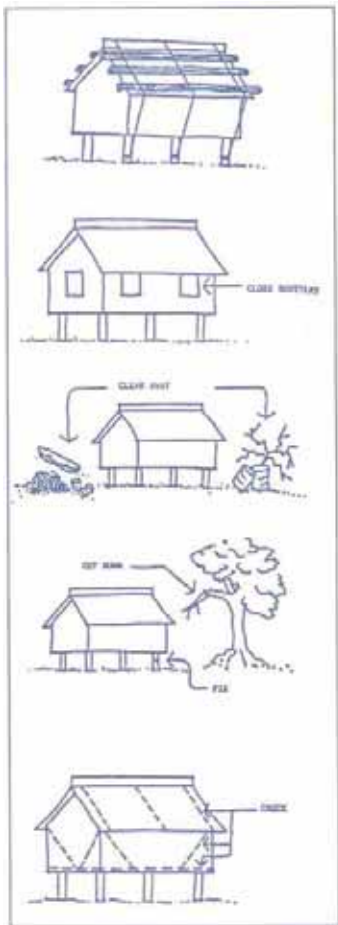

7. Selected designs

On the following pages some basic disaster resistant designs are presented. These designs use many of the features that are described in this compendium. The houses that are shown have been designed, implemented and tested in the region. They can be considered as sufficiently disaster resistant, although not all houses comply to all disaster resistance measures outlined in this guideline.

The selection focuses on low cost timber and concrete block houses, because many of the new houses to be constructed in the region, will be of these types. Brief descriptions are given of each of the designs.



7.1 The Tongan Hurricane Relief house

Over 2000 of these houses were produced after cyclone Isaac devastated much of Tonga in 1982. The houses were prefabricated in Nuku'alofa and assembled on site by the people themselves. In the construction process, people were explained the need for bracing and strapping. The cost per house was around T\$2900, of which T\$700 was paid by the people themselves.

The house is a simple, two room house of 7.2 by 4.8 meters. It is constructed on short timber poles with a wooden floor about 0.5 meters from the ground. The house has a corrugated iron roof. Wall panels and roof trusses of the house are prefabricated. A standard pitch roof of 22.5% was used, and trusses incorporated 300 mm. overhang. The house has galvanised iron braces in all corners and in the roof. Kitchen and sanitary facilities are not included in the house, as these are normally separate in Tongan houses.

The houses have stood up well in consecutive cyclones, and the Ministry of Works is planning on starting a maintenance awareness programme to stimulate some upgrading.





FRONT ELEVATION 1/8" = 1'-0"

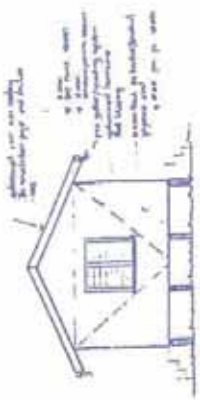

END ELEVATION 1/8" = 1'-0"

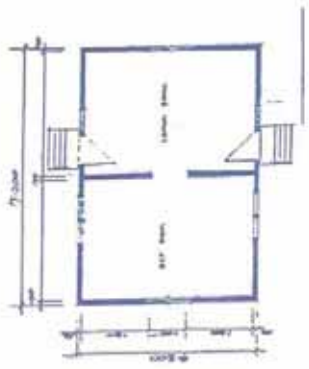

7.2 Cyclone resistant house, Public Works Department Vanuatu

1.

The design for this house was made by the Public Works Department of Vanuatu. Its aim is to stimulate safe construction practices in the country. It is a timber construction with concrete pile foundations and a corrugated iron roof. All timber connection points are strapped and cyclone resistant screws are used to fix the roof. The floor of the house can be made of mass concrete or compacted sand.

The following are some details:

- concrete pile foundations of 40x40 cm, with a depth of 60 cm and 80 cm in the corners
- diagonal braces in all corners and door openings
- material for walls can be adapted to suit local conditions
- cyclone shutters made of plywood
- top ring beam of 200x50 mm.

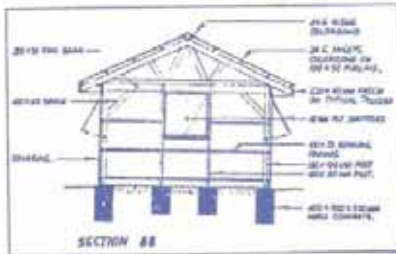

RAISE PAPER TO 24 GAUGE
CORRUGATED

24 G CORRUGATED
ROOF SHEETS 5/8"
WITH 1/4" TYP 17 JOISTS

200 G GALV
TRUSS WITH 1/4" TYP
FRAGS

FRAMING CENTER
24 G CORRUGATED
SHEETS OR CONCRETE
SHEETS OR
LOCAL TIMBER.



FINISHED ELEVATION 2

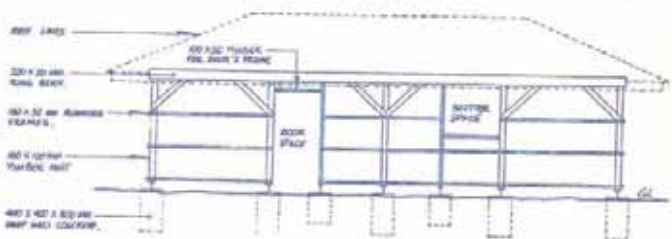

FRAMES ELEVATION 3

RAISE PAPER TO 24 G
CORRUGATED

24 G CORRUGATED 5/8"
WITH 1/4" TYP 17 JOISTS

200 G GALV
TRUSS WITH 1/4" TYP
FRAGS

FRAMING CENTER
24 G CORRUGATED
SHEETS OR CONCRETE
SHEETS OR
LOCAL TIMBER.

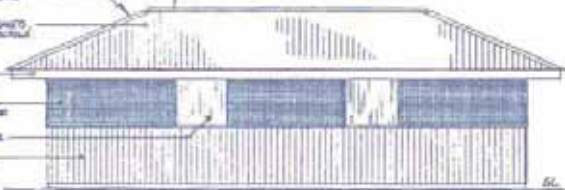

FINISHED ELEVATION 1

7.3 Standard timber house, Regional Development Department, Fiji



As part of its regional development programme, the Government of Fiji provides technical assistance in the form of standard designs. The programme also purchases housing materials and ships these free of charge. There are several standard plans. The plan shown here is only includes the main building sanitary and kitchen are separate.

The plan shows a wooden house of 7.2 by 4.6 meters. The cost of building materials amounts to around F\$4,200 (1997 prices). An evaluation after cyclone Kina in 1993 indicated that this type of house has stood up well. The following are some technical features:

- reinforced concrete posts with a length of 1.20 m. and diameter of 15 cm.
- distance between floor posts 1.80 m.
- wall braces in all corners
- timber roof braces to tie together the roof trusses
- cyclone strapping used on all critical connections
- corrugated iron roof with cyclone resistant roofing nails and washer

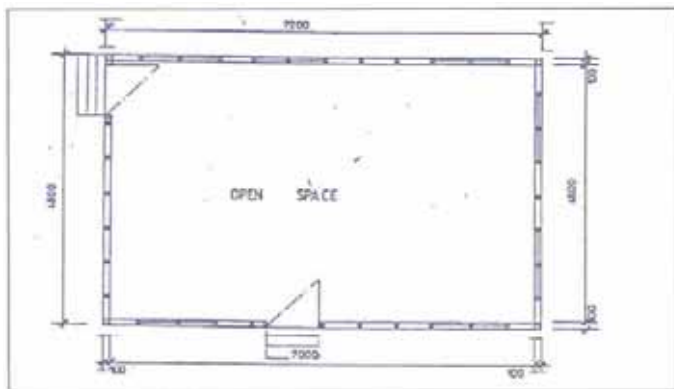

- fascia side boards
- timber top plate to tie together all walls
- ply board walls and pine floor

2.

7.4 Ezi Build Kit Homes, Fiji



Ezi Build is one of the private companies that sell ready made houses in Fiji. These companies sprung up after the Government Housing Programme decided that it would concentrate on providing serviced lots, rather than construct houses. Other companies active in Fiji include Pacific Haus and Falekau. All houses come with cyclone certificate, which means that the engineering standard is enough to be covered by cyclone insurance. This is necessary to obtain bank loans.

The cheapest ready made houses available cost around F\$5,000. This includes assembly, but no painting or interior ceiling. The house shown here is a three bedroom low cost home with shower and toilet. It sells for F\$11,300 including partitioning, ceiling and painting.

Details include the following:

4.

- main house 5 x 9.5 meters
- roof construction annex together with main building
- construction with short concrete poles; span between poles 1.60 m.
- roofing nails according to cyclone specifications
- cyclone strapping on all critical joints
- louvre bladed windows
- floor bearers 100 x 100 mm.
- span of floor joists 450 mm.
- weatherboard external wall sheathing
- veranda can be purchased separately

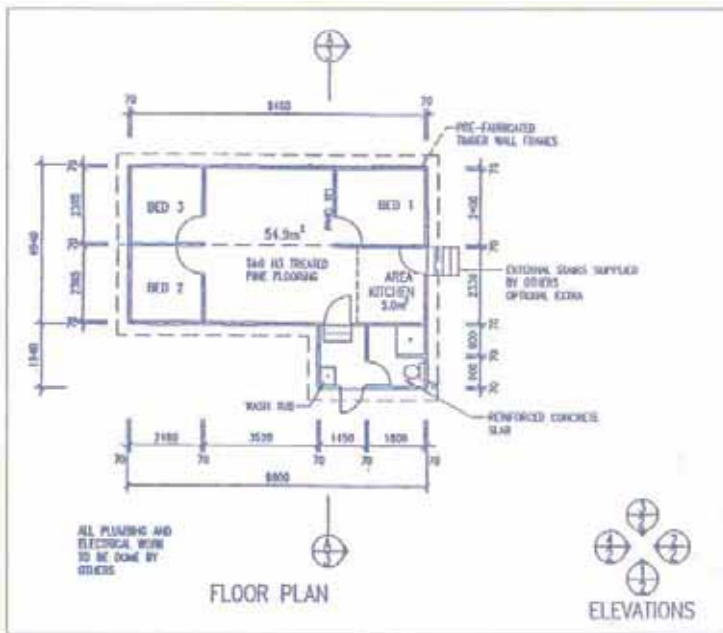

7.5 Standard concrete block house, Regional Development Department, Fiji

This 8x12 meter concrete block house is also part of Fijian regional development programme. It is a three bedroom house with a porch. Total cost of building materials is around F\$17,500. This includes sanitary equipment, septic tank, and all finishing.

the



Specifications include the following:

- reinforced concrete footing
- 100 mm concrete floor with mesh fabric reinforcement
- concrete floor ring band which is cast to the floor
- concrete blocks with vertical reinforcement every 600 mm.
- top ring beam of 400x150 mm. with extra reinforcement in the corners roof trusses that are fixed with nail plates
- distance between purlins 600mm
- roof tied to ring beam with 12 mm. bolts

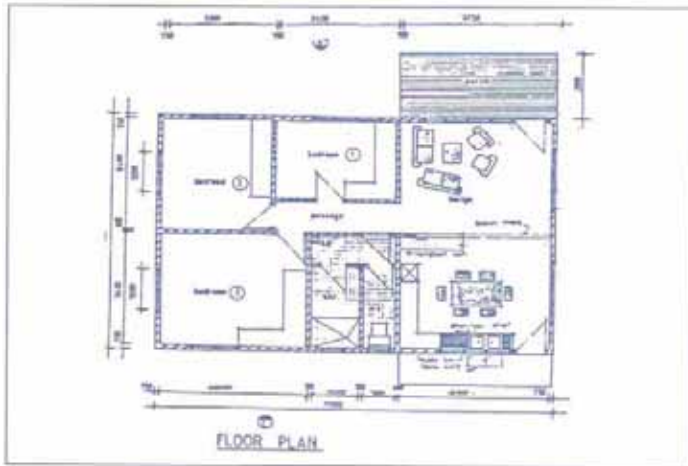

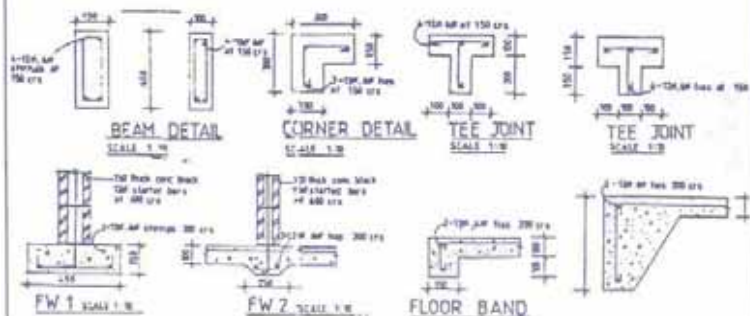
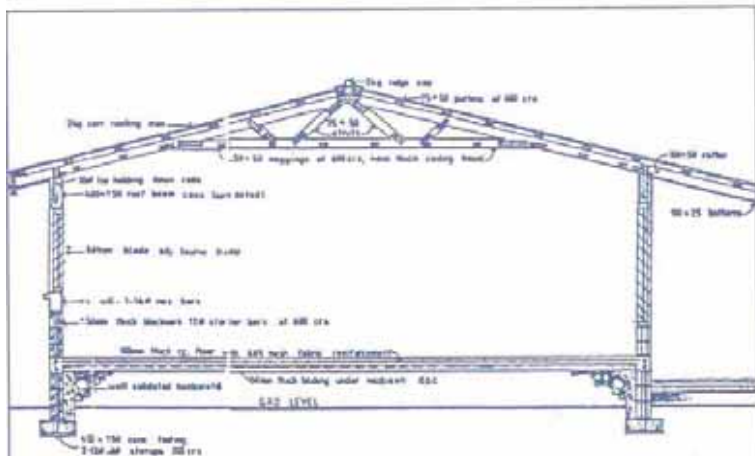

8. Housing improvement programmes

The technical aspects discussed in this compendium only cover a limited segment of housing improvement programmes. Any programme to reduce the vulnerability of housing will include a combination of measures, policies and activities. These have to be selected and combined in accordance with local circumstances. This chapter introduces some building blocks that can be part of an integrated approach to improve the quality of low cost housing.

It is beyond the scope of the compendium to give a full overview of the types of activities that can be carried out. This chapter only serves as a reminder of the variety of elements that may need to be addressed in reducing the vulnerability of low cost housing in Pacific island countries.

Assess vulnerability and risk

Programmes will normally start with an analysis of vulnerabilities of the different housing types and the overall risks to which people are exposed. This does not have to be an in depth technical study, but it should cover the potential hazards as well as the dominant building types.

Analyse current building process

In order to identify the right mix of measures, it is necessary to have a close look at how the building process is now organised. Questions that need to be addressed include who participates in the building process; what skills are available; are all required materials available locally; and how are houses financed.

Review current types of houses

It is also necessary to have a good overview of the current housing types and the construction details that are normally applied. This indicates possible major problems in the existing housing stock and indicates on what elements the building process can focus.

Define an integrated approach

On the basis of the above, the main ingredients of the housing vulnerability reduction programme can be identified. The chosen approach will depend on available funds. It is important to have senior level policy support, as well as support from community organisations for the approach proposed. This will help in the implementation. A budget and work plan should be part of the approach.

Provide public awareness materials

The development of public awareness materials is often a crucial element in the programme. These should help to make people receptive for new ideas by explaining how these can help to improve their safety. The public awareness materials should be made for specific target groups.

Use TV, film, video, radio

Audio-visual training aids are very powerful in introducing and explaining new technologies and measures to be taken for safety. They can be used at all levels. Combinations between pilot activities and audio-visual means can help to spread the knowledge gained in pilot projects.

Train the builders

The people that are most closely involved in the building process can be a major target group for specific technical training. These can be the workers of formal contractors, but also informal contractors or village carpenters. This depends on the nature of the building process and the focus of the programme. One approach can be to train one or more village carpenters who then help to build all houses in their village.

Make manuals and guidelines

Manuals and guidelines can be used to introduce the technical construction principles. This compendium forms a start with a collection of different techniques that are applied throughout the region. It may have to be adapted to suit specific national circumstances or target groups.

Work with pilot projects

One of the most powerful tools in showing how a safe house can be built is by actually building it. Pilot projects are an important part in all housing improvement projects. The pilot can be a new house, or for example the strengthening of a school or church. This will help people to understand what can be done and how it has to be done. The pilot project can also be used as 'practical work' in a training programme, and it can be well documented for use as training or public awareness material.

Provide technical advice

A useful tool can be to provide specific technical advice to individual households on how they can improve their own house to make it more disaster resistant. This tailor made advice helps people to become aware how they can improve their situation within their limited means. An improvement plan can be made with each household to suit its particular circumstances and budget.

Broaden the role of the building inspection

The traditional role of the building inspection is to make sure that buildings are constructed in accordance with building codes. This can be supplemented with a role of the building inspection in providing advice for low cost housing.

Supplement the building codes

Most countries in the region have a building code. This code is mainly applicable to engineered buildings. It is too advanced and often too difficult to understand to be applied in low cost housing. Building codes could be supplemented with simple building regulations and standard construction designs.

Use standard designs

Standard designs which suit local circumstances and have clearly outlined details can greatly assist people to build their house according to safety requirements. It is important that the standard designs are realistic and cost effective.

Help people to reduce costs

Part of the housing improvement programme can be finding ways and means to reduce the cost of building materials. This can for example be done by subsidising (or providing tax exemptions for)



cyclone strapping or cyclone resistant roofing nails. Cost reductions can also be achieved by providing subsidies for transport, so that appropriate materials also become available in isolated locations.

Improve access to funds

An important limitation for people in building quality housing is the limited access to funds. The housing improvement programme could improve this, by establishing agreement with banks so that requirements for loans are reduced. An alternative approach is setting up cooperatives, where successive improvements can be made through a cooperative savings and loans mechanism.

Use certificates in insurance

Only in some countries of the region, insurance brokers request a 'cyclone safety certificate'. Such a certificate can act as a stimulus for building houses according to safety requirements. It could also be used in other countries. To be workable, it is important that standards are not unrealistically high.

Stimulate Maintenance

Housing maintenance programmes can form an important contribution to disaster risk reduction. They can be implemented together with other initiatives or as separate programmes. Key is to assess critical construction elements and demonstrate how these can be strengthened.



Annexes

Annex 1 . List of persons consulted

1. 5th IDNDR Pacific Regional Disaster Management Meeting (Nuku'alofa, Tonga, 1419 September 1996)

Meeting participants

2. Tonga (20-26 September 1996)

Mr. Pilimi 'Aha, Director NOMa and Deputy director, Ministry of Works

Mr. Paula Sunia Bloomfield, Director of Education, Youth, Sports & Culture

Mr. Haniteli '0 Fa'Anunu, Director of Agriculture and Forestry

Mr. Willow Samani, Deputy Director, Ministry of Lands

Mr. Paulo Kautoke, Acting Director, Central Planning Office

Mr. Leveni 'Aha, Chief Architect, Ministry of Works

Mr. Laumeesi MaLolo, Director of Health

Ms. Pamela Lino, Director, Red Cross

Mr. Sunia Takai Makasi, Branch Manager, National Pacific Insurance Ltd

Ms. 'Ana Tupou, MMI Insurance

Mr. Simone Silapelu, President, TANGO

Mr. Sione Taumoepeau, Director of Works, Ministry of Works

3. Solomon Islands (30 September - 5 October 1996)

Mr. Randall Biliki, Director National Disaster Management Office

Mr. Mick Castley, General Manager, and staff, Solomon Islands Plantations Limited (SIPL)

Mr. Robert Zutu, Town Planner Honiara Town Council (including field visit)

Mrs. Judith Siota, General Secretary, Development Service Exchange and Mr. Peter Kakai, Solomon Islands Red Cross Society

Ms. Phyllis Talloikwai, Permanent Secretary for Home Affairs

Mr. Steve Likaveke, Chief Physical Planner, Ministry of Lands and Housing
Mr. Gordon Tusa, Chief Architect Ministry of Works
Mr. Joseph Hasiou, Town Clerk and staff, Honiara Town Council
Mr. George Muir, Managing Director of Fletcher&Kwaimani Joint Venture construction company Mr.
Don Boyke, Managing Director of Pacific Architects
Mr. Geoff Batey, Director of Bain Hogg Solomon Islands Limited, insurance Brokers
Mr. Abraham Banisia , Founder & Director of Solomon Islands Development Trust (SIOT) Mr.
Shadrach Fanega, Assistant Secretary for Central Planning

4. Vanuatu (7 - 10 October 1996)

Mr. Job Esau, Acting Director National Disaster Management Office
Mr. Manaseh Tari, Acting Director Ministry of Works
Mr. Paul Willy, Director National Housing Corporation (includes field visit)
Mr. Harry Tete and staff, Physical Planning Unit, Ministry of Home Affairs
Mr. Gordon Craig, Chief Architect, Ministry of Works
Mr. Bob Loughman and staff, Rural Skills Training Programme
Ms. Karen Preston, Country Director, and Mr. H. Vira, Assistant Director, FSP Vanuatu Mr.
James Toa, National Planning Office
Ms. Rolenas Lolo , Vanuatu National Council of Women
Mr. Lazare Asal, Executive Director, Department of Culture, religion, Women's Affairs and Archives
Mr. Sakaru Tsuchiya and Mr. Charles Kick, UN ESCAp, Pacific Operations Office (EPOC)
Mr. Geoffrey Feast, James Feerie and Partners, Architects
Dr. T. J ayaraman, Senior Project Economist, Asian Development Bank
Ms. Suliana Siwatibau, Community development expert
Ms. Antoinette Coulon and Ms. Elisabeth Muliaki Land Officers, Ministry of Lands Mr.
Stephen Wyatt, Vanuatu Land Use Planning Project

5. Western Samoa (10 - 14 October 1996)

Ms. Georgina Bonin, UNDP Apia

Mr. Cam Wendt, Department of Foreign Affairs

Mr. Poloma Komiti, Prime Minister's Department

Ms. Luagalau Foisaga Eteuati-Shon, Secretary for Women's Affairs

Mr. Galuvao Tanielu, Commissioner of Police

Mr. Bismarck Crawley, GIS/Database Analyst Officer, South Pacific Regional Environment Programme (SPREP)

Taulealeausumai Dr. Eti Enosa, Director-General of Health

Mr. Faatoia Malele, Acting Director Apia Observatory

Ms. Lusia Sefo-Leau, Assistance Financial Secretary Planning and Policy

Mr. Mila Posini, Assistant Director of Public Works, Building Division Mr.

Maka Sapolu, Director Red Cross

6. Fiji (27 September and 15 - 19 October)

Mr. Poasa Ravea, Deputy Secretary for Regional Development

Mr. Akapusi Tuifagalele, Senior Administrative Officer NDMO

Mr. Toka, Acting Commissioner Western Division,

Fiji Red Cross, Fiji Council of Social Services (FCOSS), and the Rural Housing Unit of the Department of Regional Development

Mr. Somsey Norindt; UNDP Resident Representative

Ms. Margareth Chung, Population and Development expert, UNDP

Mr. Jeff Liew, CTA Equitable and Sustainable Human Development Programme (ESHDP; telephone discussion)

Fiji Housing Authority, Home Finance Fiji and National Rental Board, Mr. Ratu Viliame Volavola, Mr.

Arne Racule, Mr. Gregory Moore, Ms. Marica Rokovada

Mr. John Scott, Director General Fiji Red Cross

Mr. Isoa Korovulevule, Coordinator SPACHEE, South Pacific Alliance for Conservation, Human Ecology and the Environment

Mr. Sevenaia Dacaica, Chief Planner; Department of Town and Country Planning

Mr. John Bola, regional specialist on housing and building

Mr. Joe Chung, Head of South Pacific Disaster Reduction Programme (SPDRP) Mr.

Ian Rectol; Disaster management advise!; SPDRP

Ms. Joanne Burke, Training Adviser SPDRP

Mr. Atu Kaloumaira, Disaster Mitigation Adviser SPDRP

Ms. Angelika Planitz, Technical Adviser SPDRP

Annex 2 Literature

- Aynsley, Lapish and Boyle, Stronger village houses in Solomon Islands, Uniservices, Auckland, 1995
- Blair and Spangle, Seismic safety and land use planning, selected examples from California, US Government, Washington, 1979
- Boen, Teddy, Detailer's manual for small buildings in seismic areas, IAEE, not dated
- Boen, Teddy, Manual for repair, restoration, and strengthening of non-engineered buildings damaged by earthquakes, Jakarta, 1992
- Boyle, Charles, Disaster resistant housing, a handbook of guidelines, AOORO, Canberra, not dated
- Coifflet; Christian, Traditional architecture in Vanuatu, USp, Suva, 1988
- Department of Rural Development and rural housing, Standard wooden frame dwelling house, Government of Fiji, not dated
- Ezibuild, Ezi Build kit homes, standards designs and details, Suva, 1996
- Falekau, Standard design and specifications, Suva, 1996
- Government of Western Samoa, Fale Mautu, Stronger buildings, Apia, 1994
- Government of Western Samoa, Home building manual for Western Samoa, Apia, 1992
- Government of Western Samoa, National Building Code for Western Samoa, Apia, 1992
- Hamnett, Michael and Hurrell, Soane, Reducing the vulnerability to natural disasters: a prototype program developed in the Solomon Islands, PLOp, Honolulu, 1984
- IAEE, Basic concepts of seismic codes, Vol. 1, IAEE, Tokyo, 1980
- Intertect, Improvement of low-cost housing in Fiji to withstand hurricanes and earthquakes, USAID/OFOA, Washington, 1982
- Intertect, Improvement of low-cost housing in the Cook Islands to withstand tropical cyclones, USAID/OFOA, Washington, 1982
- Intertect, Improvement of low-cost housing in Tonga to withstand hurricanes and earthquakes, USAID/OFOA, Washington, 1982
- Intertect, Improvement of low-cost housing in Tuvalu to withstand hurricanes, USAID/OFOA, Washington, 1982

- Intertect, Minimum standards for cyclone resistant housing using traditional materials, PIOP, Honolulu, 1981
- James Ferrie and Partners, Structural details, standard concrete block wall home, Port Vila, 1996
- Macks, K.J., The A.B.C. of cyclone rehabilitation, UNESCO, Paris, 1996
- Ministry of Fijian Affairs and Rural Development, Standard 24'x18'timber frame flat roof building, Government of Fiji, Suva, 1992
- Ministry of Regional Development, Standard concrete block house, Suva, not dated
- PADCO Inc., Disaster assistance manual for transition housing, USAID/OFDA, Washington, 1981
- PAHO, Disaster mitigation guidelines for hospitals and other health care facilities in the Caribbean, Washington, 1992
- Public Works Department Tonga, The Tongan hurricane relief house for cyclone Isaac, Nuku'alofa, 1982
- Public Works Department Vanuatu, Standard design for a cyclone resistant house, Government of Vanuatu, Port Vila, 1994
- Public Works Department, Strengthening village fales for strong winds, Government of Western Samoa, Apia, 1994
- Sababu Kaitilla (ed.), Disaster Housing, proceedings of the South Pacific Regional Conference in Lae, June 1994, Kirsten Press, Madang, 1995
- Thompson, Paul, A model programme for reducing housing vulnerability, PIOP / Intertect, Hawaii, 1983
- UN ORO, Mitigating natural disasters, phenomena, effects and options, United Nations, New York, 1991 (UNDRO/MND/1990 Manual)

Annex 3: References per section

1. Introduction

- Coiffier; Christian, Traditional architecture in Vanuatu, USP, Suva, 1988

2. Problems: what goes wrong

2.1 Cyclones

- Aynsley, Lapish and Boyle, Stronger village houses in Solomon Islands, Uniservices, Auckland, 1995
- Boyle, Charles, Disaster resistant housing, a handbook of guidelines, AODRO, Canberra, not dated
- Government of Western Samoa, Fale Mautu, Stronger buildings, Apia, 1994
- Macks, K.J., The A.B.C. of cyclone rehabilitation, UNESCO, Paris, 1996
- UNDRO, Mitigating natural disasters, phenomena, effects and options, United Nations, New York, 1991 (UNDRO/MND/1990 Manual)

2.2 Earthquakes

- Boen, Teddy, Detailer's manual for small buildings in seismic areas, IAEE, not dated
- IAEE, Basic concepts of seismic codes, Vol. 1, IAEE, Tokyo, 1980
- Intertect, Improvement of low-cost housing in Fiji to withstand hurricanes and earthquakes, USAID/OFDA, Washington, 1982
- Sababu Kaitilla (ed.) , Disaster Housing, proceedings of the South Pacific Regional Conference in Lae, June 1994, Kirsten Press, Madang, 1995
- UNDRO, Mitigating natural disasters, phenomena, effects and options, United Nations, New York, 1991 (UNDRO/MND/1990 Manual)

3. Principles for safe construction

3.1 Cyclones

- Boyle, Charles, Disaster resistant construction for traditional bush houses, AODRO, Canberra, not dated

3.2 Earthquakes

- Boen, Teddy, Detailer's manual for small buildings in seismic areas, IAEE, not dated
- IAEE, Basic concepts of seismic codes, Vol. 1, IAEE, Tokyo, 1980
- Sababu Kaitilla (ed.), Disaster Housing, proceedings of the South Pacific Regional Conference in Lae, June 1994, Kirsten Press, Madang, 1995

4. Construction of new houses

4.1 Wood frame houses

- Aynsley, Lapish and Boyle, Stronger village houses in Solomon Islands, Uniservices, Auckland, 1995
- Government of Western Samoa, Fale Mautu, Stronger buildings, Apia, 1994
- Government of Western Samoa, Home building manual for Western Samoa, Apia, 1992
- Hamnett, Michael and Hurrell, Soane, Reducing the vulnerability to natural disasters: a proto-type program developed in the Solomon Islands, PIDp, Honolulu, 1984
- Intertect, Improvement of low-cost housing in Fiji to withstand hurricanes and earthquakes, USAID/OFDA, Washington, 1982
- Macks, K.J., The A.B.C. of cyclone rehabilitation, UNESCO, Paris, 1996
- Public Works Department, Strengthening village fales for strong winds, Government of Western Samoa, Apia, 1994

4.2 Traditional and semi-traditional houses

- Aynsley, Lapish and Boyle, Stronger village houses in Solomon Islands, Uniservices, Auckland, 1995
- Boyle, Charles, Disaster resistant construction for traditional bush houses, AOOO, Canberra, not dated
- Coiffier, Christian, Traditional architecture in Vanuatu, USP, Suva, 1988
- Government of Western Samoa, Fale Mautu, Stronger buildings, Apia, 1994
- Intertect, Improvement of low-cost housing in Fiji to withstand hurricanes and earthquakes, USAID/OFDA, Washington, 1982

- Intertect, Improvement of low-cost housing in Tuvalu to withstand hurricanes, USAID/OFDA, Washington, 1982
- Public Works Department, Strengthening village fales for strong winds, Government of Western Samoa, Apia, 1994

4.3 Concrete block houses

- Boen, Teddy, Detailer's manual for small buildings in seismic areas, IAEE, not dated
- Government of Western Samoa, Home building manual for Western Samoa, Apia, 1992
- James Ferrie and Partners, Structural details, standard concrete block wall home, Port Vila, 1996
- Sababu Kaitilla (ed.) , Disaster Housing, proceedings of the South Pacific Regional Conference in Lae, June 1994, Kirsten Press, Madang, 1995

4.4 Safe roof constructions

- Aynsley, Lapish and Boyle, Stronger village houses in Solomon Islands, Uniservices, Auckland, 1995
- Boyle, Charles, Disaster resistant construction for traditional bush houses, AODRO, Canberra, not dated
- Government of Western Samoa, Home building manual for Western Samoa, Apia, 1992
- Intertect, Improvement of low-cost housing in Fiji to withstand hurricanes and earthquakes, USAID/OFDA, Washington, 1982
- PADCO Inc., Disaster assistance manual for transition housing, USAID/OFDA, Washington, 1981
- Public Works Department, Strengthening village fales for strong winds, Government of Western Samoa, Apia, 1994

5. Strengthening existing houses

- Boen, Teddy, Manual for repair; restoration, and strengthening of non-engineered buildings damaged by earthquakes, Jakarta, 1992
- Boyle, Charles, Disaster resistant construction for traditional bush houses, AODRO, Canberra, not dated
- Government of Western Samoa, Fale Mautu, Stronger buildings, Apia, 1994

- Hamnett, Michael and Hurrell, Soane, Reducing the vulnerability to natural disasters: a proto-type program developed in the Solomon Islands, PLOp, Honolulu, 1984
- Intereact, Improvement of low-cost housing in Fiji to withstand hurricanes and earthquakes, USAIO/OFDA, Washington, 1982
- UNDRO, Mitigating natural disasters, phenomena, effects and options, United Nations, New York, 1991 (UNDRO/MND/1990 Manual)

6. Pre-disaster precautions

- Boyle, Charles, Disaster resistant construction for traditional bush houses, AODRO, Canberra, not dated
- Hamnett, Michael and Hurrell, Soane, Reducing the vulnerability to natural disasters: a proto-type program developed in the Solomon Islands, PLOp, Honolulu, 1984

7. Selected designs

- Department of Rural Development and rural housing, Standard wooden frame dwelling house, Government of Fiji, not dated
- Ezibuild, Ezi Build kit homes, standards designs and details, Suva, 1996
- Falekau, Standard design and specifications, Suva, 1996
- James Ferrie and Partners, Structural details, standard concrete block wall home, Port Vila, 1996
- Ministry of Regional Development, Fiji, Standard concrete block house, Suva, not dated
- Public Works Department Tonga, The Tongan hurricane relief house for cyclone Isaac, Nuku'alofa, 1982
- Public Works Department Vanuatu, Standard design for a cyclone resistant house, Government of Vanuatu, Port Vila, 1994

8. Housing improvement programmes

- Hamnett, Michael and Hurrell, Soane, Reducing the vulnerability to natural disasters: a proto-type program developed in the Solomon Islands, PLOp, Honolulu, 1984
- Macks, K.J., The A.B.C. of cyclone rehabilitation, UNESCO, Paris, 1996

- Sababu Kaitilla (ed.) , Disaster Housing, proceedings of the South Pacific Regional Conference in Lae, June 1994, Kirsten Press, Madang, 1995
- UNDRO, Mitigating natural disasters, phenomena, effects and options, United Nations, New York, 1991 (UNDRO/MND/1990 Manual)

Annex 4

Abbreviations

NGO	Non Governmental Organisation
DESA	UN Department for Economic and Social Affairs
DHA	UN Department of Humanitarian Affairs
DHA-SPPO	DHA South Pacific Programme Office
IDNDR	International Decade for Natural Disaster Reduction
NLTB	Native Land Trust Board
PIC	Pacific Island Countries
PIDP	Pacific Islands Development Program
PNG	Papua New Guinea
SPDRP	South Pacific Disaster Reduction Programme
UN	United Nations
UNDHA	UN Department of Humanitarian Affairs (formerly UNDRO)
UNDP	UN Development Programme
USP	University of the South Pacific
WMO	World Meteorological Organisation