

LOW - COST HOUSING FOR DEVELOPING COUNTRIES:

AN ANALYSIS OF THE DESIGN PROCESS

by

Lawrence Miladinovich Shoup

Thesis submitted to the Faculty of the
Virginia Polytechnic Institute and State University
in partial fulfillment of the requirements for the degree of

MASTER OF ARCHITECTURE

APPROVED:

~~Chairman: Frederick Kringold~~

~~Gregory Hunt~~

~~Lawrence Birch~~

September 1987

Alexandria, Virginia

CONTENTS

| | |
|--|------|
| INTRODUCTION..... | iv |
| Causes for Concern..... | iv |
| Source of Thesis Topic..... | v |
| Format..... | vi |
| Architectural Relevance | vi |
| Charts and Diagrams..... | viii |
| | |
| CHAPTER 1: DESIGN CONSTRAINTS FOR LOW - COST HOUSING IN DEVELOPING COUNTRIES..... | 1 |
| Cultural Constraints..... | 1 |
| Economic Constraints..... | 14 |
| Technical Constraints..... | 25 |
| Social Constraints..... | 38 |
| Political Constraints..... | 45 |
| Environmental Constraints..... | 49 |
| Aesthetic Constraints..... | 53 |
| Charts..... | 55 |
| | |
| CHAPTER 2: SUMMARY OF DESIGN PARAMETERS FOR DEVELOPING COUNTRIES..... | 61 |
| Charts..... | 68 |

| | | |
|-------------------|---|-----|
| CHAPTER 3: | HOUSING DESIGN FOR DEVELOPING COUNTRIES: NEW ARCHITECTURAL ROLES, NEW DESIGN APPROACHES & NEW DESIGN PROCESS..... | 71 |
| | New Roles..... | 72 |
| | New Approaches..... | 75 |
| | New Process..... | 93 |
| | Charts..... | 110 |
| CHAPTER 4: | A CASE STUDY OF THE DOMINICAN REPUBLIC: COUNTRY & HOUSING CHARACTERISTICS..... | 114 |
| | Country..... | 114 |
| | Architectural Influences..... | 118 |
| | Housing Data..... | 122 |
| | Charts..... | 130 |
| CHAPTER 5: | DOMINICAN LOW-COST HOUSING SEMINAR: POSSIBLE LOW-COST HOUSING SOLUTIONS FOR THE DOMINICAN REPUBLIC..... | 143 |
| | Low-Cost Housing Development Proposal: Title: Low-Cost Housing in the Informal Sector..... | 146 |
| | Low-Cost Housing Unit Design by Colombian Architect Santiago Moreno..... | 152 |
| | Low-Cost Construction Material for Roofing: Corrugated Fiber Cement Roofing Tiles..... | 161 |
| BIBLIOGRAPHY..... | | 165 |
| GLOSSARY..... | | 172 |
| VITA..... | | 181 |
| ABSTRACT..... | | |

INTRODUCTION

Causes for Concern

In relation to the topic of this thesis, the question arises why architects of the United States and other fully developed countries should be concerned about the housing shortages in poorer, developing nations - or low-cost housing at all. Charles Correa, a noted architect in the field of development, poses the question of the architect's "relevance" towards those inhabitants of developing nations who lack adequate shelter in the context of the city of Bombay, India :

"There are half a dozen cities of over 10 million inhabitants each, most of them in the richer countries. By the year 2000 A.D., there will be almost 50 cities of over 15 million - of which 40 will be in the Third World. One of them will be Bombay.

Today the city has 8 million people. As recently as 1940, the number was 1.2 million. This scale of growth generates enormous pressures - and perplexing new issues regarding the architect and the political parameters which define his tasks. For in India, as in most Third World countries, he is involved, almost exclusively with a very special clientele - the upper 10% of the population. These are people who commission the office buildings, apartments, factories and houses, that make up the bulk of his practice. The situation is not of the architect's making; it merely reflects the skewed income profile in society itself.

Ironically enough, of course, it is the remaining 90% whose needs are the most desperate. Today in Bombay, almost 3 million people live on pavements and in illegal squatter colonies. Is the architect, with his highly specialized skills, of any relevance to them? "

Pg. 447, "Urban Strategies from the Third World", Charles Correa, HABITAT INTL., Vol. 5, No. 3/4, Ed. O.H. Koenigsberger & S.Groak, Pergamon Press, N.Y.C., 1981

(Figure 1: Chart showing the world's fifteen largest cities in developed and developing countries: 1950, 1980 & 2000)

There are no brief answers to these questions. However, the impact of the homeless and the lack of adequate low-cost shelter is currently being felt in American urban areas, proving that developed countries are not exempt from the problems of the developing world and creating a "relevance" between American architects and the poorly sheltered inhabitants of developing countries. As the world population grows and global concerns become more integrated this "relevance" between architects and low-cost housing will also increase.

Source of Thesis Topic

In February of 1985 my interest in global housing shortages, in particular those related to nonindustrial developing nations, led me to attend a conference in Santo Domingo in the Dominican Republic based on the topic of "Low-Cost Housing for the Informal Sector". At the conference, the main concern of the participants was the problem of providing affordable housing alternatives to those Dominicans without adequate shelter. This concern for providing an actual design solution for housing problems in developing nations formed the initial basis of the thesis. The original intention of the study was to provide a low-cost housing solution that was applicable in the Dominican

Republic. However, as the research progressed, it became evident that the design process warranted closer examination than any possible solution. As a result the thesis became a study of the design process itself.

The conclusions derived in this thesis must be considered the result of my particular experience in the field of development studies, and could have evolved into a myriad of solutions depending upon the context of the problem. However, this approach is dictated by the realization that no design problem for architecture in the developing world can be advanced without specifying in greater or less detail the peculiar aspects an architect encounters in this field.

Format

The thesis develops from the general to the particular - from an analysis of the broad considerations that dictate design and construction constraints in developing nations, to a specific case study involving particular housing problems and solutions.

(Figure 2: Diagram showing the format of the thesis)

Architectural Relevance

The approach utilized in this thesis - to present the nature of the problem in broad terms, and then aim for a limited but verifiably relevant design problem would, in any case, seem to lend itself to the demands of the architect.

It provides a corrective for the neglect of environmental and technical factors evidenced in current schools of architecture, with their concentration on theoretical, almost entirely graphic design solutions at the expense of economic, social and humanitarian concerns. In the case of developing countries, this approach attempts to answer the need to be both practical and deeply knowledgeable of special problems of the field, and to consciously articulate and combine both these facets in one work. It is highly unlikely that any other approach would yield successful results in a Third World context. The study of the design process was therefore born out of a necessity to understand the nature of the developing world's architectural problems before initiating an applicable design solution. (Figure 3: Chart showing a system approach for a housing project)

The World's 15 largest cities and where they are to be found

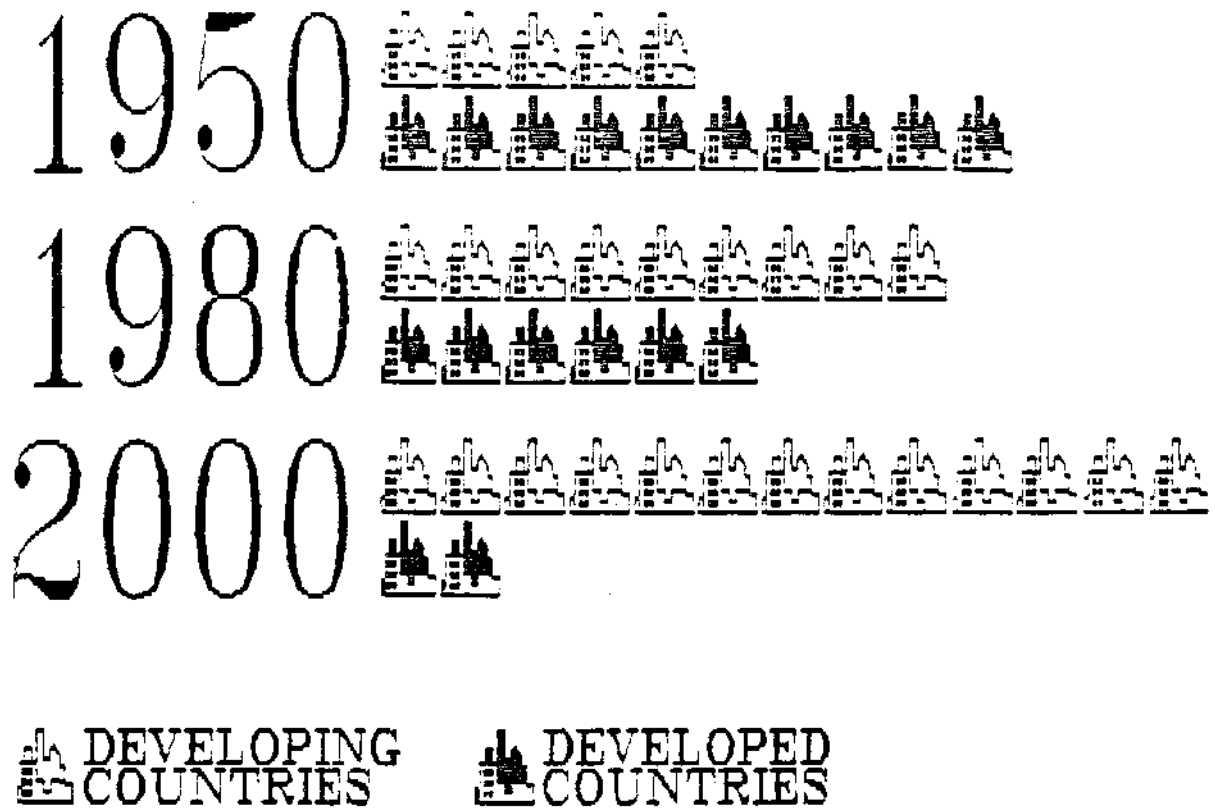

FIGURE 1

- Chart showing the world's fifteen largest cities in developed and developing countries: 1950, 1980 & 2000.

"Shelter Fact Sheet"
United Nations Centre for Human Settlements (HABITAT)
P.O. Box 30030, Nairobi, Kenya

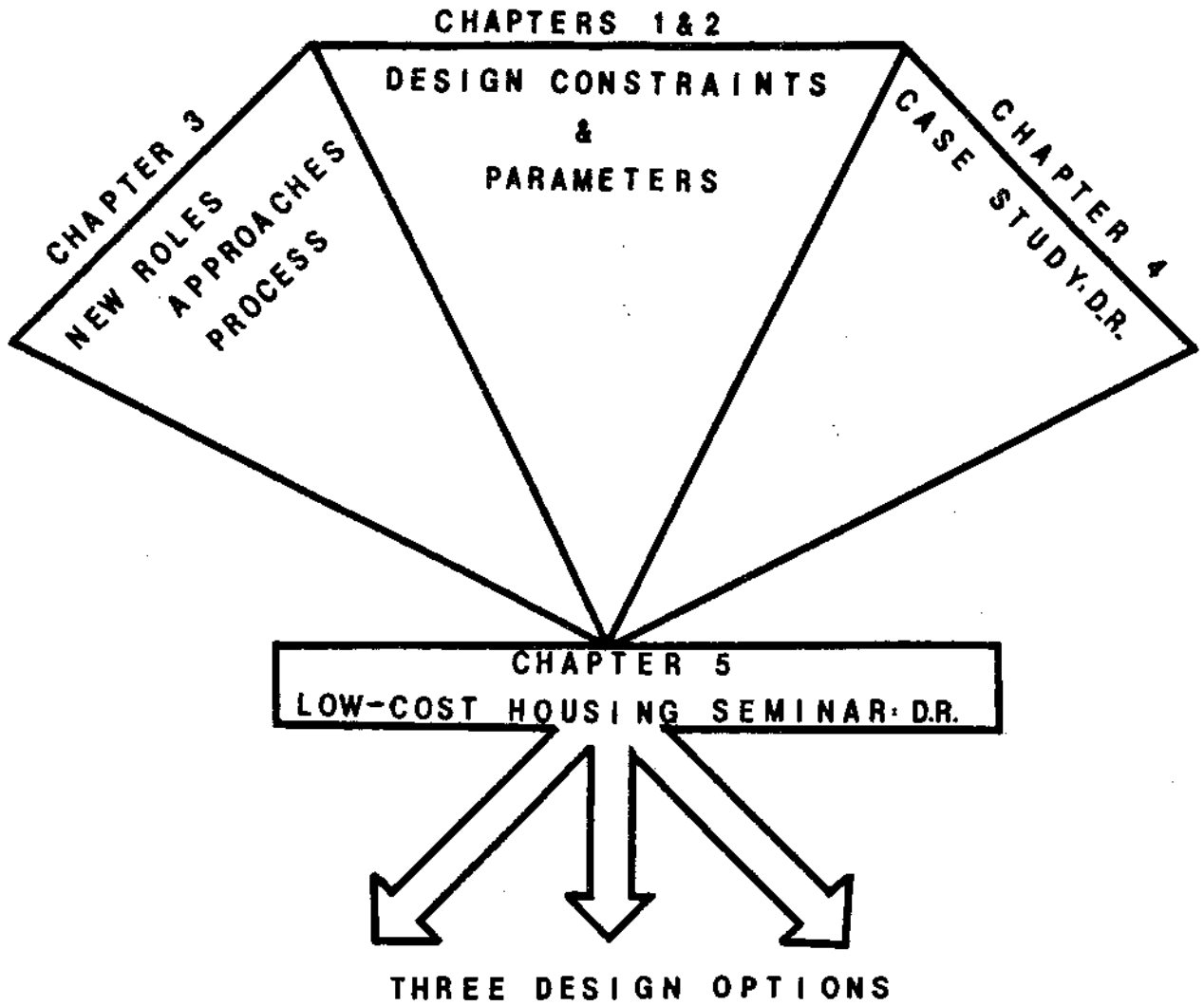

FIGURE 2

- Diagram showing the format of the thesis

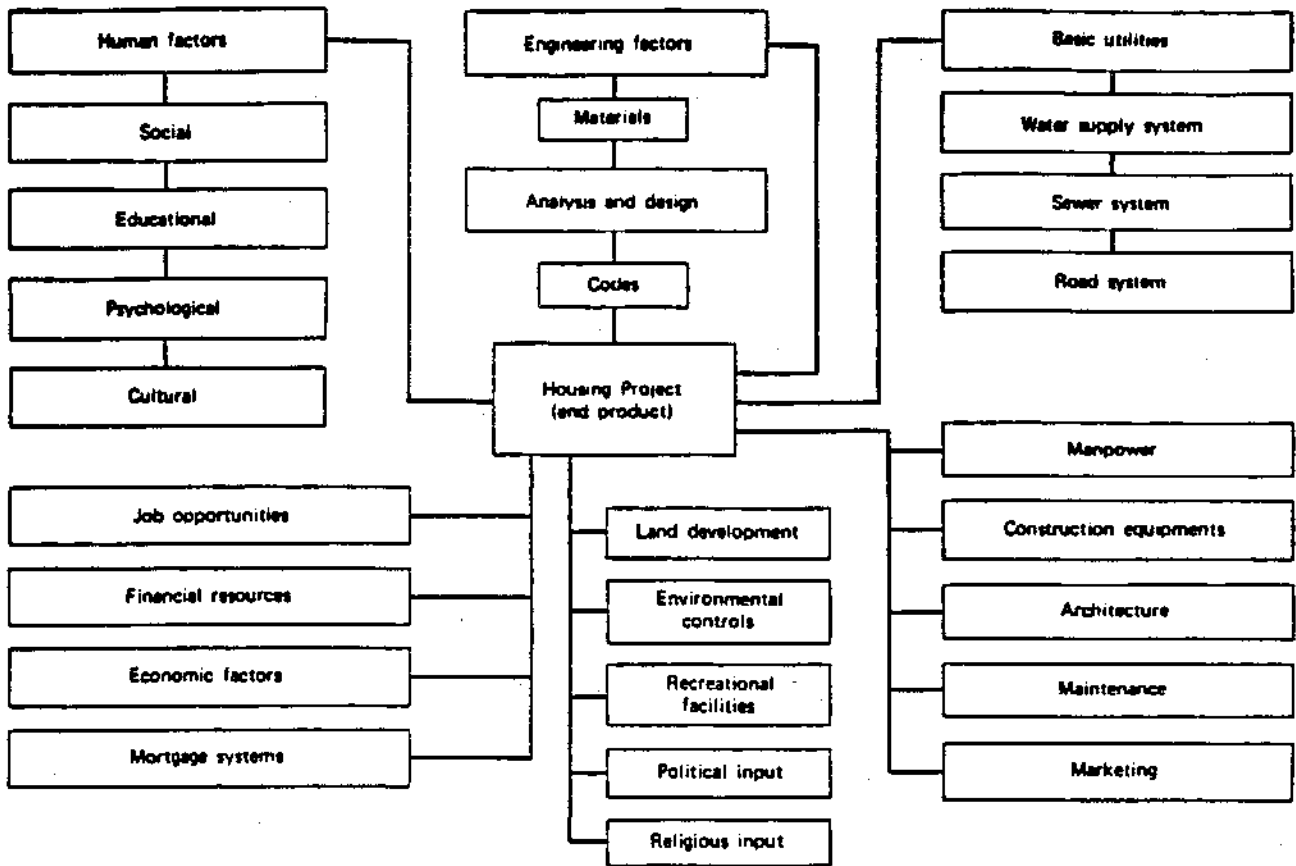

FIGURE 3

- Chart showing a system approach for a housing project.

Pg.4, "Construction of Lower - Cost Housing"
 Oktay Ural
 CONSTRUCTION OF LOWER - COST HOUSING
 Ed.Oktay Ural, John Wiley & Sons, N.Y.C.,1980

CHAPTER 1

DESIGN CONSTRAINTS FOR LOW-COST HOUSING IN DEVELOPING NATIONS

The process of achieving design insight into an architectural problem requires that the architect be fully aware of the constraints that will eventually shape the design solution. Architects from developed countries upon embarking on a design project in a developing nation inevitably find that the architectural constraints in a developing nation are more numerous and less clearly defined than in a developed nation. In designing housing for developing nations an architect will encounter numerous invisible barriers such as extreme poverty, cultural differences, and a general lack of building activity, among others, that add complex new dimensions to the architectural outcome. A brief examination of these invisible barriers is warranted.

Cultural Constraints

" There is a fundamental difference between the product of the architect as form-giver and symbol-giver and the symbolic elements that exist within the shelter of a vernacular society. The architect determines the forms that seem appropriate to the needs of a particular building or building complex within a society, while in the case of an indigenous society, the form of its dwellings is symbolic of its self-image. Vernacular shelter takes the form seen as appropriate to a society's nature, organization, family structure, aesthetic. The individual within a tribal or folk culture does not become the form-giver for that society: instead he employs forms that are essential to it, building and rebuilding within determinants that are as much symbolic as physical or climatic."

Pg.12, Paul Oliver
SHELTER, SIGN & SYMBOL
Ed. Paul Oliver,
The Overlook Press,
Woodstock, N.Y., Co. 1977

An architect trained in the tradition of mainstream design for conventional construction markets in the developed world will encounter limitations of professional relevance when designing for low-cost housing in the context of most developing nations. These limitations fall into three categories;

1. Assumptions of needs - The architect designs according to his own perception of a developing nation's housing needs as opposed to accurately assessing the native inhabitants' actual needs. Eg. An architect may prescribe a house where the support mechanisms ie. sanitation, water and transportation do not exist.

2. Assumptions of existing conditions - The architect unconsciously equates the design and construction options of a building site in a developing nation with that of a building site in a developed nation. Eg. An architect's design may call for prefabricated concrete parts when the construction skill and machinery does not exist to produce and assemble such building components.

3. Differing cultural concepts of functionality - The architect imposes mainstream design concepts of functionality appropriate for a developed nation in the context of a developing nation where concepts of

' usefulness ' are different.

A common example of this phenomenon has been the numerous designs put forth for high-rise apartment blocks to accommodate the inhabitants of high-density slums. In simple design terms, the apartment block represents the most efficient means of sheltering the maximum amount of people with the least amount of space. In reality, these structures, once built, are not cost-effective and provide unpleasant living conditions for the occupants.

Assumptions of Needs -

In the context of any developing nation, the architect must devote a great deal of research to discerning what aspect of low-cost housing requires architectural design skills. The boundaries of what an architect designs in the context of a developing nation are not as well defined as in a developed nation. The range of what an architect can design in a developing nation can include any aspect of living necessities - from a concrete oven to a hospital. In this respect, an architect can begin to understand the needs of poorer inhabitants by realizing what aspects of the inhabitants' living patterns should be exempt from external interference. Architects should be aware of the following guidelines:

- Tinkering with native living patterns can upset complex social habits with negative results. If the architecture

requires a drastic change of the inhabitants' life-style such as community relocation away from work and recreation, dis-satisfaction with the new community is insured regardless of the sensitivity of the design.

- Public facilities such as schools, community centers and hospitals do not take precedence over housing requirements. A community, in order to benefit from these facilities, must be secure and functioning properly. For example, a hospital cannot insure the health of a community if within the community there is inadequate sanitation, impure water supplies and infestation within the shelters themselves. Time for schooling may be unavailable if those who require schooling need employment and must commute great distances in order to work. Community centers of any kind, religious or otherwise, are useless in areas where there is no coherent social fabric eg. a squatting settlement. The larger scales in which these facilities are often envisioned negate their cost-effectiveness. Hospitals in the form of small clinics integrated into the community fulfill their function more adequately than large complexes that serve large dispersed areas. In addition to dispensing health services a hospital must be easily accessible. The same reasoning can be applied to other such public facilities that require community involvement.

- The architect's design decisions must reflect the existing conditions in addition to his own architectural values. The

existing cultural norms that manifest themselves in housing design may seem impractical to the architect - such as outdoor kitchens and latrines in many poorer tropical environments - but in fact have a sound basis in environmental design values accumulated through generations of vernacular construction.

At the other extreme, an architect should not mimic native construction unless he can verifiably improve upon it. Mimicking native construction often leads to simplistic or redundant design solutions. The architect serves best as an instrument of integration between native vernacular construction forms and new technology.

- A community's needs may not be architectural. They may be political, as in the case of land reform or granting property titles to initiate construction. They may be infrastructural such as providing adequate sanitation and water supply. In these cases, the architect must decide whether to relinquish these tasks to the political authorities and the engineers or to expand his own role to include tasks other than design. In the case of most developing nations, the professionals or the institutions required for these tasks are often unavailable; therefore the architect who has a wide range of skills is more beneficial to the construction environment.

Many architects have a tendency to over-design simple structures. An architect must be willing to consider

that the refinement of existing popular building materials such as concrete masonry units and wood may not be necessary. By the same token, the interior design of a simple two bedroom structure might be better left to the intended occupant. In the last analysis, the shelterless inhabitants may not need completed housing so much as the means by which to obtain adequate housing. In this case, the architect can respond by designing building systems conducive to easy construction and grass-roots level marketing processes eg. concrete block and corrugated metal roofing sheets in which building components are produced locally and purchased incrementally as the home-builder acquires the money to build.

Assumptions of Existing Conditions -

In the developed nations, the building site is often assumed by architects to be fully prepared to receive a structure. Before the plat reaches the architect, the building site has been zoned for a particular function, whether residential, commercial or industrial. An infrastructural system is assumed to exist to which the building's services can be connected. Transportation links are rarely causes for concern and the ownership of the site is undisputed. In most developed nations, a structure will not be built if its site lacks any of the previously mentioned features.

In many developing nations, however, an architect can expect to find;

- nonexistent or minimal zoning as a result of a considerable lack of planning,
- nonexistent or minimal infrastructure,
- unreliable transportation links,
- confused land ownership policies,
- inflated land prices kept artificially high by intransigent land owners,
- massive illegal squatting settlements,
- minimal or no state or civic jurisdiction over illegal communities, and a lack of dependable state, civic or private institutions capable of enforcing land ownership policies, zoning laws and building codes.

In the construction setting that is found in most developing nations, most construction projects are financially unfeasible and the public institutions responsible for building and maintaining a workable infrastructure are not fully reliable or operational. These problems combined with poor economic conditions and massive uncontrolled demographic shifts produce little or no incentive to improve living circumstances through housing construction.

In response to the difficult construction conditions that exist in developing countries, many housing authorities of the developed and developing nations alike

have agreed that centralized, hierarchical authorities cannot initiate housing as effectively as those in need of housing themselves. Related to John F.C. Turner's book and theory of "Dweller Control of the Housing Process," the role of architectural design has shifted from providing the large scale universal solution in the tradition of the 'ville radieuse' of LeCorbusier and the Modern movement in architecture, to an approach that emphasizes smaller, more manageable building components as well as the use of local building materials intended to provide incentive to the individual builder. Increasing the individual builder's incentive depends primarily on making housing design more efficient in the areas of cost, technical complexity, scale, durability and serviceability.

The source of the difficult construction conditions is to be found in the economic, social and environmental features of many developing nations. These economic, social and environmental features have a direct correlation to architectural design required to confront the difficult construction circumstances. In this respect, correctly reading the environmental, social and economic trends of a developing nation can lead to accurate design guidelines.

Cultural Concepts of Functionality -

When faced with the problem of housing shortages, regardless

of the context, most architects' reflexive response is to design low-cost housing by maximizing each building's occupancy at the lowest possible cost. This objective is usually achieved by calculating a lowest common denominator of the projected occupants' need for space and services. Though such calculations can be used beneficially, they often result in designs calling for massive apartment blocks or stretches of identical row houses that are barely livable, especially for the poorest occupants. Statistics in the short run suggest such housing projects have met their objectives by sheltering the maximum amount of people with the least amount of cost. However, the cost-cutting is usually at the expense of a long-term improvement in living conditions. The chart in figure 1.1 indicates that the value of an existing building which is an unsuccessful living environment will depreciate sooner, becoming in the long run a costly financial burden. Note how the graph for 'appreciation' is related to increased 'quality' and in effect determines how long the lifespan of the building will be before 'obsolescence'. 'Quality' in this case can be interpreted to mean the adaptive qualities of the building to the occupants' long-term lifestyles.

In response to the previous chart, a new 'function' design parameter can be developed for architectural endeavors in developing nations:

- Fulfilling the occupants' 'basic needs' cannot be the

only objective when designing low-cost housing. A building must adapt to its occupants or become obsolete. Put another way;

" It is not universal generalizations of basic needs which should have an impact on design, as so many Westerners think, but the particular patterns of eating, sleeping, dispensation of time, privacy, entertainment, the role of women and the structure of the family in all its aspects."

Pg.27, " The Need for Special Studies of the Problem of Third World Architecture"
Ronald Lewcock
ARCHITECTURAL ASSOCIATION QUARTERLY
Volume 2, No. 1, 1980

Misconceptions of function in regard to low-cost housing design for developing nations are often based on statistical studies related to environmental, sociological and economic research conducted in different cultural contexts. Statistics accumulated in a particular context are often applied universally in response to certain architectural design requirements, with the assumption that similar housing problems have similar design solutions regardless of location. The lack of statistical studies describing housing conditions in developing nations also influences architects to rely on contextually irrelevant information when developing their design responses. Consequently, inappropriate designs are generated at the planning level :

" The tendency in a number of countries is to copy complex codes of England, Germany or the United States as well as their zoning and planning laws, though they are irrelevant

and though the talents to enforce, construe and adapt them may be completely lacking. Zoning laws originally designed for countries with widespread automobile ownership may prescribe stores a mile away from the weary pedestrian's home."

Pg.62, Charles Abrams
 MAN'S STRUGGLE FOR SHELTER IN AN
 URBANIZING WORLD
 M.I.T. Press, M.I.T., Cambridge, Mass., 1970

Inappropriate designs are also implemented at the building and infrastructural level :

" ... codes for building and infrastructural facilities should be realistic to take account of local resources availability and should be flexible enough to make allowance for and take advantage of variations in local conditions. We, in India, suffer from a great lack of our own codes, particularly, with respect to public buildings. If we are to build our hospitals, schools and office buildings to conform to the same standards as in the richer countries, we will soon find we cannot afford to build very many. Yet since most physical requirements cannot be simply scaled down, much work remains to be done to develop our own standards. "

Pg.537, "The Role of Science and
 Technology in Improving Human
 Settlements "
 A. Ramachandran
 HABITAT INTERNATIONAL, Vol.5, No.3/4
 Ed. O.H. Koenigsberger & S. Groak
 Pergamon Press, Oxford, 1976

Architecture based on inapplicable design parameters out of necessity effects all the related building codes, zoning laws and support systems. In financial terms, a larger project of this nature can adversely influence a poorer nation's economy. The related human toll is incalculable but often highly visible.

Clients' Perceptions -

Architects from the developed nations are not solely responsible for design errors that occur in low-cost housing projects for developing nations. The task of providing adequate housing is complicated by the clients of developing nations harboring erroneous views of what constitutes 'progress' and 'development'.

In most developing nations where the general level of technical skill is low, architecture is the symbol of the nation's technical abilities. 'Progress' is associated with modern office buildings that rival those built in Developed nations. In this sense, modern architecture projects the image of 'progress' which in turn is equated with successful 'development'.

The clients that are responsible for this misconception cannot be isolated into one identifiable group. They range from the rural inhabitant who will not use cheaper and durable local materials in favor of imported construction materials because local materials are associated with 'provinciality' - to the president of the ruling elite who will needlessly build a dramatically modern and expensive 'cultural' center when much of his nation's populace is living in slums.

In most developing nations, there exists among the populace a severe lack of incentive to invest time and money in a long term project such as a house or a business because

of the constant threat of social and economic insecurity. Symbols of wealth and achievement become important. Visible and dramatic development projects provide symbolic proof that the populace is assured security and successful development or 'progress'.

The implementation of highly visible and dramatic development projects, however, take precedence over less visible, more necessary infrastructural problems and skill training programs. Those for whom the development projects are intended are encouraged to believe that the benefits of 'progress' will be made instantly available. Inevitably when such projects fail to meet the heightened expectations of those in need of housing, disillusionment with the system sets in, eventually generating seeds for social unrest. Hopeless poverty and disillusionment with the system create an unwillingness and inability on the part of poverty - stricken inhabitants of most developing nations to accept long-term development solutions. Financial aids needed for purchasing homes in the developed nations, such as bank loans and mortgage payments, are virtually nonexistent. In this respect, the concept of deferred costs and long-term financing is not fully realized among most inhabitants of developing nations. Consequently, implementing housing projects that require a lengthy period of sustained payment are for the most part, unfeasible.

Economic Constraints

The strongest factor determining the applicability of a housing design to developing countries is cost. The poor economic conditions of developing nations are the most evident obstacle blocking housing development. The economic constraints can be grouped into two types, the macroeconomic and the microeconomic.

Macroeconomic Constraints -

The financial problems of initiating the construction of a house in a developing nation are due to certain macroeconomic features typical to those nations, some of which are

- a cash - poor economy which
 - . undermines the value of the national currency
 - . decreases the average consumer's purchasing power
 - . discourages savings and investment;
- a lack of capital accumulation which
 - . prevents capital-intensive and long-term investment
 - . diminishes the productive capacity of the national economy
 - . fuels unemployment and costly trade deficits;
- runaway inflation compounded by the previous problems in addition to artificial price controls which
 - . deters market equilibrium between supply and demand at a certain price
 - . discourages long-term financing, investment, savings and a

stable economy.

These economic factors can be visualized as a cycle which remains in a state of unstable stagnancy . This cycle is sustained , in part, by periodic infusions of financial aid from the developed nations in the form of loans and subsidies which on one hand pumps needed capital into the faltering economies but on the other hand creates harmful dependencies on foreign aid. Conversely, the equilibrium of the cycle is continuously threatened by large population increases and uncontrolled demographic shifts within the developing nations themselves. An unforeseen natural disaster, war or revolution can cause sudden social and economic destabilization - the result of which can cripple a developing nation irreversibly .

Microeconomic Constraints -

Invisible at the macroeconomic scale, the numerous market imperfections at the microeconomic scale of a developing nation further complicate the task of initiating housing development. The major cost items of housing construction at the microeconomic scale are: land, building materials, labor and technical services. Each of these cost items have their respective sub-categories as indicated in the " Cost Items "chart (Figure 1.2).

A market imperfection pervasive in many developing nations is corruption. Costs of land, building materials,

labor and technical services are arbitrarily manipulated to suit the buyer or the seller. The cost of goods and services are, therefore, not representative of accurate market prices. Without accurate market indicators to monitor the supply and demand of goods and services an imbalance occurs between the supply of housing and housing demand. Inflated land prices and squatting communities are symptomatic of the imbalance between housing supply and demand causing market conditions conducive to market imperfections such as corruption. Corruption is also evident in societies where a highly visible discrepancy exists between a small number of opulently wealthy rulers and the bulk of the population which subsists at a low standard of living - made obvious by the lack of adequate housing.

The microeconomic and macroeconomic implications of promoting housing development are too numerous and complex to cover in this study alone but some of the more obvious financial constraints to initiating housing construction can be grouped into three categories: housing investment, financing housing construction and construction costs.

Housing Investment -

The initial problem connected with generating investment in housing originates in the traditional economic definition of housing as

" a (consumer) durable form of investment requiring a substantial outlay to create it but paying off little per year. It generates no foreign exchange, competes with industry and agriculture for capital, draws off needed labor and materials, and may even be inflationary. " Pg.106,

Charles Abrams,

MAN'S STRUGGLE FOR SHELTER IN AN URBANIZING WORLD

M.I.T. Press, M.I.T., Cambridge, 1970

This economic perspective suggests that housing is low on the list of development priorities requiring expenditures, both from within the developing country and from without in the form of foreign aid and loans (Figure 1.3). The accuracy of this theory is currently questioned.

" To a performer involved within the scene of designing or producing low-cost housing over the past three decades it is clear that a distinct gap now exists between :

- the economic theories about development which included, or alluded to include housing ;

- and , the applied economics implicit in the design and production of low-cost housing schemes for the developing countries.

As Lipsey says (8) economic theory is meant to be about the real world but all too often it is taught merely as a logical analysis, only vaguely related to the world; similarly applied economics is taught as description unenlightened by any theoretical framework. Although the gap is introduced by inadequacy of knowledge, there is no reason why it should continue if empirical observations be sought."

Pg.983, "Low-Cost Housing in Developing Countries: Planning the Organization of Effective Programmes"
Gilbert Turner,

HOUSING : PLANNING, FINANCING, CONSTRUCTION Vol.2
Proceedings of the International Conference on
Housing, Planning, Construction , Dec. 2-7, 1979
Miami Beach, Florida

Ed. Oktay Ural, Pergamon Press, N.Y.C., Co.1979

Classifying housing as purely a 'consumer durable' is a limited definition of housing's economic value - convenient in a theoretical framework. In 'applied economics', however, this perspective is subjective. In the context of poorer developing nations distinctions between 'residential' buildings and 'commercial' buildings are increasingly blurred. Many families provide services from their homes. Homes are also potential sources for fledgling cottage industries. Promoting housing construction is also conducive to a wider range of economic activity because of the 'multiplier effects' inherent in the building industry. Aside from the more obvious economic benefits, secure housing also forms the basis of stable communities which increases the potential for steady economic development.

In conclusion:

" A United Nations Mission on housing (11) reporting in '64 said: "One of the most common generalizations is that housing expenditure requires too many inputs and produces too few outputs and should therefore be subordinated in the priority of expenditure." An economic analysis correct by conventional accountancy and classification, where fewer inputs imply greater economic efficiency and the main output is (non-productive) welfare. However to countries with problems of vast unemployment, industries with many inputs are more desirable than those having few and should housing be accounted objectively it can be seen to be a sub-order of labour as a 'factor of production' in much the same way and for much the same reasons as the machines used by labour are a sub-order of Capital as a 'factor of production'." Pg.986 (Ibid.)

Financing Housing Construction -

In 1972 the World Bank initiated development projects with one of the main objectives being

" - To shift the financial burden for urban development from the public sector to the private sector and the urban population itself."Pg.3, LEARNING BY DOING, World Bank, Washington D.C.,1982

The new policy of development called for strategies to harness the untapped financial resources of the 'informal sector.' To those inhabitants of developing countries who suffered from a lack of adequate housing were delegated the financial responsibility of providing housing for themselves. In order to execute the first objective the World Bank development initiative called for a second main objective :

" - To direct (development) investments to the needs of the urban poor, who constitute the majority of the urban population in most Developing countries." Pg.3, Ibid.

In light of the numerous costly attempts at housing development prior to the World Bank's shift in which public institutions of developing nations were encouraged to provide for the low-cost housing needs of the population, the new direction in housing policy seemed logical. In reference to those development projects prior to 1972, a World Bank report stated:

" Then as now - rapid urban growth in all regions of the developing world was placing enormous demands on public institutions, which often lacked technical expertise, institutional capacity and financial resources to respond. The Bank approached these problems by adopting a research

and development strategy that differed markedly from the previous investment policies in urban services. It advocated new low-cost approaches in shelter and infrastructure, which were intended to mobilize private savings and to relieve the public sector of most of the financial burden for urban services ."Pg.1, Ibid.

The obstacles involved in shifting the financial burdens of housing construction to the individual in the 'private sector' of a developing country, however, remain complex and numerous. In order to finance the construction of his own house the average poorer inhabitant of a developing country must face the following financial constraints

- no stable financial institutions,
- no secure credit,
- currency with little purchasing power,
- unchecked inflation acting to devalue savings,
- nonexistent or poor mortgaging systems,
- unemployment.

These financial constraints lead to

- a lack of long-term financial planning,
- and little incentive among poorer inhabitants of developing nations to build or purchase a house.

In response to these obstacles, the World Bank's development initiative of the seventies had a secondary set of objectives:

- To demonstrate low-cost technical solutions for shelter, infrastructure, and transport which the urban population could afford and which could be improved over time;
- To demonstrate that it is possible to provide services for for most of the urban poor on a non-subsidized basis;

- To demonstrate the feasibility of comprehensive urban planning and investment procedures suitable to rapidly changing urban conditions;

- To demonstrate the replication of the projects incorporating these objectives, that is, the ability of such projects to be self-financing and self-sustaining and thus to be extended or reproduced elsewhere." Pg.5, Ibid.

The World Bank objectives conform to a form of development described by Charles Abrams as 'inducement.' Charles Abrams defines the 'inducement' means of development as :

" - giving considerations in one form or another to lead to a desired action. Such considerations includes subsidies, guarantees, concessions, loans, favorable tax policies, tariffs, and other such aids to stimulate investment or venturing. "

Pg.218, Charles Abrams,

MAN'S STRUGGLE FOR SHELTER IN AN URBANIZING WORLD

M.I.T. Press, M.I.T., Cambridge, Mass., Co. 1970

In this case, 'Inducement' coupled with 'free-enterprise' or 'laissez-faire' marketing techniques is intended to provide those who lack housing the incentive to take charge of their own housing problems and possibly turn a profit by generating a business related to construction.

An example of an 'inducement' in housing construction is Charles Abrams' 'roof loan' scheme. Abrams suggests that incentives can be provided to a higher number of prospective homeowners to house themselves if, upon completing the simpler stages of construction ,ie. the foundation and walls, they are provided with the construction of a roof requiring no initial payments. The

success of such a plan is based on the flexibility given the potential homeowner to meet the eligibility requirements at his own pace without any financial leverage. The lack of emphasis on complicated financial transactions is conducive to the cash-poor economies of developing nations. The 'roof loan' scheme, as a result, avoids the necessity for long term financial planning and requires less savings on the part of the potential homeowner.

Construction Costs -

In developing nations the construction process is often hampered by fragile economic conditions. The logistics of a construction project can be complicated by unpredictable spurts of inflation which render useless cost estimates and building schedules calculated prior to the initiation of construction. The procurement of building materials becomes especially difficult. Millard Fuller, executive director of 'Habitat for Humanity' recounts the effect of 'runaway' inflation on his building project in Zaire in 1973;

"... within a year, however, runaway inflation forced us to make changes. Cement increased in price from \$1.60 a sack to \$2.90. Construction wood increased from \$55.00 a cubic meter to \$130.00. Tin went from \$ 4.00 a sheet to \$6.00. Roofing nails increased from \$50.00 to \$180.00 !"
Pg.140, Millard Fuller

BOKOTOLA,
Associated Press,
Follet Publishing Company,
Chicago, co.1977

The unpredictable price fluctuations of building materials can lead to related construction obstacles

- Price fluctuations may affect the availability of materials.
- Irregular material availability causes costly construction over-runs.
- Construction over-runs necessitate lay-offs and design short-cuts in order to reduce cost.

Suppliers can also take unfair advantage of price fluctuations at the expense of the builder.

" Early in the project, we were buying cement at \$11.00 a bag. We paid for it in order to be assured the old price. Four months went by, but no cement came. Then we received a letter informing us that the price had increased and that we must spend an additional ninety cents per bag to get delivery on our order."

Pg. 81, Ibid.

The complications that can occur during the construction process due to adverse economic conditions suggest that the scale of construction projects in developing nations should be kept at manageable levels. Large scale projects require complex logistical support systems . Industrially manufactured prefabricated building systems are also logistically complex and financially risky endeavors for developing nations, regardless of scale. In this sense, the proliferation of industrially manufactured prefabricated building systems as well as large scale construction projects can contribute to an irreversible debt problem for a poor nation.

"In poorer nations especially, the relationship of building technology employed by architects, to the practicality of the building program is profound. Not only does it affect the speed of erection, the full employment of labor, and the

practicability of maintenance, but it can also affect such diverse aspects as the adverse balance of payments of the international trade of the country in question. On the whole, it can be said that large complex building projects should be avoided and replaced by projects which can be implemented in a large number of increments, permitting a more gradual rate of growth. "

Pg.26 - 29. "The Need for Special Studies of the Problems of Third World Architecture"
 Ronald Lewcock, Architectural Association Quarterly, Vol.12, No.1,1980

Large scale construction projects and industrially manufactured building systems in developing nations should also be discouraged for the following reasons:

- The cash-poor economies of developing nations cannot absorb capital-intensive construction techniques.
- The purchase of foreign materials, machinery and labor represents a nonrenewable drain on domestic cash reserves.
- Maintenance costs also contribute to a nonrenewable drain of domestic capital.

In conclusion, an additional design parameter for architecture in developing countries becomes evident :

In a developing nation, the logistical complexity of a construction project is a major determinant of the project's financial feasibility. A construction project will become less financially feasible as the logistical complexity increases. A construction project ,therefore, should be kept manageable by

- reducing construction scale down to small/low-cost components.
- using locally available construction materials.

Technical Constraints

The technical concerns of construction in developing nations are related primarily to economic feasibility. The design parameters of residential architecture are almost exclusively oriented towards making housing affordable in the poor economic conditions of developing nations. To achieve the goal of affordability the architect must concentrate on

- manageable logistics,
- cost-effective building construction,
- the replication of building methods,
- appropriate technology.

Currently the most effective means of achieving housing 'affordability' is by ;

- reducing scale,
- increasing construction tolerance for unskilled labor,
- increasing the availability of local construction materials,
- localizing the procurement and transportation of materials and labor.

In order to better comprehend the means of achieving housing affordability in the context of developing nations, the designer/builder must first be aware of the most commonly encountered obstacles. The construction obstacles in developing nations are summarized in the following description of the difficulty of constructing company

appropriate housing system, the designer in particular must be completely aware of what the consequences of his design will be to the eventual occupants. John F.C. Turner's second and third laws of his three laws of housing succinctly summarizes the architect's responsibilities towards his clients:

" Turner's Second Law says that the important thing about housing is not what it is, but what it does for people's lives, in other words that dweller satisfaction is not necessarily related to the imposition of standards.

Turner's Third Law says that deficiencies and imperfections in your housing are infinitely more tolerable if they are your responsibility than if they are somebody else's."

Pg.xxxiii, Preface by Colin Ward
HOUSING BY PEOPLE, John F.C. Turner
Pantheon Books, N.Y.C., Co.1976

Under the severe economic constraints of the developing nations an architect must ensure that the design project's probability of failure or 'risk' is reduced to a minimum for the intended client/occupant. 'Failure' may entail

- the project's failure to meet the intended demands ie. affordable housing,
- the collapse of the project's support mechanisms,
- requiring detrimental design and construction shortcuts as well as cost and schedule over-runs,
- the abandonment of the project as a whole,
- a combination of the previous prospects.

In order to derive the housing system most suitable in the context of a developing country's construction

environment, the architect/builder must examine existing building systems. In developed nations, where more construction alternatives exist, building systems can be divided into three groups according to their levels of complexity. The complexity of these systems are related to amount of industrialization required to manufacture and assemble these systems. In order of complexity and required industrialization the building systems can be listed as :

1. building technology requiring full industrialization - or 'full industry' systems,
2. building technology requiring partial or small scale industry - or 'partial industry' systems,
3. building technology requiring no industry - or 'nonindustrial' systems.

Full Industry Systems -

These building systems are the most complex to implement. Building systems commonly associated with this level of construction are

living units:

Self-contained living modules, prefabricated and pre-assembled before their installation at the site.

examples: - Moshe Safte's 'Habitat', Montreal Expo. 1967

- Buckminster Fuller's Dymaxion house

- Kurokawa's Nagakin Capsule Tower, Tokyo

large scale structural components:

Otherwise known as 'system building'. Structural components are prefabricated and then erected on site. 'Heavy' systems ie. concrete prefabricated components manufactured on site. 'Light' systems ie. steel components mass-produced off site.

examples: - 'Heavy': Collin & Krondstadt, Leaby, Hogan & Collins architects, National Association of Home Builders & Portland Cement Association, Research House VII, Washington, D.C.

'Light': Dalton & Dalton architects, Steel Framed Pre-finished Housing Units, Cleveland

Full industrialization is the most advanced state of development a nation can obtain. Four degrees of industrialization represent the level of technical complexity required before a nation can attain full industrialization;

- . Standardization,
 - . Labor Specialization,
 - . Concentration,
 - . Mechanization.
- ||
 ||
 ||
 ||
 ||
 \/
 Full Industrialization

- Standardization : A nation in order to facilitate the later and more complex stages of industrialization must

first create a set of checks and balances to regulate the construction industry. This is accomplished by creating a set of construction standards that all manufacturers, designers and builders can follow. This step is initiated by establishing a firm set of building codes and zoning laws that are applicable to the existing construction environment and enforceable.

- Labor Specialization : As the scale and scope of construction projects increase, the sophistication of the construction industry must increase as well. Construction tasks inevitably become more complex, increasing the demand for expertise in certain areas of the construction process. The subsequent division of labor implies a move towards 'specialization'. The specialization of labor requires an educational and testing system that will ensure that the quality of specialized tasks is maintained. Training programs, apprenticeship and licensing exams become obligatory.

- Concentration: The scale and complexity of a construction industry is proportionate to its means of supply, financial scope and its organizational capacities. The ability of a construction industry's network to move large amounts of construction materiel consistently and on schedule, to manage diverse labor requirements effectively and efficiently and to attract capital-intensive investment is essential in promoting construction growth. Large scale, complex and long-term projects require the 'concentration'

of capital, materiel and labor to achieve the intended results.

- Mechanization : The utilization of machinery for construction purposes is associated with the most advanced levels of building technology. Mechanization facilitates rapid construction with large scale components. Mechanizing the construction process is only cost effective in countries where labor costs are high and labor is limited. Introducing construction machinery to the building process requires an efficient logistical network . In addition to the construction process, the construction machinery must be kept operational and must be easily transported from one site to the next.

Developing nations are not fully industrialized. Many developing nations are currently struggling to achieve the first level of 'development' i.e. 'standardization'. At this point, an architect searching for an appropriate building technology to implement in the context of a developing nation can assume that a building system requiring any degree of sophistication beyond the level of 'standardization' is prone to failure and represents a higher risk to the prospective Third World client/occupant. As represented on the chart in figure 1.4, the degree of 'risk' increases with higher levels of industrialization.

Partial Industrial Systems -

A 'partially industrial' building environment generally describes the localized cottage manufacturers of smaller, less costly construction materials, components and kits. These materials, components and kits are less complicated to utilize than the 'full industrial' systems and are directed towards a larger less skilled construction market. These materials, small components and kits are often manufactured independently by different producers and are intended for limited use. For example, They may be used for sheathing purposes or structural purposes but must be used in conjunction with other such materials and components, also manufactured by different producers. There are a wide range of such materials, components and kits available in the American housing market. The sophistication of the materials and components range from items available in 'Sweet's' catalogue in the United States to commonly available materials and components in developed nations such as corrugated tin, plywood, concrete block and gang-nail trusses. 'Log Cabin' or 'Geodesic Dome' kits are complete housing packages commonly advertised in construction publications in the United States.

Some architects credited with innovative design implementing small scale components, materials and kits are - Christopher Alexander, known for his designs involving a

number of low-cost building systems ranging from mortarless concrete components to bamboo reinforced concrete beams.

- Charles Eames with his 'Case-Study House' located in Santa Monica, California, built entirely out of catalogue ordered parts.

- Frank Lloyd Wright in his use of concrete block for the low - cost 'automatic' houses.

Partial industrialization can also be viewed as the intermediate stage of 'development' between an agrarian, nonindustrial society and a 'developed', fully industrialized society. Partial industrialization also requires the four degrees of full industrialization i.e. standardization, labor specialization, concentration and mechanization but at levels that demand less skilled labor, capital-intensive financing and sophisticated technology.

The three types of building systems conducive to partial industrialization in order of complexity are:

- elements or materials,

- components,

- packages or kits.

||
||
||
||
||
\\

Most Complex

The complexity of implementing these systems is proportionate to the risk of failure these systems pose to the prospective client/occupant. As the complexity of these systems increase so does the risk to the client. The

amount of construction tolerance allowed when these systems are assembled define their level of complexity. For example, kits or packages allow little tolerance for mistakes in the manufacturing or assembly process. The components of a kit usually can only be utilized in one way. If a part is lost or damaged the risk exists that the building kit as a whole will lose its structural integrity.

(Figure 1.5 : Chart showing the potential risk to public agency and potential for private return of building systems requiring packages, components and elements.)

Nonindustrial Systems -

Housing construction that is nonindustrial falls into three categories: 'vernacular', 'folk architecture' and 'appropriate technology' and entails the use of indigenous organic materials available within the immediate location of the site.

- Vernacular: 'Vernacular' construction describes the most traditional use of indigenous materials and simple building methods that have existed since men first constructed shelter. Conical African huts with packed earth floors, walls of mud and wattle or mud bricks and roofs of thatched grass or palm leaves is an example of traditional vernacular construction. In the southwestern United States American Indian vernacular exists in the form of adobe 'pueblos' constructed by the Pueblo Indians. In a primitive rural context vernacular construction is a direct building

response to the immediate environment which has evolved over generations with little variation. In sparsely settled regions and/or harsh natural environments little variation of the basic principles of design are needed because the existing means of vernacular construction provides the most efficient form of shelter, eg. the Eskimo Igloo. The purest form of vernacular construction requires no cost, little labor and can be built with materials available within the vicinity of the site.

- Folk Architecture: Folk architecture is a derivative of vernacular and essentially describes the same form of construction. The building materials are indigenous and the construction methods are simple. Folk architecture differs from vernacular in that it is more related to the social needs of the community and reflects that association through the construction techniques. The traditional Japanese house, for example, is more suited to the warmer, tropical climates of southeast Asia than the cooler, seasonal climate of Japan. However, the modular, open plan style of the traditional Japanese house is a manifestation of the Japanese lifestyle. In the United States, the severe but graceful architecture of the Quakers shows a similar emphasis for the lifestyle of the Quakers rather than the local environment.

- **Appropriate Technology:** Appropriate Technology is a new field in building construction and was created with the intention of combining the traditional methods of vernacular construction with newer low-cost technology. Some examples of the innovative products of experiments in Appropriate Technology include

- the CINVA - ram; a portable mechanical device used for making soil-cement blocks,
- bamboo reinforced concrete,
- fiber - cement roofing panels and tiles,
- sulphur treated cardboard also used for roofing tiles.

To reiterate, the vernacular, folk architecture and appropriate technology building systems all emphasize self-sufficiency in all the aspects of the construction process

- Construction costs are kept to a minimum. The materials used are available in the immediate vicinity.
- The building technology incorporates knowledge developed from the exclusive use of indigenous materials.
- The building technology incorporates the skill level of labor available in small rural communities.

Though non-industrial building technology is the lowest-cost and the easiest to implement of the various construction technologies, it is unsuitable for use in heavily populated areas for the following reasons:

- Buildings built of cheap, indigenous materials are not

durable. Roofs made of organic materials are flammable and susceptible to infestation. Soil based walls must be protected from excessive moisture.

- Non-industrial materials require much maintenance. Organic roofs become water-logged and leak unless constantly maintained. Soil based walls crack in excessive heat and crumble if exposed to too much moisture.

- The local materials must be sparingly used, allowing those materials that are renewable to grow back and materials that are not renewable - not to be depleted. Heavily populated areas require more building resources and risk ecologically damaging the immediate environment if their construction needs are not supplemented from outside sources.

- Non-industrial construction techniques are often time-consuming and therefore are not cost-effective in projects that require paid labor.

- Non-industrial materials and structures have limited structural capacities. Buildings constructed of soil based or organic materials are rarely built over two stories. Soil based construction materials must be heavily reinforced in earthquake zones and organic materials must be adequately fire-proofed. Builders in developing countries often lack the means and the skill to accomplish these ends.

In conclusion, non-industrial technology suffers a 'performance' risk. Proportionately less use of industrial

materials and construction techniques generate a higher 'performance' risk. 'Performance' risk describes a combination of

- weaker materials,
- weaker structure,
- cruder construction technology.

(Figure 1.4 : Chart showing a curve representing performance risk in relation to nonindustrial technology, cost and industrial technology.)

Social Constraints

Two sources of social dysfunctions in developing countries which hamper housing development are;

- large demographic shifts due to an unprecedented population explosion in many developing nations,
- the inability of the social networks of Developing nations to absorb the impact of the current population explosion and the consequent lack of integration between the 'informal' and the 'formal' sectors in developing nations.

Demographics -

The lack of adequate housing in the urban areas of developing countries is symptomatic of an on-going population explosion currently generating large demographic shifts from the rural areas to the urban areas. The generally younger, predominately male and unskilled rural inhabitants coming to the cities are primarily in search of employment and an improvement of status. The

tropical climate of most developing nations and the migrants' lack of family concerns combine to make adequate housing low on their list of priorities.

The result is drastically overcrowded urban areas in most developing nations which are characterized by the proliferation of large squatting communities located in unused land pockets within and around urban areas. These squatting communities contain closely packed shanties made of available construction debris, for example, discarded wood, plywood, corrugated metal sheets, cardboard, flattened cans and other such salvageable materials. The shelters are purposely built to be 'temporary' in the event that local authorities try to evict the inhabitants or the inhabitants need to move in search of employment opportunities.

The locations of these squatting communities vary, but are characterized by the inhabitants' needs to be located near areas of employment. As a result, the squatting communities are dispersed throughout the city wherever the inhabitants can get a foothold. Such areas include empty lots, dead end alleys and areas where the more firmly established residents of the city will not build such as flood plains, earthquake zones and other such disaster-prone areas. The locations of squatting communities are also determined by the inhabitants' mobility. Urban planners refer to this phenomenon as 'poverty bubbles.' If squatters

are evicted from one area or discouraged from living in others, they inevitably find new locations to settle within reach of employment. In other words, housing authorities enforcing zoning regulations cannot eradicate squatting communities - only disperse them.

The characteristics of the shelters in squatting communities also reflect the preferred lifestyle of the inhabitants. The temporary nature of the shelters are cost effective. They cost virtually nothing to build or maintain and do not present an anchor requiring permanence if the inhabitant wishes to move on in search of improved employment. In other words, the shanties of squatting communities often represent ideal living circumstances for the young, mobile migrant worker with no cash savings to spend on rent or mortgages. Consequently, it is difficult for housing authorities desiring a more orderly development process to discourage the proliferation of squatting communities.

The result of this split between the established inhabitants and the migrant new-comers are two divergent societies within one. The subculture and the internal economy of the squatting communities are referred to as the 'informal sector' and the established urban inhabitants representing the interests of the national economic and political stability at large are known as the 'formal sector.' Though the 'formal sector' of developing countries

represents the interests of the nation as a whole and is credited with sustaining the national economy and implementing national policy. the 'informal sector' represents the overwhelming majority of urban inhabitants in the developing world.

Informal Sector -

To reiterate, the informal sector is characterized by

- the majority of urban dwellers in developing countries whose social existence has little bearing on the national economy and national policy of developing nations,
- slums and squatting communities, most of which are considered illegal settlements by the civic and government authorities alike,
- unregulated commerce and construction that constitutes a 'black market' within the framework of the larger legitimate national economy,
- unregulated activities including settlement and social unrest beyond the capacities of the civic and government authorities to monitor or control.

The unregulated existence of developing nations' informal sectors poses severe constraints to the conventional operation of government policy in regard to national development. The initial goal of achieving construction 'standardization' is hampered if zoning laws and building codes cannot be enforced.

Zoning:

Squatting communities by definition are settlements constructed without regard to zoning laws or ownership. Often these settlements are built in disaster-prone areas such as earthquake zones and flood plains. In the event of natural disasters squatting communities are susceptible to disproportionate casualties. Disaster reparation is beyond the economic, political and technical capacities of most governments in developing nations - leaving the victims depending on foreign aid.

The lack of zoning constraints and, by the same token, existing zoning laws that are poorly implemented, also lead to overcrowding and the lack of infrastructural facilities. The resultant communities are prone to;

- conflagration,
- unsanitary conditions,
- disease epidemics,
- social unrest,
- ecological collapse of surrounding natural resources.

Building Codes:

As with zoning laws, unheeded or poorly implemented building codes can breed inadequate living conditions among inhabitants of the informal sector. Squatting communities generally suffer a high rate of unnecessary casualties per dwelling because of collapse due to;

- overcrowding,
- inadequate structures,
- inadequate materials,
- poor construction techniques.

The informal sector also suffers a high rate of casualties due to a lack of construction precautions against ;

- disaster,
- unsanitary conditions,
- infestation,
- fire,
- social unrest.

- Formal Sector

The political upheavals and constant social unrest of most developing countries are indicative of the precarious role the members of the formal sector take in attempting to control the development of those in the informal sector. Buildings and communities are regulated by building codes and zoning laws which are facsimiles of codes and laws in the developed nations and are not applicable in native environments. The consequence of these attempts at achieving standardization is that the codes and laws are ignored by the urban population at large, i.e. those of the informal sector, unless the laws are brutally enforced.

Successful development depends upon the integration of the formal and informal sectors. One step in achieving

this integration is changing the conventional view of housing authorities, urban planners and architects alike, that the squatting communities, shanty towns and slums are a blight to development and should be eradicated. Charles Abrams suggests that these manifestations of the informal sector be regarded as a painful step towards development.

"It may be conceded that in the formative years of industrialization, the slum will be the inevitable by-product of urban development, like the abdominal distortion that precedes birth and growth. The trouble has been that reformers have always called the swelling a cancer to be excised wherever it appears."

Pg.125, Charles Abrams,
MAN'S STRUGGLE FOR SHELTER IN AN URBANIZING WORLD,
M.I.T. Press, M.I.T., Cambridge, Mass. Co.1970

John F.C. Turner goes a step further, stating that the inhabitants of the informal sector adequately shelter themselves according to their needs and means and that all forms of housing authority and regulation should be relinquished. Turner's first law of housing states;

" When dwellers control the major decisions and are free to make their own contribution to design, construction management of their housing, both the process and the environment produced stimulate individual and social well-being. When people have no control over, nor responsibility for key decisions in the housing process, on the other hand, dwelling environments may instead become a barrier to personal fulfillment and a burden to the economy."

Pg.241, "The Meaning of Autonomy",
Robert Fichter, John F.C. Turner, Peter Grenell,
FREEDOM TO BUILD, Ed. John F.C. Turner, Robert Fichter
Macmillan Pub. Co., N.Y.C., Co.1972

Currently many international organizations have opted to

follow Turner's advice and disengage themselves from the construction of building projects. International organizations oriented towards housing development in developing countries have retired into functioning as 'information brokers' such as the World Bank, or consulting agencies concerned primarily with the dissemination of information.

Political Constraints

Architects from developed countries, when designing for developing countries, are faced with the initial constraint of having to justify their intentions. Questions arise as to whether the traveling/visiting architect's intentions are pure and if they are.....for what reasons should an architect embark on such a task? In the United States the issue is a personal one. In a developing country the issue has political overtones. In the eyes of an inhabitant of a developing country the visiting foreign architect is usually viewed in one of two ways:

- As an instrument of developed nations sent to exploit inhabitants of the developing world.
- As a form of assistance from the developed nations sent to aid the inhabitants of the developing world.

Accepting assistance from the developed nations is a contentious issue among many inhabitants of developing nations. The anti-assistance camp fears that accepting aid

from the foreign architect is opening the door for later more exploitative measures, i.e. increasing the exorbitant debt many developing nations already face. The pro-assistance camp cautions that the only salvation to the developing world's problems lies in accepting aid from the developed nations. Politics of this nature is often unconsciously applied to existing construction projects.

Projects that are initially an architectural concern can become political scapegoats or symbols of a new regime's progress for reasons unconnected with the social value of the architectural endeavor itself. Native housing reformers of developing nations often gravitate into 'pro-Western' camps or 'anti-Western' camps, each espousing different building systems because of the political implications.

Political partisanship is generally reflected in the building system chosen. For example, extravagant civic centers, banks and high-rise apartments advertise the aspirations of the well-ensconced elite of the powerful upper classes, while sprawling proletarian barracks for the poor represent the communal concern of Marxist-oriented reformers. Nationalists, trying to promote the cultural identity of their countries, idolize picturesque imitations of the local vernacular. Bankers and entrepreneurs of developing nations predictably push pre-fabrication systems or some form of manufactured building process, because of the prospect of creating a highly

profitable industry with a virtually limitless market demand. As a general rule, the government favors any large scale development that out of organizational necessity calls for centralization with a government housing ministry in control. Rebels or those opposed to the government often ignore architectural considerations altogether and call for 'land reform' or back highly localized forms of housing development such as 'appropriate technology' which entails construction with materials available in the immediate vicinity of the site.

What is often overlooked, is that a healthy housing industry, a government agency capable of enforcing construction standards in a humane fashion, land reform and the capacity to maximize the use of local materials are all equally important aspects of housing recovery.

Urban Land Reform:

- Artificially inflated land prices act to discourage the legitimate purchase of land and encourages the influx of poor migrants to illegally settle in urban areas.
- Alleviating squatting communities depends upon the equitable distribution of building plots to ensure legitimate tenure.
- Land tenure provides incentive for long term construction investment.

Rural Land Reform:

- Numerous tenant farmers have no ties to the land. In this respect, rural inhabitants searching for an improvement in social status migrate to urban areas.
- Established native landowners and agribusiness enterprises present obstacles to equitable land distribution among rural inhabitants.

Appropriate Technology:

- Rural inhabitants are cash-poor. Purchasing construction materials from a nonlocal source induces debt. Debt requires cash infusion. Indigenous materials for building must be developed to curb the use of imported materials. A self-sufficient rural population helps prevent massive uncontrolled migration to the urban areas .

Strong Government Agencies:

- Generating transitions to equitable land policies depends upon the long-term organizational capacity of the government backed by the government's right of 'imminent domain' to enforce humane land ownership policies .
- The government can monitor and control precipitous demographic shifts, if not prevent them, by developing a policy, with international aid, to balance rural and urban economies.
- The safety and well-being of the informal sector depends upon the services of an efficient infrastructure. Only the

government has the resources to maintain effectively the infrastructure in such a fashion as to encourage housing development rather than restrain it.

Healthy Construction Industry:

- A productive building environment requires an efficient manufacturing and supply network to develop the indigenous construction materials at marketable costs.
- Once a building has been constructed, it must be maintained by a support network that insures the distribution of materials and labor at marketable costs.

The previous examples of properly functioning national institutions suggests that, in fact, the diverse opinions put forth by political groups at odds with each other in regard to housing development can be harmonized in unison with the best interests of the nation in mind.

Environmental Constraints

The housing problems of the inhabitants of developing nations are often aggravated by natural causes, in particular, natural disasters and the lack of resources. These problems are deceptive in that developing nations in fact do not have more natural disasters than the rest of the world - nor less natural resources - but suffer from a lack of disaster mitigation and proper management of resources.

Ecological Considerations -

The waste of native natural resources is common practice in most developing nations and was originally encouraged by colonial exploitation. Many developing nations simply served as sources of raw materials that powered the factories of the industrial revolution in Western countries. The inhabitants of the developing nations were encouraged to believe that the resources of their countries were limitless. This attitude coupled with the recent population explosion has led to ecological disasters in regions with delicate ecosystems such as the Sahel region of Africa.

The lack of concern with the ecosystem and with the source of construction materials is evident in most communities of the informal sector both in the rural and urban regions of developing countries. For example, in nations where wood is still the predominant construction material, such as the Dominican Republic, wood is lumbered but not replaced. Nor is wood efficiently used in construction. Wood preservatives are rarely used for construction lumber because of prohibitive costs. A common sight in the Dominican Republic is wooden houses with peeling paint. Most Dominicans cannot afford to paint their houses regularly.

Some options that exist for the Dominicans to preserve their supplies of wood are:

1. Generate a lumber industry that replaces the wood it lumbers.
2. Develop a fast-growing organic alternative such as bamboo.
3. Reduce the amount of lumbering and maximize the efficiency of the lumber industry by - using wood composites such as fiber board or chip board, - concentrating on wood preservation in construction materials and - increasing the production of paint.
4. Decrease the use of wood as a construction material and increase the use of low-cost nonorganic materials such as concrete.

Dominican housing statistics indicate that Dominicans are pursuing the fourth alternative with some interesting results. Many Dominican houses currently built are hybrid wood/concrete .The less visible end-walls are built of concrete block or concrete while the front facades remain wooden.

The lack of regard for the ecosystem in developing countries is also related to the inadequate supply of construction materials and living necessities, such as water and fuel for cooking, which is often wood or a charcoal derivative of wood. Areas within the immediate vicinity of squatting communities in particular are stripped of all available fuel and construction resources, mostly wood, and not replaced.

The consequences of these practices are detrimental to the community. The lack of vegetation causes soil erosion, which can lead to mud slides and flash floods. The stripped areas also become organic waste sites that contaminate the communities' water sources with raw sewage - inevitably causing disease. When the fuel and construction materials eventually run out, members of the community are forced to import fuel and building materials at inflated prices.

In this particular context, the design parameters become

- The need for better supply networks that will not damage the ecosystem within the vicinity of the community.
- Locating the sanitation facilities so as not to contaminate the water supply.

Disaster Mitigation -

Disasters in developing countries often result in staggering casualties. Noted earlier, these casualties primarily occur due to the lack of precautions taken by the inhabitants concerning the location and the structural quality of their dwellings. Communities that are susceptible to disproportionately high casualties in the event of a disaster are those that are

- overcrowded and poorly built
- built in disaster-prone areas such as earthquake zones and flood plains.

In the event of a disaster, many casualties can be traced to flaws in construction details that unskilled builders are unaware of which can be corrected by simple, low-cost design precautions. For example, roofs are commonly blown off in high winds due to poor connections between the roof and the wall. Designers can act to mitigate this problem by devising simple anchoring systems made of bale iron or wire, lashing the rafters to the top-plates. Flying debris from loose roof coverings is also a major cause of injuries. Architects have only to design better anchoring devices to mitigate numerous casualties.

Aesthetic Constraints

In the context of low-cost housing where the primary concern is that of affordability, aesthetics maybe regarded as superfluous:

"The grave danger today is that too many of the architects who work on housing for the poor (moving among them as Florence Nightingale among the wounded) are really a-visual - in some cases belligerently anti-visual rejoicing in acres of ugliness for the goodness of it all..."

Pg. 454, Charles Correa, "Urban Strategies From the Third World", HABITAT INTL, Vol.5, No.3/4, Ed. O.H. Koenigsburger and S.Groak, Pergamon Press, N.Y.C., Co. 1981

The aesthetics that does exist in housing development projects represents that of 'development' and not the native culture or the targeted occupant's identity. 'Development' aesthetic is often borrowed from 'mainstream' architecture and as a result is foreign to native sensibilities. At the

other extreme, the aesthetic becomes one of the 'generic vernacular.' In both cases including aesthetic considerations as an afterthought discourages creative solutions to design problems.

Though the aesthetic is not considered essential in most low-cost housing endeavors it is often unconsciously imposed on the prospective occupants at the expense of their identities. Little credit is given to the native inhabitants' capacity for creating pleasing and valid aesthetic statements. An intimate knowledge of native culture can reveal unique and timeless aesthetic devices.

" Baragan acknowledges his love for and aesthetic debt to the popular ranches, villages and convents. But it should be noted that Mexico's climate and natural resources have always been strong factors in the development of its architecture. The heavy incandescent luminosity of its sun, the strong winds and heavy rains, and the restrictions of poverty and unskilled labor have all contributed to the discipline of structure, simplicity and few materials. "

Pg.106, Emilio Ambasz, THE ARCHITECTURE OF LUIS BARRAGAN, The Museum of Modern Art, New York, 1976

Emilio Ambasz implies that Baragan's keen sense of aesthetic is in fact a well-developed reflection of the common identity of Mexican architecture. In this sense, architects that are not influenced by the strongest aesthetic features of the local culture and environment are destined to produce architecture incompatible to its site.

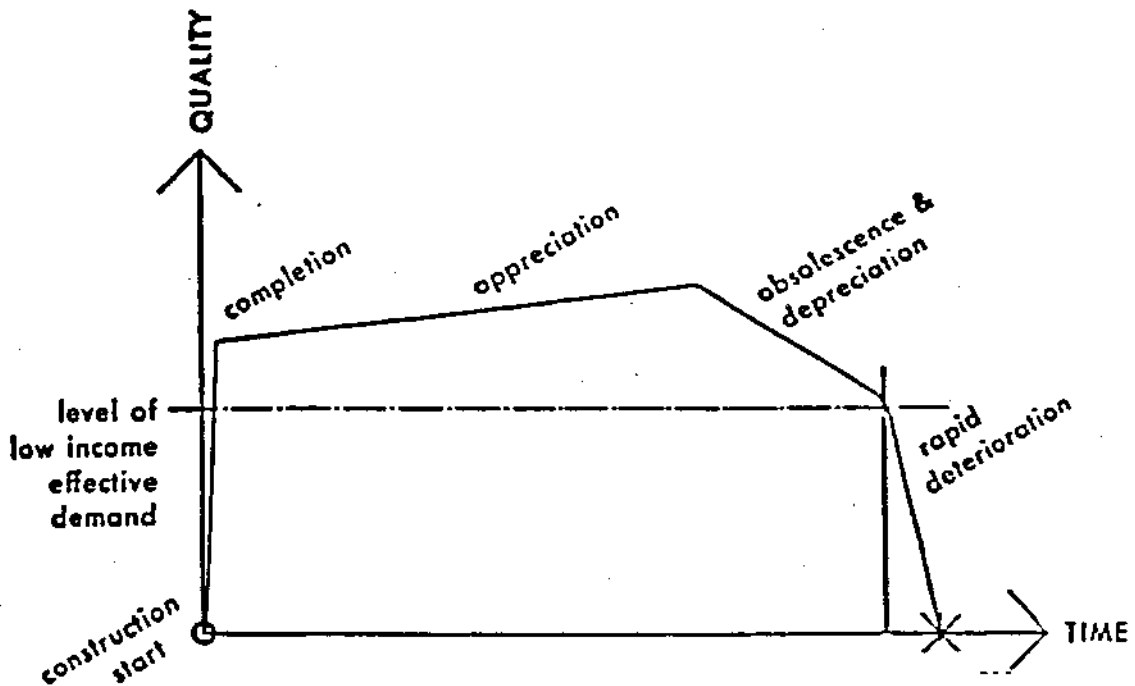

FIGURE 1.1

- Chart showing the appreciation and depreciation curve of a residential building.

Chart adapted from: Pg.227, "The Necessity of for Networks"
 Robert Fichter, John F.C. Turner and
 Peter Grenell
 FREEDOM TO BUILD
 DWELLER CONTROL OF THE HOUSING PROCESS
 Ed. John F.C. Turner, Robert Fichter
 The Macmillan Co., N.Y.C., 1970

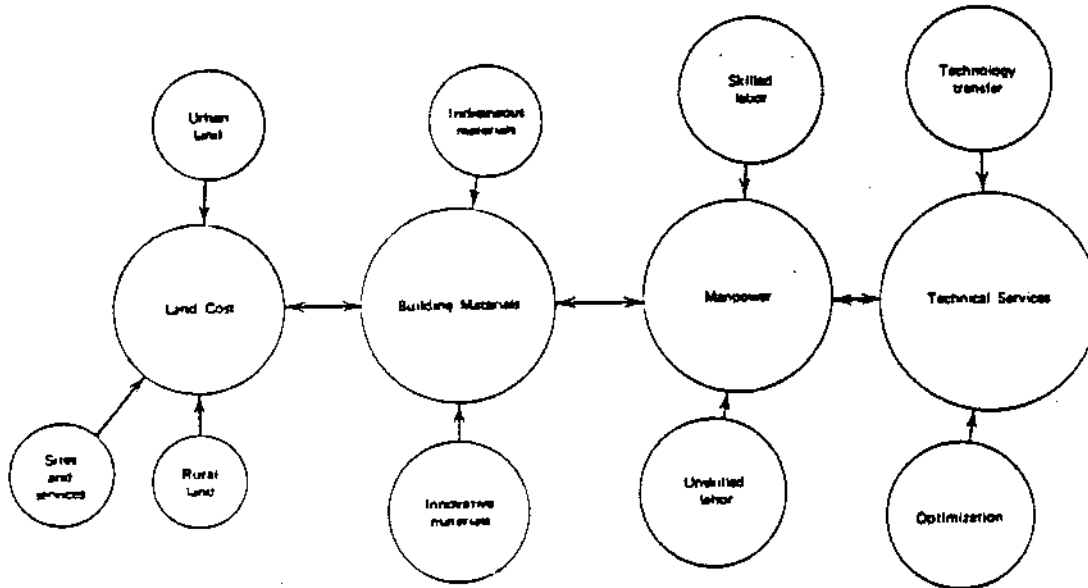

FIGURE 1.2

- Chart showing major cost items in housing construction.

Pg.7, "Lower - Cost Housing: Planning and Implementation"
 Otkay Ural
 CONSTRUCTION OF LOWER - COST HOUSING
 Ed. Otkay Ural, John Wiley & Sons, N.Y.C., 1980

Aid to the third world

FIGURE 1.3

- Chart showing the porportion of aid to the Third World used for the improvement of housing and general living conditions.

"Shelter Fact Sheet"
United Nations Centre for Human Settlements (HABITAT)
P.O.Box 30030, Nairobi, Kenya

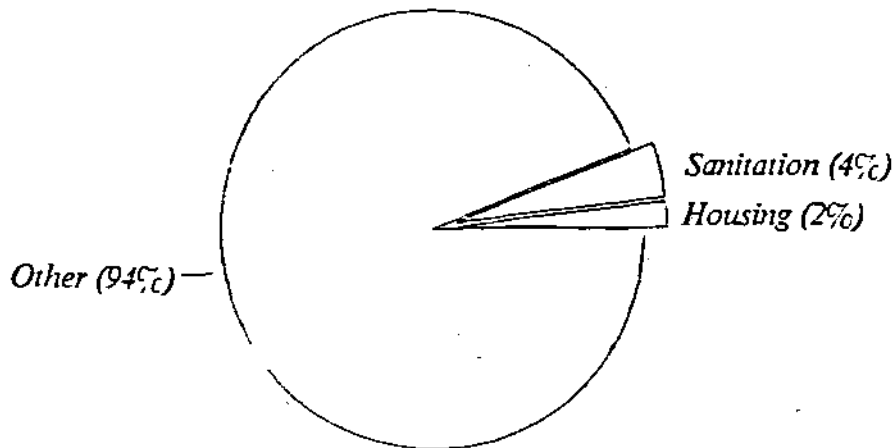
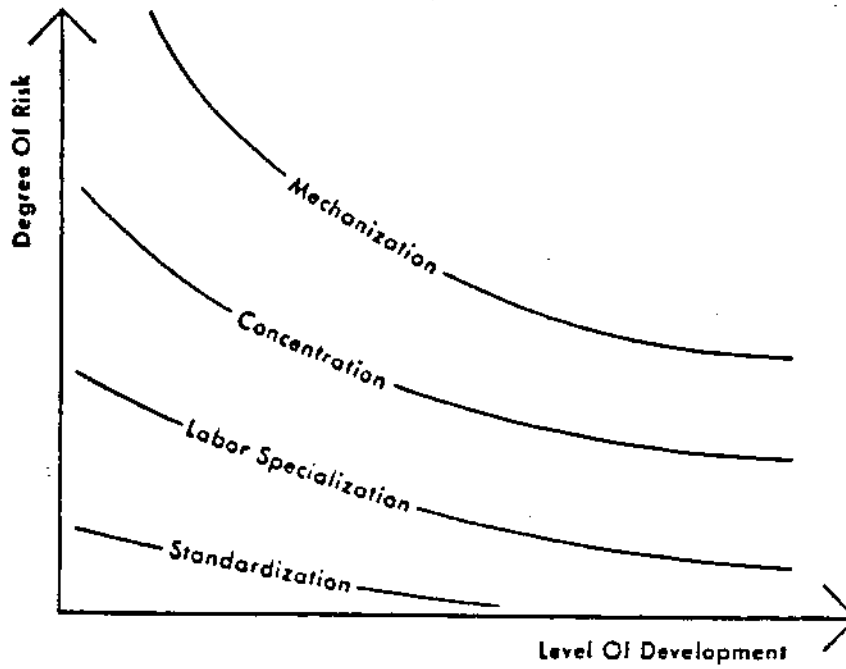

FIGURE 1.4

- Chart showing the relationship between risk and economic development for the four elements of industrialization i.e. standardization, labor specialization, concentration and mechanization.

Pg.221, "Technology and Autonomy", Ian Donald Turner,
 FREEDOM TO BUILD: DWELLERS CONTROL OVER THE HOUSING PROCESS
 Ed. John F.C. Turner and Robert Fichter,
 Macmillan Co., N.Y.C., 1972

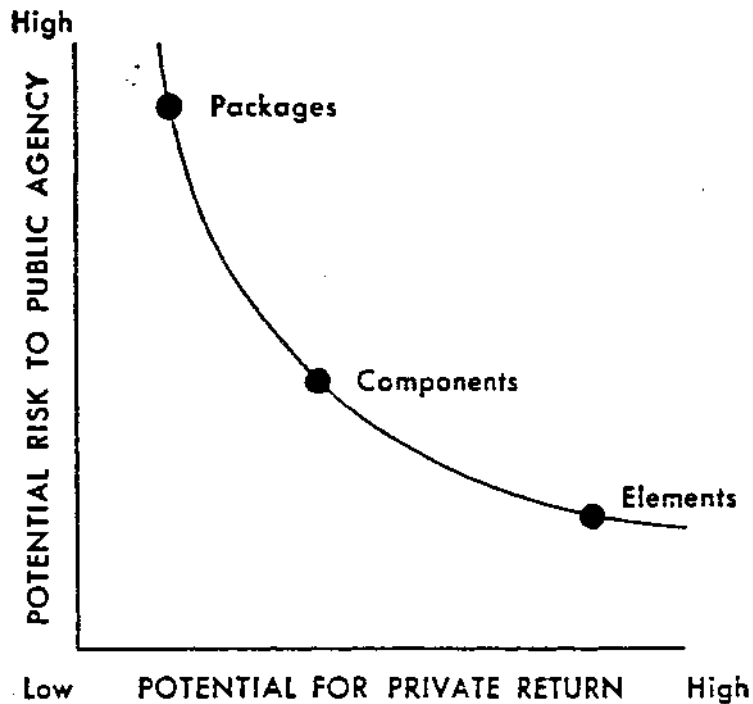

FIGURE 1.5

- Chart showing the potential risk to public agency and potential for private return of building systems requiring packages, components and elements.

Pg.279, "Increasing Housing Autonomy"
 Robert Fichter, John F.C. Turner, Peter Grenell
 FREEDOM TO BUILD: DWELLER CONTROL OF THE HOUSING PROCESS
 Ed. John F.C.Turner and Robert Fichter
 Macmillan Co., N.Y.C.,1972

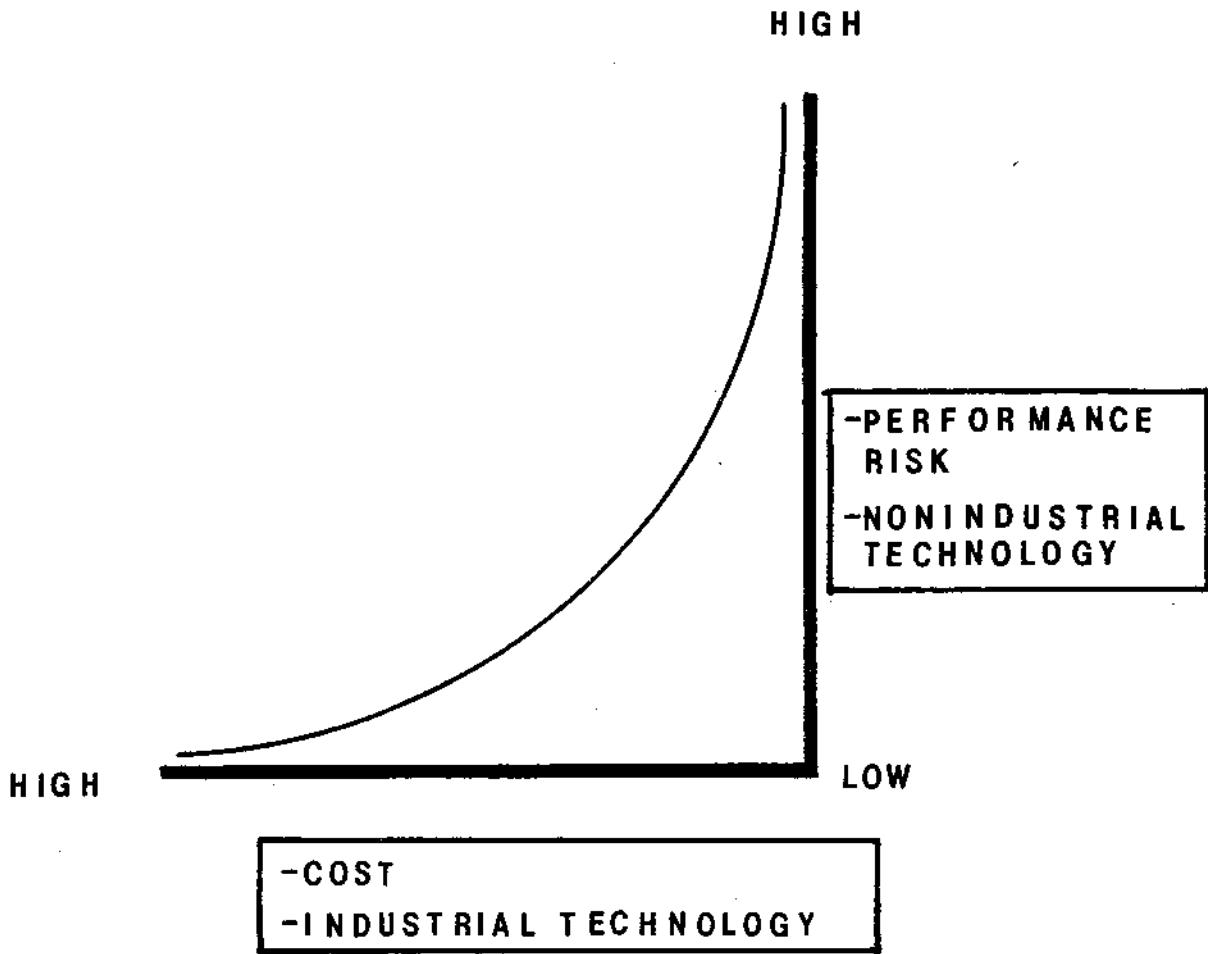

FIGURE 1.6

- Chart showing a curve representing performance risk in relation to nonindustrial technology.

CHAPTER 2 SUMMARY OF DESIGN PARAMETERS FOR DEVELOPING COUNTRIES

To further aid in clarifying an architect's task of understanding the invisible barriers to low-cost housing design in developing countries the previous list of constraints can be focused into a set of design parameters. These parameters should be viewed as design guidelines for low-cost housing in the context of a developing nation. Understanding the subsequent summary of design parameters is therefore a prerequisite to attempting architectural solutions or drawing any conclusions about a low-cost housing design program for developing nations.

Architect/Client Relationship -

Those in need of adequate housing in developing countries cannot afford the personal attention of an architect or most other building professionals such as planners and engineers.

The numbers of those who need adequate housing far exceeds the number of architects and building professionals who can service them.

The first two parameters necessitate that design innovations be replicated within their suitable contexts.

Design Approach -

In order to determine the proper building system for an underdeveloped nation, an architect must assess the social, cultural, economic, political, environmental and aesthetic

implications of his design on the native society.

When designing for a different culture, design decisions carry a different impact. Fundamental architectural concepts of function, aesthetics and value must be redefined.

The appropriate solution for a housing problem in a particular context may not require the services of an architect.

Support Network -

Underdeveloped nations lack a cohesive social, cultural, economic and political fabric. Integrated transnational support networks supplying basic living necessities such as shelter, food, medical aid, education, transportation etc. are either fragile or nonexistent.

Construction development depends entirely upon its social and economic support network. A poorly functioning support network is directly reflected in the construction process.

Fragmented Societies -

Social, cultural, economic and political variations within a developing society are more numerous and dispersed than in a developed society. As a result, the social divisions in a developing nation are smaller and more localized.

In developing countries, the identities and loyalties of the populace are linked with villages, regions, tribes and religions rather than the nation as a whole.

In developing nations rural affiliations of community or religion are extended to the city though an urban lifestyle demands a greater uniformity.

The construction site is a microcosm of its native social unit.

Reducing Risk -

Under the severe economic constraints of the developing world, an architect must ensure that the design project's probability of failure or 'risk' is reduced to a minimum for the intended client/occupant.

'Failure' may entail:

- The project's inability to meet the intended demands i.e. affordable housing.
- The collapse of the project's support mechanisms requiring detrimental design and construction shortcuts as well as cost and time over-runs.
- The abandonment of the project as whole.
- A combination of the previous prospects.

'Failure' also has social implications.

- A housing project that has failed in social respects effects the social fabric of the

community. A failure of this sort involves isolating the occupants from the lifestyle they are familiar with.

Physical failure can be literally interpreted as structural collapse.

Reducing 'risk' requires;

- Appropriate technology for the prevalent construction conditions,
- Cost-effectiveness,
- Meeting the intended occupants' basic needs.

Appropriate Technology -

'Appropriate technology' in this context does not necessarily refer to the use of indigenous construction materials of a particular site or building techniques suited for unskilled labor. The term is intended to describe the use of 'appropriate' materials and technology within the prevalent construction conditions - of which there may be numerous variations.

To reiterate, reducing 'risk' requires the use of 'appropriate' technology in the prevalent construction conditions. In the context of developing and developed nations alike, the use of complex construction requiring sophisticated technology, financing and organization must be proportionate to the native society's capacity to cope with

the complex construction requirements. A gap between the construction project's complexity and the native society's ability to meet the construction demands increase the project's probability of failure.

A project's complexity is related to its'

- logistical requirements,
- 'tolerance' for construction variables,
- scale.

Cost Effectiveness -

Determining the cost effectiveness of a project can be divided into three stages

- before the initiation of the construction process,
- during the actual construction process,
- after the completion of construction.

Before:

The sponsors of the housing project must calculate whether the prospective clients/occupants can viably absorb the incurred debt of the construction costs. An existing tool for calculating the financial feasibility of a project is the 'Bertaud model.'

The construction requirements must match the site's existing capacity for maintaining the logistical necessities of construction.

The demand for housing and the cost of the construction solution must be proportionate. i.e. high demand = low cost

During:

The construction process must entail the minimum amount of wasted materials and labor.

The skills of the construction team must be equal to the construction requirements.

The organizational structure must be adequate to maintain building schedules and supply chains at predetermined cost projections.

After:

The project must meet the occupants' changing needs in order to reduce the rate of the project's depreciation.

The project's maintenance costs must be minimal.

Occupant ownership and maintenance should be encouraged.

Occupants' Needs -

In order to insure that the housing project does not pose a habitable risk to the prospective occupant, the architect must accurately define the occupant's needs. The architect must be able to distinguish between the conventional and possibly inaccurate perception of the occupant's needs and the intended occupant's own perceptions of his living

requirements.

" The problem of housing appears quite different when seen from the national and aggregate level by a public policy maker or a large commercial developer than it does from the perspective of a low-income dweller. At the national level, massive housing deficits are most apparent, and solutions which combine speed, economies of scale and industrialization seem perfectly appropriate from the user's point-of-view, on the other hand, primary considerations are availability (low rent or price level) quality, location in relation to jobs, good schools, transportation, and sufficient control over one's living space to make a personalized home."

Pg.73, "The Housing Problem for Low-Income People", Hans H Harms
FREEDOM TO BUILD: DWELLER CONTROL OF THE HOUSING PROCESS,
Ed. John F.C. Turner and Robert Fichter, Macmillan Co.,
N.Y.C., '72

(Figure 2.1: Priorities for vital needs x income level.)

(Figure 2.2: Priorities for housing needs x income level.)

(Figure 2.3: Matched priorities of occupants'needs.)

Priorities for VITAL NEEDS x Income Level

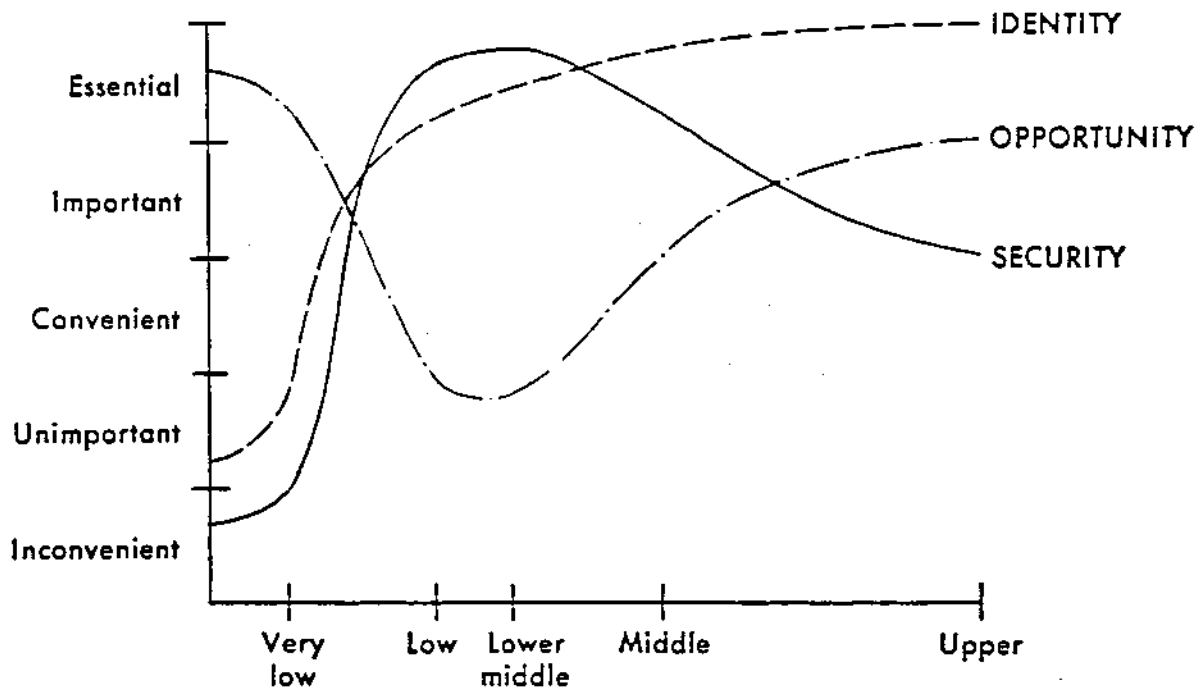

FIGURE 2.1

- Chart showing priorities for vital needs x income level

Pg.165, "Housing as a Verb"

John F.C. Turner

FREEDOM TO BUILD: DWELLER CONTROL OF THE HOUSING PROCESS

Ed. John F.C. Turner and Robert Fichter

Macmillan Co., N.Y.C., 1972

Priorities for HOUSING NEEDS x Income Level

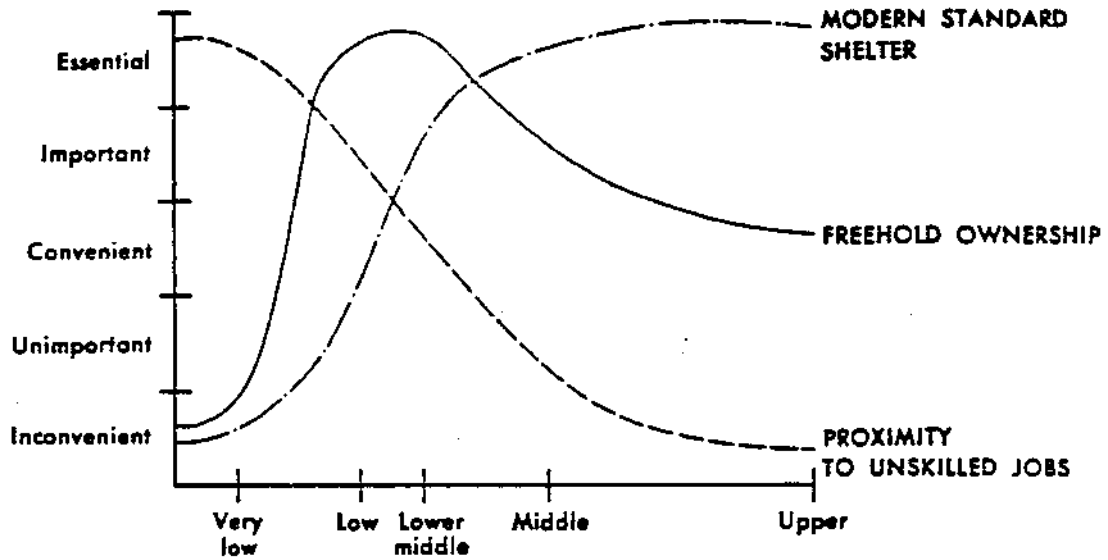

FIGURE 2.2

- Chart showing priorities for housing needs x income level

Pg.166. Ibid.

Matched Priorities

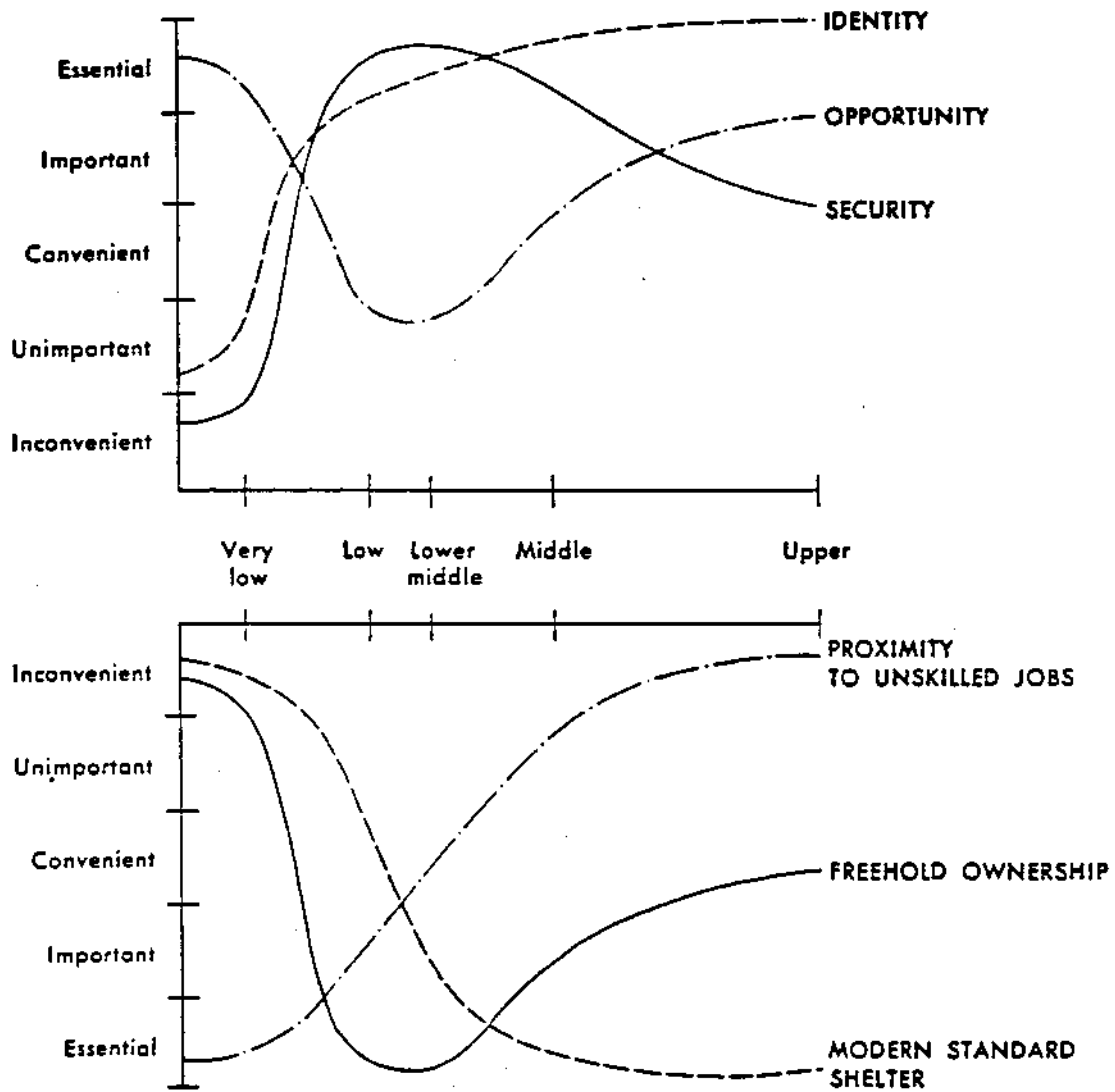

FIGURE 2.3

- Chart showing matched priorities

Pg.167, Ibid.

CHAPTER 3
HOUSING DESIGN FOR DEVELOPING COUNTRIES:
NEW ARCHITECTURAL ROLES, NEW DESIGN APPROACHES
& NEW DESIGN PROCESS

The parameters for architectural design in the developing world illustrate the difficulty of applying the conventional architectural design approach of developed nations - defined generally as, "the planning of buildings and the overseeing of construction" (Webster's Dictionary) or "the art and science of designing and erecting buildings" (The American Heritage Dictionary). Architects involved in the design of low-cost housing for developing nations have had to expand their roles as well as invent new approaches and new strategies to form the basis for understanding the Third World housing problem.

Numerous theories pertaining to particular aspects of development architecture have been put forward by architects, planners and engineers. Some of the better known are Charles Abrams and John F.C. Turner who, with insightful analyses of housing problems in the developing world, helped determine the direction of Third World development policy over the last thirty years. The gulf between theory and reality, however, remains large. The following analysis is an attempt to put the new roles, approaches and strategies of Third World housing development into perspective. The format of this analysis was generated from a process of problem solving in the field of development that currently seems prevalent in implementing

housing development projects.

New Roles

The role of the architect in the context of the developing world is complex. Besides 'planning' and 'overseeing' the architect must apply his design skills to 'improving' and 'facilitating' housing construction.

Facilitating Housing Construction -

Facilitating housing construction may include tasks considered outside those of a traditional architect such as

- financial planning,
- market analysis,
- political management or activism,
- anthropological research,
- new materials technology,
- civil engineering.

The resulting professional hybrids i.e. architecture/economics, architecture/political science, architecture/science etc. become sources of new fields pertinent to the generation and implementation of development policy concerning shelter. Those involved in the hybrid disciplines are often concerned with establishing new construction standards - particularly in the areas of new building codes and zoning laws applicable to the construction environments of developing nations.

The 'hybrid professionals' often de-emphasize conventional design work i.e. plans, sections and elevations, unless such work is for research purposes. The task of 'facilitating' housing construction implies an approach towards design quite different from that of a traditional architect. The facilitator of construction is acting to open the process of building design to the general public whereas the traditional architect regards the process of building design as his exclusive domain.

In the developing world the lack of housing is disproportionately high in comparison to the number of construction professionals available to implement construction and the amount of financial resources to pay the construction professionals for their services is disproportionately low. The traditional values of an architect are therefore rendered dysfunctional. The sheer scale of the housing problem in developing countries suggests that the architect cannot approach the design tasks on a 'per house' basis but must approach the problem from a larger perspective. This larger perspective involves facilitating the process of design in order to induce those who lack the means to afford the services of construction professionals to adequately shelter themselves.

Improving Housing Construction -

'Improving' housing construction implies design is

needed. However, in the context of the developing world where the economic, social and political constraints are severe, the design projects must be cautious and well-defined. Design projects that allow for the greatest amount of tolerance for construction variables and pose the least amount of financial risk are those considered for implementation.

The design demands of developing nations seem modest by the standards of developed countries. For example, typical design concerns usually do not exceed the complexity of

- designing a more efficient truss,
- designing a more versatile shingle,
- designing a better low-cost window and door for tropical climates,
- improving roof ventilation,
- improving roof strength in high wind areas,
- improving wall strength in earthquake zones.

Architectural design for developing nations is often intended for implementation without the presence of an architect to 'oversee' the construction process. As a result, the architect, when designing a low-cost housing project for a developing country, must ensure that the design process is understandable, does not require the interpretation of an architect and that the project is contextually relevant. The affordability of a project is also affected by

the clarity and the appropriateness of the architect's design.

New Approaches

Currently, in order for an architect to design feasibly a humane settlement in the developing world, he must be aware of four convergent strategies of development that clarify the parameters of design :

1. The demystification of design
2. Contextualism.
3. Affordability.
4. The dissemination of information.

The Demystification of Design -

Two design parameters in developing countries that shape an architect's task in designing adequate housing are:

- Those in need of adequate housing in developing countries cannot afford the personal attention of an architect or most other building professionals such as engineers or contractors.

- The numbers of those who need adequate housing far exceeds the number of architects and building professionals who can service them.

As a result of these parameters architects are in the position of having to fulfill the housing needs of more people for less cost. Until recently, designing for the 'masses' has produced convenient generic 'mass' housing.

Architects designed large apartment blocks which in the short run met their low-cost housing objectives by swallowing a large amount of people utilizing the minimum amount of space and materials. The statistics did not account for the negative long term affects of the living conditions which severely detracted from the occupants' established living patterns.

Currently, architects in the field of Third World housing development are realizing that the lack of personal contact with the multitude of inadequately sheltered people does not justify depersonalized design. Architects are no longer thinking in terms of designing huge housing projects for the poorly sheltered masses but are thinking in terms of generating incentive among the inadequately housed inhabitants of developing countries to shelter themselves.

John F.C. Turner is generally credited with initiating this new approach towards low-cost housing. His approach is summarized in 'Turner's First Law of Housing':

" When dwellers control the major decisions and are free to make their own contribution to the design, construction and management of their housing, both the process and the environment produced stimulate the individual and social well-being. When people have no control over, nor responsibility for key decisions in the housing process, on the other hand, dwelling environments may instead become a barrier to personal fulfillment and a burden on the economy." Pg.xxxiii, Colin Ward in the preface to John F.C. Turner's HOUSING BY PEOPLE - TOWARDS AUTONOMY IN BUILDING ENVIRONMENTS, Pantheon Books, New York, 1976

(Figure 3.1: Percentage of those who build their own homes in four cities of developing countries.)

With this new direction in thought, architects are currently grappling with means of making design and construction skills more accessible to those in need of them. This process of countering architectural exclusivity can otherwise be known as 'design demystification.'

Architect Christopher Alexander has devoted much of his career attempting to formulate a 'pattern language' that defines this demystification process. Alexander suggests that a pattern of events related to space exists. This pattern of events can be translated into an architectural language that can be understood by amateur designers and builders. Alexander envisions the design process as highly organic and uses the analogy of a flower's growth to depict a 'natural' construction process.

"If you want to make a living flower, you don't build it physically, with tweezers cell by cell. You grow it from the seed.

This hinges on a simple scientific proposition: The complexity of an organic system, which is essential to its life, cannot be created from above directly; it can only be generated indirectly.

This cannot happen unless each part is at least partly autonomous, so that it can adapt to the local conditions in the whole.

A building which is natural requires the same."

Pg.162, Christopher Alexander, THE TIMELESS WAY OF BUILDING
Oxford City Press, New York, 1979

In this organic growth an order does exist. Alexander attributes this order to a genetic code that gives the

flower its shape and identity. It occurred to Alexander that this genetic code for building might be lodged in the human mind as well.

"Autonomous creation of the parts, if taken by itself, will produce chaos.

What makes a flower whole, at the same time that its cells are more or less autonomous, is the genetic code, which guides the process of individual parts and makes a whole of them."

And just as a flower needs a genetic code to keep the wholeness of parts, so do the building and the town.

So I began to wonder if there was a code, like the genetic code, for human acts of building?

Is there a fluid code, which generates the quality without a name in buildings, and makes things live? Is there some process which takes place inside a person's mind, when he allows himself to generate a building or a place which is alive? And is there indeed a process which is so simple too, that all people of society can use it, and so generate not only individual buildings, but whole neighborhoods and towns?

Pg.166, Ibid.

Alexander suggests that a demystified process of architectural design does exist among vernacular builders who design and build according to common construction practices described simply as 'rules of thumb.' Alexander examines these vernacular construction practices with an analogy involving the erection of a barn.

"The people can shape buildings for themselves, and have done it for centuries, by using languages which I call pattern languages. A pattern language gives each person who uses it, the power to create an infinite variety of new and unique buildings, just as his ordinary language gives him power to create an infinite variety of sentences.

At first sight, we might imagine that each farmer made his barn beautiful, simply by paying attention to its function.

But that does not explain the similarity of different barns. If every new barn were created from scratch, purely from the functional nature of the problem, we should expect to see a much greater variety of forms than actually exists.

We might imagine then, that the farmer got his power to build by copying other barns around them.

But this does not explain the great variety of barns. And it does not explain the enormous variations which the farmer is able to make, in his own barn, without going wrong.

The proper answer to the question, "How is a farmer able to make a new barn?" lies in the fact that every barn is made of patterns.

These patterns are expressed as rules of thumb, which any farmer can combine and re-combine to make an infinite variety of unique barns." Pg.167, Ibid.

Rules of thumb are in fact a demystified construction pattern language that are contextually relevant. Alexander goes on to examine whether in fact these 'pattern languages' of vernacular builders are related to a universal genetic code for building.

"To understand, in detail, how these patterns work, we must extend our definition of 'a pattern'.

Each pattern is a rule which describes what you have to do to generate the entity which it defines.

It is in this sense that the system of patterns form a language.

A pattern language is a system which allows its users to create an infinite variety of those three dimensional combinations of patterns which we call buildings, gardens and towns.

These pattern languages are not confined to villages and farm society. All acts of building are governed by a pattern language of some sort, and the patterns in the world are there, entirely because they are created by the languages people use."

Pg.176-193, Ibid.

The universality of this pattern language is debatable. However, the fact remains that a wealth of design knowledge concerning 'rules of thumb' exists and is often ignored in favor of design conventions in mainstream architecture. These design conventions of mainstream architecture can be unnatural and often inapplicable in developing countries where the inhabitant's pattern of life is intimately related with the immediate context. Highly personalized living conditions are quite fragile and threatened by sudden changes - especially in developing nations where the slightest shift in one's lifestyle can mean the difference between poverty and security.

In short, design demystification can be viewed as a variation of the traditional standardization process. Standardization requires that all construction products fall within a replicated pattern of manufacturing and erection to facilitate distribution and the implementation of safety standards, in turn making construction products more accessible to amateur builders. The design demystification process is a deliberate means by which the architect personalizes universal construction rules of building technology to achieve the same ends of accessibility to the nonprofessional home-builder.

In conclusion, though the concepts behind design demystification and standardization vary, the ends are alike

in creating a 'duality' between the two systems of development which complement each other. Design demystification produces more variations to suit the various contextual nuances of the site whereas standardization generates uniformity conducive to the integration and growth of the construction market.

Contextual Design -

Witold Rybczynski and his co-authors aptly demonstrate in their book HOW THE OTHER HALF BUILDS that before a design project for a developing country can be considered, the site's contextual features must be closely examined. Rybczynski divides his examination of four slums in the city of Indore in India, Kulkari Ka Bhatta, North Toda, Firoz Gandhi Nagar and Adarsh Bijasan Nagar into two parts, 'Space' and 'Plots'. 'Space' is further subdivided into chapters describing;

1. HOUSE EXTENSIONS
2. WORKPLACES
3. SMALL SHOPS
4. TREES
5. PUBLIC STRUCTURES
6. VEHICLES
7. ACCESS STREETS

The surveys of these aspects of Indore's slums are painstakingly detailed - even measuring human dimensions at

various tasks. However, Rybczynski states that these data are necessary in order to produce a more contextually appropriate set of construction standards.

"Existing informal sector housing, often termed slums, represents a solution rather than a problem. It is moreover, a solution that appears to deny conventional planning orthodoxy. The priorities of the slum-dweller are frequently not those of the municipal authorities. Space takes precedence over permanence. A porch may be built before a bathroom; a work place may be more important than a private bedroom. The apparent aversion of values is especially evident in the public spaces. Whereas planned sites and services projects usually incorporate rudimentary, minimal circulation spaces, the public areas of slums are characterized by richness and diversity.

There is nothing basic about "basic housing" -- an inaccurate and misleading term. Architects and planners are only beginning to understand the complexity of the housing requirements for the poor. Present - day "standards" are a poor tool indeed in this process. They reflect a view of optimal solutions that is not only culturally inappropriate but also inadequate. A new set of settlement standards needs to be evolved. These standards should seek to accommodate, rather than to reorganize. They should reflect the (sometimes harsh) reality of the urban poor, and they should respond to their special needs, not an idealized set of criteria."

Pg.1, HOW THE OTHER HALF BUILDS, Vol.1
 Witold Rybczynski, Vikram Bhatt, Mohammed Alghamdi, Ali Bahammam, Marcia Niskier, Bhushan Pathare, Amirali Pirani, Rajinder Puri, Nitin Raje, Patrick Reid
 Center for Minimum Cost Housing, McGill University, Montreal
 Research Paper No.9 December 1984

(Figures 3.2 & 3.3: Washplace Study & Human Dimensions)

The second part of Rybczynski's study, HOW THE OTHER HALF BUILDS, is an attempt to derive statistical characteristics for plots that can be used for construction. To attain this information Rybczynski analyzes the existing plots in relation to the following survey :

"- Built plot area is determined by multiplying plot frontage by plot depth.

- Plot space availability is determined by dividing built plot area by the number of inhabitants.

- Built plot ratio is determined by dividing built plot depth by built plot frontage.

- Plot frontage is determined by measuring that side of the plot that fronts on the main access street.

- Plot exposure is determined by counting the number of sides of the built plot that are contiguous to public open space. "

Pg.2, HOW THE OTHER HALF BUILDS, Vol.2

Carlos Barquin, Richard Brook, Rajinder Puri, Witold Rybczynski
Center for Minimal Cost Housing, School of Architecture,
Mcgill

University, Research Paper No.10, June 1986

Rybczynski's conclusions indicate some interesting correlations that may be applicable to other such slums.

" - There is a strong correlation between family income and area for single family plots, and none between multi-family plot areas and family incomes. This suggests either that as families become better off they move to larger, individual plots, or that wealthier families acquire larger plots of their own; why this should be more so for single-family plots is unclear. In any case, it appears that when families share a plot, its size is determined by things other than family income. The correlation between family income and the number of persons in the family is strong for both single- and multi-family plots --obviously larger families have more wage earners.

- There is no correlation between family income and any other of the physical plot characteristics -- space, ratio, frontage or exposure -- for either type or plot. The variety of plot shapes, sizes and exposures appears to be unrelated to differences in family income, despite the fact that the latter are considerable."

Pg.33, HOW THE OTHER HALF BUILDS, Vol. 2, (Ibid.)

Though these observations can be considered universally applicable, the validity of the correlations can only be

tested by carrying on similar research in a completely different context. The implication of this research is that before a feasible housing project can be undertaken the target 'slum' or community must be similarly surveyed in order to obtain accurate construction information. Architects and planners faced with the prospect of 'upgrading' communities rather than beginning with a virgin site must be particularly careful to understand the context of the intended projects. Understanding the context may mean resorting to the traditional architectural technique of producing measured drawings for the entire area being considered for development. In any case, Rybcznski implies that a total immersion of the architect in the context of the building site is necessary before the architect can presume to generate any meaningful design solutions.

As in the case with the design demystification/standardization duality, the contextual approach can be divided into two alternative means for achieving the same ends of low-cost housing development.

An alternative to the holistic approach of Rybcznski, particularly if an architect has less access to a site and its environs than did Rybcznski, is the approach of 'detail development'. Aspects of building in a particular context that present insoluble problems for native builders are isolated and examined in detail. Again this approach requires sufficient knowledge of the building environment to

know what the problems are . However, information of this sort is usually available second-hand through case studies of actual building projects in developing countries. Areas of particular interest have been roofs, because of the difficulty of erecting low-cost roofs - and material research, because of the need for low-cost indigenous materials. In addition to these to areas of research, there are numerous fields of this nature that have involved specialized research and interdisciplinary knowledge on the part of the architect.

Affordability -

The Bertaud model, unlike HOW THE OTHER HALF BUILDS, is explicitly intended as a tool for development . The model operates according to parameters involving 'affordability' as opposed to Rybcznski's emphasis on 'context.' Bertaud's model specifically addresses the following problems;

"AFFORDABILITY - How much can specific types of low-income households afford to pay for shelter, given their present and foreseeable incomes and specified conditions under which that shelter can be financed?

FINANCIAL TERMS - How much will the amounts they can afford to be changed if the interest rates, recovery periods or down payments are changed? Or if graduated monthly payments are introduced to reflect expected increases in incomes? If subsidies are introduced?

PROJECT FUNDING - What will be the annual capital contributions required of the government agencies involved in order to sustain project implementation with different types of shelter solutions and/or with different levels of subsidies?

PLOT & HOUSING DESIGNS - What are the physical shelter options available to specific types of households within the expenditures they can afford? What plot sizes are feasible? What densities are implied? What types and standards of infrastructure, community facilities and housing are feasible? What locations are feasible for projects, given specified constraints on the land prices? To what degree do individual project features have to be sacrificed in order to achieve improvements in other features and still maintain affordability? (For example, how much do plot sizes have to be reduced in order to incorporate higher standards of infrastructure or, as the obverse of this, how much do infrastructure standards have to be reduced in order to achieve larger plots? To what extent do housing types have to be simplified and these or other costs reduced in order to achieve a preferred location on higher - priced land?)

COST RECOVERY & PROJECT DESIGN - What mix of household types and shelter solutions can be incorporated in a project and still achieve affordability and cost recovery for the project as a whole?

SITE SELECTION - Given the land prices and off-site infrastructure costs associated with the various sites which are potentially available, which sites can be considered for projects of particular types (with particular mixes of low-income households, particular types of shelter solutions and particular types of standards for community facilities)?"

Eg.3, THE BERTAUD MODEL, A MODEL FOR THE ANALYSIS OF ALTERNATIVES FOR LOW-INCOME SHELTER IN THE DEVELOPING WORLD
Prepared by PADCO, Inc., in collaboration with World Bank staff
Urban Development Department, Technical Paper No.2
World Bank / December 1981

The Bertaud model can be viewed as a system of compensations . The emphasis becomes one of creating the maximum number of design and planning options out of the minimum amount of resources. The design/planning options are compensated for by financial adjustments elsewhere in the design process to prevent cost over-runs. For example, a larger plot must be compensated for by a smaller street. An increase of infrastructural services might mean cheaper

materials used for the construction of the house and so on...

In the last analysis, the Bertaud model provides a form of home - buyer's protection. The cost ceiling that the prospective home-owner puts on the construction of his house is not violated. The affordability of the house is calculated exclusively according to the occupant's solvency.

Nevertheless, the Bertaud model cannot be construed as a design or planning solution in itself. The architect or planner in conjunction with the client or in the client's best interests must make the crucial decisions about where the compensations must occur. The Bertaud model is also only as accurate as the data it utilizes. In this sense, the financial data of the intended occupant must be complete and accurate. The applicability of the Bertaud model also depends on the long-term replication of the client's financial resources. Those people without a steady, predictable source of income are less likely to achieve a satisfactory housing solution through the application of the Bertaud model.

Affordability is the initial concern of most building projects in the developing world. As a result, questions related to affordability often take precedence over other concerns in the design process. Once the architect is reasonably certain he can mobilize the funds for a new project, all the other phases of the design and construction

process can be implemented. This is not to say that affordability is the most important concern in the design process even in developing nations. However, the limitations set by the initial financial constraints form the most tangible design parameter.

Dissemination of Information -

In developing nations, the designer of low-cost housing is not approached by his clientele. The architect must assume the responsibility of disseminating design information. The dissemination of information has a two-fold purpose:

1. To relay pertinent design information to those who need it.
2. To test the validity of design innovations before they are implemented by gauging the related feed-back from prospective users.

Currently, improving the means of communication between those who lack adequate housing in developing countries and architects from around the world concerned with low-cost housing innovations is considered a priority among international organizations and national organizations alike, ranging from the United Nations' housing organization, HABITAT, to non-governmental national organizations such as CII-VIVIENDAS of the Dominican Republic.

The emphasis of international and national housing organizations on improving information dissemination is in concurrence with John F.C. Turner's first two proposals of four proposals in his book, HOUSING BY PEOPLE.

Proposal One: Analysis -

" The first and most important proposal is to increase communication between people in action. All over the world there are many people practicing these principles - in fact there are millions who are exercising their freedom to build and there are vast areas of housing by people. Among them are many who see far beyond the obvious facts and immediate potential - especially those who have come up against the often disastrous public and private corporate action of ordinary people. They have therefore come to question the principles on which heteronomous (top-down or centrally administered) housing is based. And a rapidly increasing number are preparing or already carrying out radical alternatives. No single activity can be more important than encouraging these pioneers. Increased inter-communication will not only help the redoubling of their current efforts but will greatly increase the chances of gaining support from currently inactive people who want to work in these ways. Material and administrative support is already coming from an increased number of public and private, national and international agencies who are seeking to restructure their policies.

PROPOSAL ONE is to set up an international communications network in order to intensify the use of existing channels of communication (both formal and informal) in ways that increase universal access and reduce the risk of exploitation by entraining powers.

Proposal Two: Analysis -

By far the greatest need and the most frustrated demand is for case studies and materials. Data banks tend to be counter-productive, partly because they are indiscriminating and fail to distinguish data from information so that the user is overwhelmed with facts that obscure as much as illuminate. Furthermore, data banks are technologically opaque to all but the experts, most of whom are employed by agencies that flout all the principles the network supports.

PROPOSAL TWO, therefore, is to set up a number of centres where case materials will be collected, indexed and made available to those needing access to precedents set. All such centres will be interconnected so that anyone can search the rest for particular documents or topics."

Pg.163 - 164, John F.C. Turner
HOUSING BY PEOPLE - TOWARDS AUTONOMY IN BUILDING ENVIRONMENTS, Pantheon Books, New York, 1976.

The architect in the United States has quite a few avenues of communication he can choose from to disseminate information to developing nations in a variety of ways ranging from business propositions to research data. There are also numerous sources of accurate and current information concerning housing development in developing countries in English, from case studies of actual projects, to general topics concerning policy. The organizations that make development information available to American architects represent a wide spectrum of interests. Large organizations such as the World Bank and the Agency for International Development emphasize large scale business ventures between developing and developed nations. Other organizations such as the International Council for Building Research, Studies and Information (CIB) exist exclusively as repositories of research information. Certain organizations such as Appropriate Technology International remain oriented towards the development of one technology.

What remains unconfirmed is whether this transfer of information benefits the actual users, how soon the

information reaches the users, whether the information actually reaches the users at all, and finally whether the users receive distorted or accurate information.

By the same token, despite the abundance of data concerning low-cost housing for developing nations, common sources for this material are difficult to find. The architect intending to obtain information on a particular aspect of low-cost housing construction and design will discover that the material varies with the organizations. In the area of development studies there are no information hubs that serve effectively as comprehensive repositories of information as would, for example, the American Institute of Architects for general architectural information. The various organizations carry their own collections of publications, journals and periodicals, many of which involve information that is highly specialized or focuses on particular case studies. Though publications on development policy exists, development policy is currently in a state of fluctuation reflecting the uneasy state of the global economy, partially induced by unresolved debts and trade imbalances between the developed and developing nations.

In spite of these variables, the architect has three options he can choose from in order to gain access to inhabitants of developing countries in need of low-cost housing aid.:

- To actively participate in the dissemination process by visiting the developing nation and its' particular housing sites in question and working with active native housing organizations such as CII-VIVIENDAS/CETAVIP in the Dominican Republic;

- To contribute to the existing pool of research concerning design, construction and material innovations that are appropriate to building conditions in developing nations and can be implemented by non-governmental organizations or national organizations as they see fit;

- To 'demystify' the design process in manuals, comics, posters or publications that are conducive to

- . simple comprehension,
- . minimum translation,
- . low-cost distribution.

These documents can be distributed in turn by housing organizations within the intended context of the design innovation. (Figure 3.4 : Comic)

As with affordability the dissemination of information is a straightforward phase of the design process with no dualities. How operable the architect's lines of communication are with his source of design information is also a tangible part of the design process - particularly before initiating the 'act' of design when the validity of an architect's concepts must be tested.

At this point, a pattern of design strategies hinting at an overall design process is discernible.

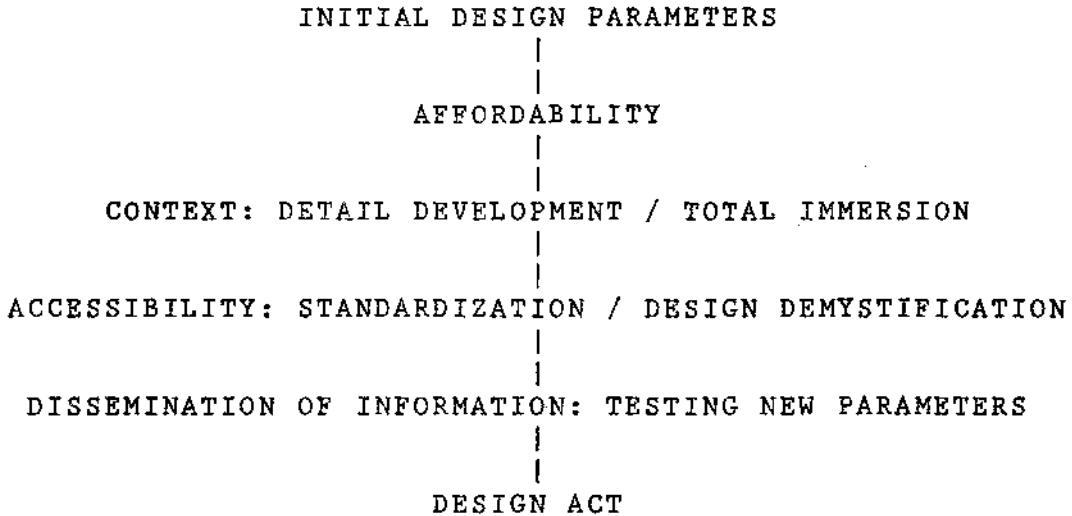

New Process

To better understand the process of design required for housing construction in developing nations, the aforementioned design approaches must be analyzed in conjunction with the new roles of architects.

To reiterate, two new roles architects have adopted, in addition to the original tasks of planning buildings and overseeing construction, are facilitating and improving design and construction.

Passive Design Approach -

The facilitator can be characterized as an adherent of a 'passive' design approach which entails improving the process of design and construction to make the task of

building structures more accessible to the amateur home-builder. The scope and complexity of improving the design process discourages designing at the intimate level, i.e. a house to house basis. The goal of the facilitator is to form the foundation of a standardization process which will make the construction environment more amenable to the potential builder who has no special knowledge or skills related to design and construction.

The passive design approach can be divided into three stages:

- Context: Detail development
- New technology, building codes and zoning laws
- Standardization

Context: Detail Development -

Detail development describes the act of isolating a certain aspect of construction in a particular context for further study. Isolating building problems of genuine concern to native builders in developing countries requires a thorough knowledge of the constraints they face in their construction environment. The architect must therefore be familiar with the context of the targeted site. For example, an architect may experiment with new building materials indigenous to the site with the purpose of creating an affordable building system for local inhabitants. This experimentation may require a knowledge of materials not

commonly associated with an architectural education .

New Technology, Building Codes and Zoning Laws -

This stage describes the process of preparing new technologies and design innovations for utilization. New technology must be tested for performance standards just as design innovations must be monitored through effective and appropriate zoning laws and building codes.

To use the previous example, a new building material must be tested for structural and climatic performance. Information on this material's use must be complete in order to prevent its incorrect application. Design innovations should not either endanger the lives of the prospective inhabitants or cause them discomfort.

Standardization -

Standardization in this case refers to the act of utilizing new technologies, building codes and zoning laws. Standardization as mentioned in Chapter One, "Constraints", is a process of checks and balances enacted to regulate the building industry. This is a long-term process and requires the cooperation of all the nations' building institutions.

Continuing the example of the new material, an architect must assess what standard of performance is allowable and what dimensions are nationally accepted, especially if the material is to be mass produced and marketed as a specific construction element or component.

In relation to the entire design process the 'passive' approach can be visualized thus:

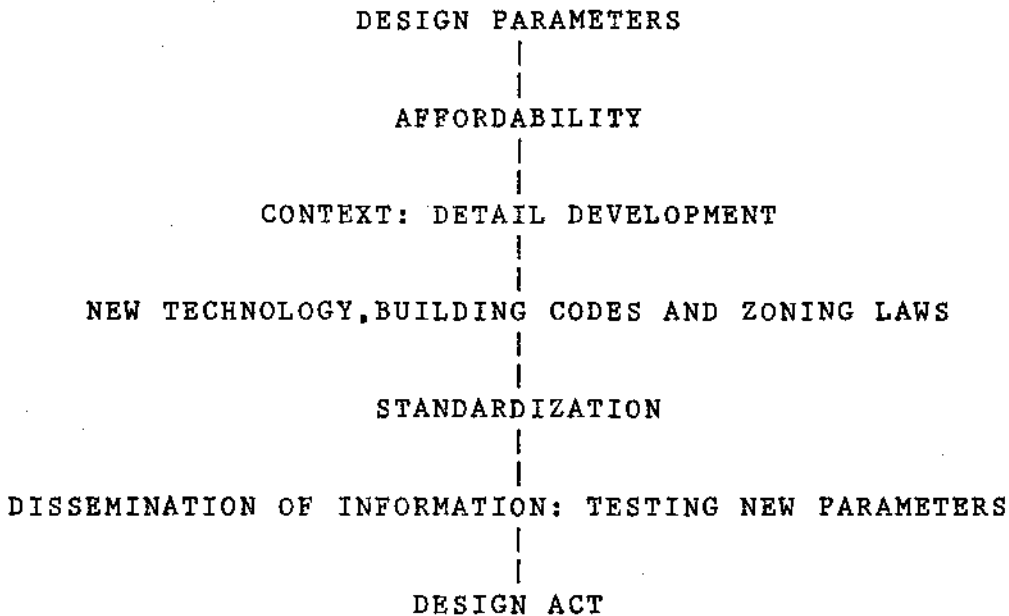

Large Ordering Sites and Services Settlements: A Large Scale Example of 'Passive' Design -

Current experimentation with large ordering sites and services settlements affiliated with the World Bank reflects a passive form of large scale housing development.

The infrastructure is constructed as a framework for regulated growth as with conventional sites and services projects. However, the large ordering system permits a more natural and organic development process. Conventional sites and services projects are organized around specific plot dimensions and plot arrangements usually in the form of a grid. Growth is restricted and orderly.

As the label " large ordering " implies, community growth in a large ordering system is patterned according to the geographical and social features of the specified area at large as opposed to the restrictive multiplication of rectangular plots. The infrastructure is integrated into the natural growth pattern of the community. The infrastructure rather than confining growth to a grid - like plan , induces growth along the pre - determined path of natural expansion. The resultant plots are shaped according to the needs and means of the inhabitants.

(Figure 3.5: Sites & Services: Example of plot development.)

Active Design Approach -

The active design approach requires that the building technology or design methodology of low-cost housing construction be improved, not simply made more accessible to the nonprofessional builder. Improving the construction process, however, requires actual design input. Housing design for developing nations out of necessity must be cautious and incremental. Design improvements usually involve purely technical innovations emphasizing affordability and structural durability. Active design requires a particular set of design parameters and therefore progresses through a series of stages different from that of the passive design approach. The stages are:

- Context: Total Immersion
- Design Analysis
- Design Demystification

Context: Total Immersion -

In order to actively improve design standards in a developing country the architect must have thorough knowledge of the site and its contextual features. In reality, the term 'developing country' is loosely applied to a patchwork of dissimilar societies that are alike in that they suffer similar social and economic afflictions. The general problems of overpopulation, poverty and fragmented societies grow from particular regional, economic and social facets that are unique within their contextual frameworks.

Residential architecture also is an intimate form of technology in that it concerns the personal lifestyles of the inhabitants. As a result, the architect must be closely in touch with the prospective occupants' needs.

An intimate understanding of a society and its building patterns requires total immersion in its environment. Comprehensive knowledge of this kind is gained only by actually living in the country the architect intends to design for. The architect will be able to use the more conventional design approaches i.e. floor plans, elevations etc. , only if he is familiar with the day-to-day living experiences of the prospective occupants of his buildings.

Design Analysis -

Once the architect has become acquainted with the site and its context, he can tentatively begin analyzing design requirements to meet the local needs for shelter. Residential design in the context of most developing nations must be cautious and piece-meal so as to avoid damaging the fragile lifestyles of the poorer inhabitants of developing countries.

As in the case of passive design, architects cannot cost-effectively concentrate on designing one house at a time in developing countries. The poor inhabitants in need of housing cannot afford to pay for the services of an architect and there are not enough architects in the developing nations to fill the needs of all those in need of adequate shelter, therefore, designs must be replicable. Design innovations usually involve improving or simplifying construction technology - to reduce cost, mitigate structural dangers and eliminate climatic hardships for the occupants.

A common design concern in many developing countries is roof construction. The tropical climate of many developing countries emphasizes design problems related to ventilation, water repellence, infestation and wind resistance, i.e. hurricanes and typhoons. Successfully reproducing such design innovations depends primarily on the prospective builder's ability to understand the

improvements and his willingness to implement them.

Design Demystification -

Producing reproducible designs in a nonstandardized society is a difficult achievement. However, an alternative to standardizing a nation's construction process exists. The architect can demystify the design process by making important architectural knowledge accessible to prospective amateur builders. The demystification of the design process involves two steps:

1. Defining the Prevalent Construction Patterns in a Particular Setting -

A society's building customs are influenced by living habits on one end of the spectrum of design generators and by purely environmental considerations at the other. The architect's task involves discovering the design generators particular to the targeted society and defining them in terms of identifiable patterns. Developing design topologies of local housing trends aids in understanding the prevalent design generators. Vernacular architecture is strongly indicative of design generators.

2. Integrating Contextual Design Patterns With Universal Construction Rules-of-Thumb -

There are universal rules of construction that have developed over generations of construction experience to

improve building technology regardless of the context. Combined with an understanding of the contextual design patterns, an architect can direct design innovations towards a particular user group.

For example, rural inhabitants of the coastal regions of the Dominican Republic, Haiti, Barbados, Jamaica etc. may be more concerned about anchoring systems for roofs because of the seasonal hurricanes. Residents of Mexico City are currently rebuilding to mitigate against earthquake disaster. The crowded urban inhabitants of Indian cities require design expertise in circulation and sanitation. The architect will find that the needs of these particular groups overlap. However, in order to proceed to the subsequent step of the design demystification process i.e. information dissemination, the user group must be clearly identified.

A visual representation of the 'active' approach can be seen as a reflection of the 'passive' approach achieving the same ends through different means.

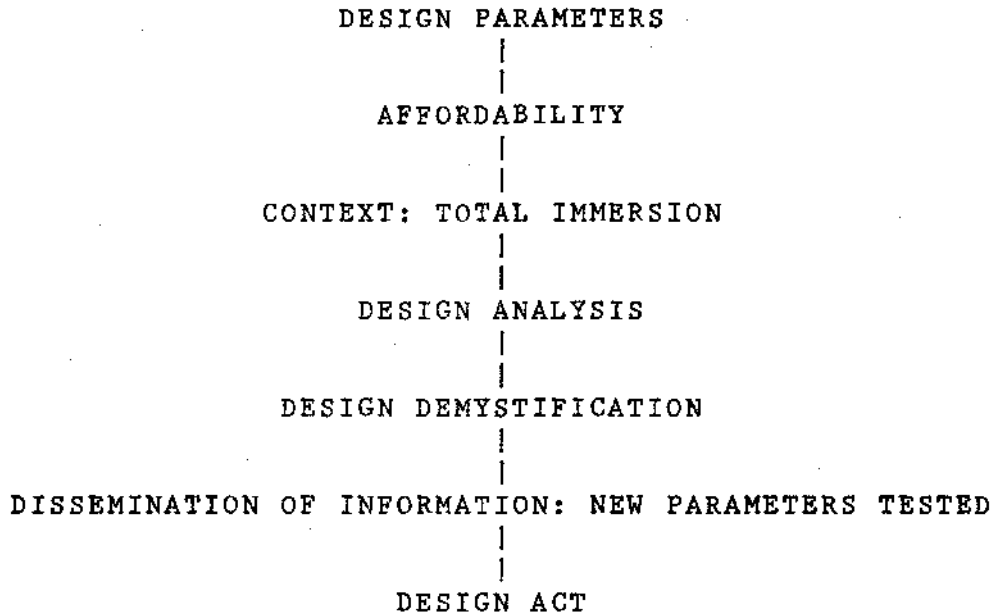

Laurie Baker: Sketch of an 'Active' Designer -

In many cases too numerous to mention attempts of educated professionals to actively design and build housing for the poor in developing countries have failed. The architect involved in low-cost housing often must battle public opinion from the government bureaucracies of the native countries down to the prospective occupants who have much to gain from design innovations.

This is not simply a problem of uninformed architects from the developed nations trying to make an impact in the foreign environments of developing countries - but a problem of native Third World architects as well, who are well acquainted with domestic living and construction habits. A case in point is Egyptian architect Hassan Fathy's

'architecture for the poor' which inspite of its imaginative low-cost use of traditional materials and building techniques and sensitive design in response to Egyptian living patterns, was often rejected by the prospective occupants who, for among other reasons, did not want to be associated with the poor, though they were poor themselves. Hassan Fathy's attempts at low-cost architecture were recognized as highly innovative abroad, but never achieved their intended goals, i.e. to provide a low-cost housing solution in Egypt.

Laurie Baker is an unusual example of a British architect in India who succeeded in providing popular low-cost housing alternatives for Indian poor. Laurie Baker's pursuit of viable low-cost design alternatives to prevalent state and commercially sponsored residential architecture is indicative of the struggle an architect might face he if attempts to practice outside the conventional approach towards design and construction. Laurie Baker's achieved objectives also shows that this form of 'active' design initiative outside convention is imminently necessary to promote change in a stagnant housing industry.

Laurie Baker's design experience is based on a thorough knowledge of the Indian environment which began with Baker's arrival in India in 1944. In the subsequent 18 years Baker designed and constructed hospitals that were maintained by his Indian wife who was a doctor. In 1977, 15

years later, Baker began an architectural practice, in the more conventional sense, in the region of Kerala which had been the setting of his previous projects for the medical mission.

The trademark of Baker's architecture is its innovative use of vernacular building methods and materials.

"I have tried not to be fanatical or purist in approach but rather to take a common-sense attitude to building problems as they exist today. I have not hankered after "the good old days", though I have a tremendous respect for all the effort our ancestors have put into coping with local climatic and social problems.

My technique has been to try to provide good workable plans and comfortable livable-in buildings for my clients and above all, to find ways of reducing currently high building costs so that house building may come within the reach of more and more people who never thought it would be possible for them. To do this I have eliminated much that is normally done but which is not strictly necessary. To achieve this cost reduction, all sorts of uses of the building trade's simplest, oldest and reliable materials have been tried out - brick and stone, tile and timber with attempts wherever possible to cut down on the use of expensive modern materials that are in comparatively short supply, such as steel and cement and glass."

Pg.31. Robin Spence, "Laurie Baker - Architect for the Indian Poor", Architectural Association Quarterly, Vol.12, No.1, 1980

Baker combines his knowledge of vernacular building methods and materials with the observational skills of an architect to create a new system of design priorities to reduce construction cost.

" Few people are willing to study the many and varied component parts of a house and work out a system of priorities. Yet it makes sense to cut the coat to fit the cloth. There are plenty of nice things one would like to have in one's house but, if there is a limited amount of

money available for building, one must be prepared to pick out the essential from the long, expensive list of 'nice' things. Colour-washed plastered walls are one obvious example. You may like them, but very rarely are they necessary; and in a typical, middle-class house the cost of such plaster and paint is equivalent to the cost of another complete room. Invariably it is propped open and a curtain used for the occasional privacy that is required. A hole and a curtain would have saved several hundred rupees from the original cost of the building. It is possible, and most desirable, to go through the many component parts of a building one by one and decide whether you really need them."

Pg.33, Ibid.

Baker's design practices led to opposition from the Indian government. 'Public Work Department' (P.W.D.) projects were continuously shown to be too costly, over-designed and mismanaged in comparison to Baker's design and construction projects. The P.W.D. was finally forced to relent in the face of growing press coverage, commissions and popularity for Baker's architecture. Baker's skepticism of the numerous applications of mainstream architecture is based on a common sense design approach distilled from his extensive experience in low-cost housing design.

" We sometimes claim that modern architecture is functional. Perhaps a few modern pace-setters are both functional and, in their own way, beautiful. Unfortunately, 99% of what is known as 'modern architecture', especially here in India, is purely imitative. Witness the epidemic of upside-down 'arches' that followed the building of the presidential palace in Brasilia. Architectural gimmicks and fashions publicized in architectural journals are quickly adopted and copied all over the country in a matter of weeks. Often these have no relevance or function in areas with different conditions of climate, geology, vegetation and cultural and social living patterns from those of the place where the original prototype was perhaps functionally conceived. All this world of fashion and of senseless meaningless imitation is invariably expensive and wasteful of materials. Such waste is, in my view, wicked when there are still millions

of people with nothing resembling a home. Let our 'fashions' and our 'styles' spring from the honest simple use of our local materials that are plentifully available. We must urge our scientists and research workers to help us use simple natural, albeit old-fashioned materials more effectively and more cheaply, so that we can have a truly indigenous modern vernacular architecture."

Pg.35, Ibid.

Baker also had difficulty enlisting aid from the commercial sector.

" Baker on site; unable to find contractors willing or competent to execute his designs, Baker recruited and trained his own workforce, and personally directed the work." Pg.33, Ibid.

In the last analysis, Baker realized that the occupants' needs were paramount in fulfilling design objectives. Baker criticizes 'wastefulness' as a problem of architecture as a whole not simply a concern of low-cost housing. Baker also emphasizes the human need for adequate shelter takes precedence over all other architectural considerations.

" I now rate the success of a building in direct proportion to the builder's and designer's understanding of the people who will live in it rather than his own technical abilities, skill and knowledge. I am now convinced that no material must be wasted or used extravagantly. Our building material resources are vast but the needs of our still increasing population are also great. Low-cost techniques and materials should not be considered only for the 'poor'. Our aim should be to design only the simplest buildings for all, avoiding ostentation and show. I am sure now that Gandhi was right when he said that a building in India should be built with materials which have all been found within a radius of five miles from the building site. Our skill and knowledge need to be directed towards methods of making most use of the simplest, least-costly materials for the benefit of the millions who have so little. I plead guilty to the charge that my work and efforts still leave virtually untouched the housing needs

of millions around me. Perhaps at best these words can be regarded as an introduction to a set of ideas which try to bring the possibility of building nearer to the common man. But I am only now fully realizing that this common man in so many cases in India is a villager who is unemployed for much of each year and has somehow to live on less than one rupee a day."

Pg.37, Ibid.

Passive and Active Design: A Dual Process -

An architect must recognize the difference between the 'passive' and 'active' approaches involving low-cost housing design in developing countries and consciously choose the appropriate path for the service he has to offer. Regardless of the path the architect may pursue, progressive housing development in the Third World requires input in both approaches.

From a larger perspective, both the 'passive' and 'active' approaches to low-cost housing design are complementary. In most cases, foreign architects hoping to provide design solutions for housing shortages in developing countries can only spend brief intervals of time in the vicinity of the sites they wish to design for - if they can afford to spend the time at all. These infrequent brushes with the actual cases of housing problems of developing countries provide insufficient experience for pursuing an 'active' design process. Nevertheless, brief first-hand experiences and well-researched second-hand knowledge adequately serve to concentrate on 'passive'

design solutions. 'Passive' designers provide the bulk of research and development in the field of housing development for Third World countries. Architects, engineers and planners carrying on research in their respective facilities perform a valuable service to global low-cost housing design by testing new directions in architecture and providing a steady flow of applicable construction innovations. The laboratories of the developed nations are better equipped and financially more capable of carrying on experimentation in potentially risky new construction technologies.

Active designers such as Laurie Baker, willing to immerse themselves in the lives of those they are designing for, are relatively rare in the field of low-cost housing development. Total immersion in a different society requires that the architect learn the language of those he intends to design for and live with them long enough to understand their needs. The period of time necessary for an intimate knowledge of the building context can vary - from two years with an organization such as the Peace Corps to a lifetime, as in the case of Laurie Baker.

Extensive field experience for foreign architects in developing countries, though rare, is an extremely valuable source of information. Such trips provide the vital link for 'passive' designers to the site and for native architects of developing countries a bridge to the technology of the developed nations. Occasionally, as in the

case of Laurie Baker , transplanted architects from the developed countries provide the impetus for a large scale change of housing policy in a developing nation.

(Figure 3.6 : Chart depicting the duality of the 'active' and 'passive' forms of design development.)

BUILDING FROM BELOW

The major architects of today's Third World cities are poor families building their own homes. The diagram below shows the percentage of squatters and slum dwellers in four major cities.

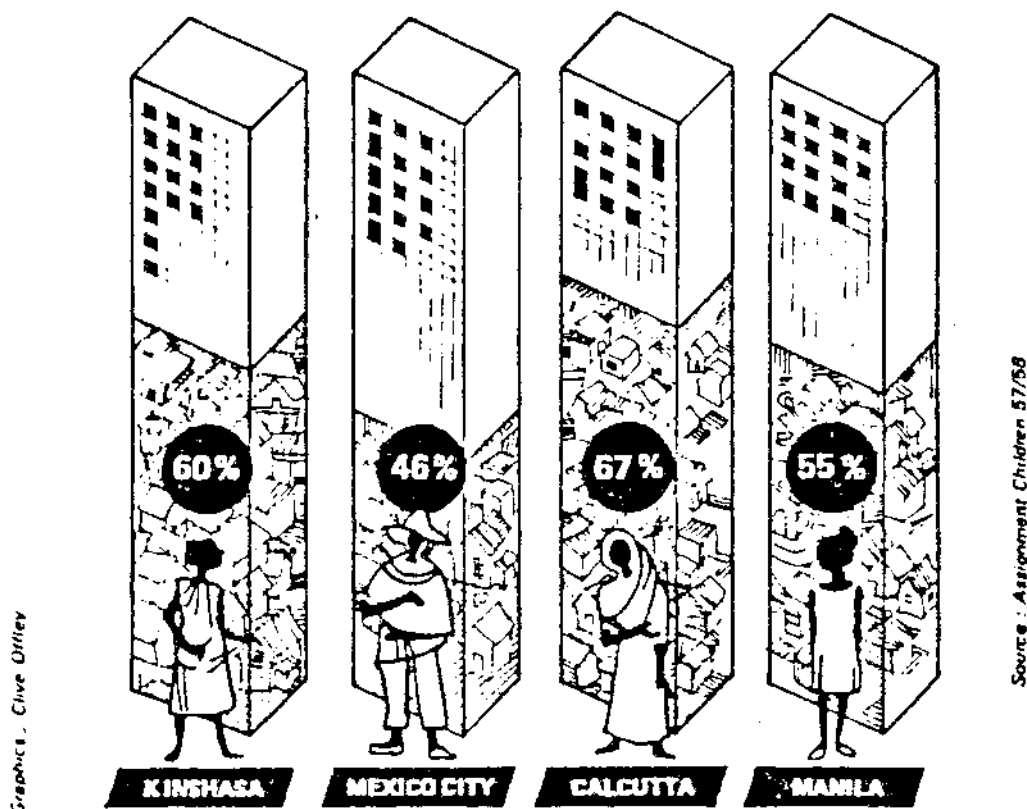

FIGURE 3.1

- Chart showing the percentage of those who build their own homes in four cities of developing countries.

Pg. iv, UNDP DOSSIER,
 United Nations Development Programme
 Division of Information
 One United Nations Plaza, New York, N.Y. 10017

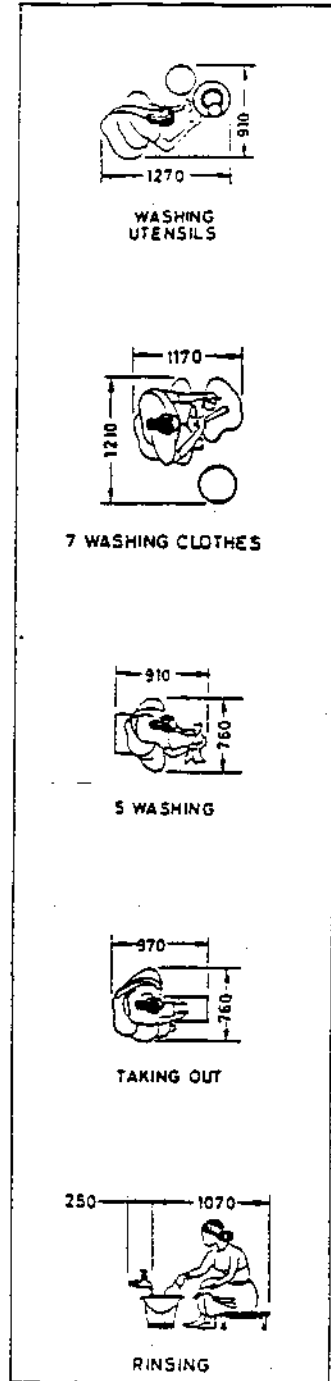
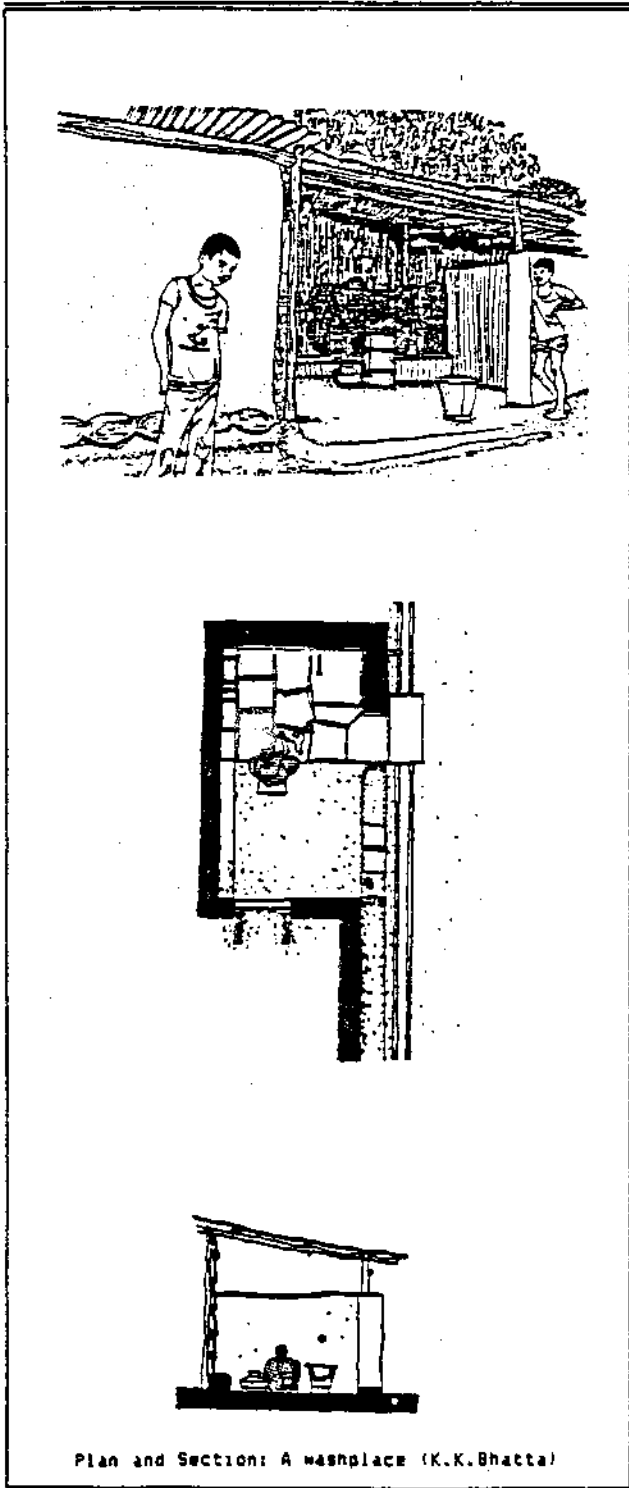
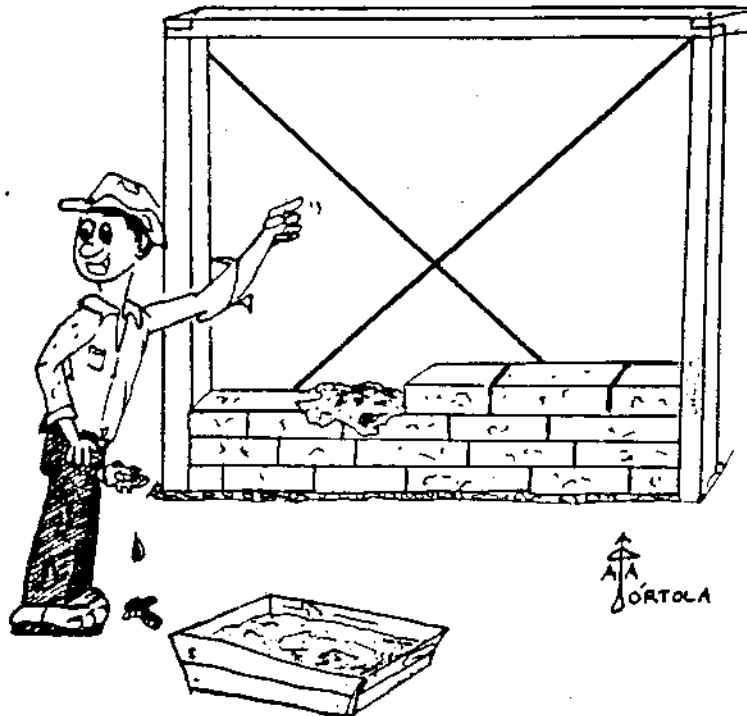

FIGURE 3.2: Washplace study.
FIGURE 3.3: Human Dimensions:Washing

Rybczynski, Witold
HOW THE OTHER HALF BUILDS, Vol.1: Space, Research Paper No.9
Montreal, Centre for Minimum Cost Housing, McGill U.,
Dec., '84

COMO HACER CASAS SEGURAS EN UNA ZONA PROPENSA A TERREMOTOS



PRINCIPIOS Y BASES ➡

FIGURE 3.4

Comic: "HOW TO BUILD A SECURE HOUSE IN AN EARTHQUAKE ZONE:

PRINCIPLES AND BASIS"

TREBAJO PREPARADO POR LOS ALBANILES DEL DEPARTAMENTO DE CHIMALTENANGO, CON ASISTENCIA TECHNICA DE INGENIEROS CONTRATADOS POR LA COOPERATIVA "KATO KI-QUETZAL," R.L.

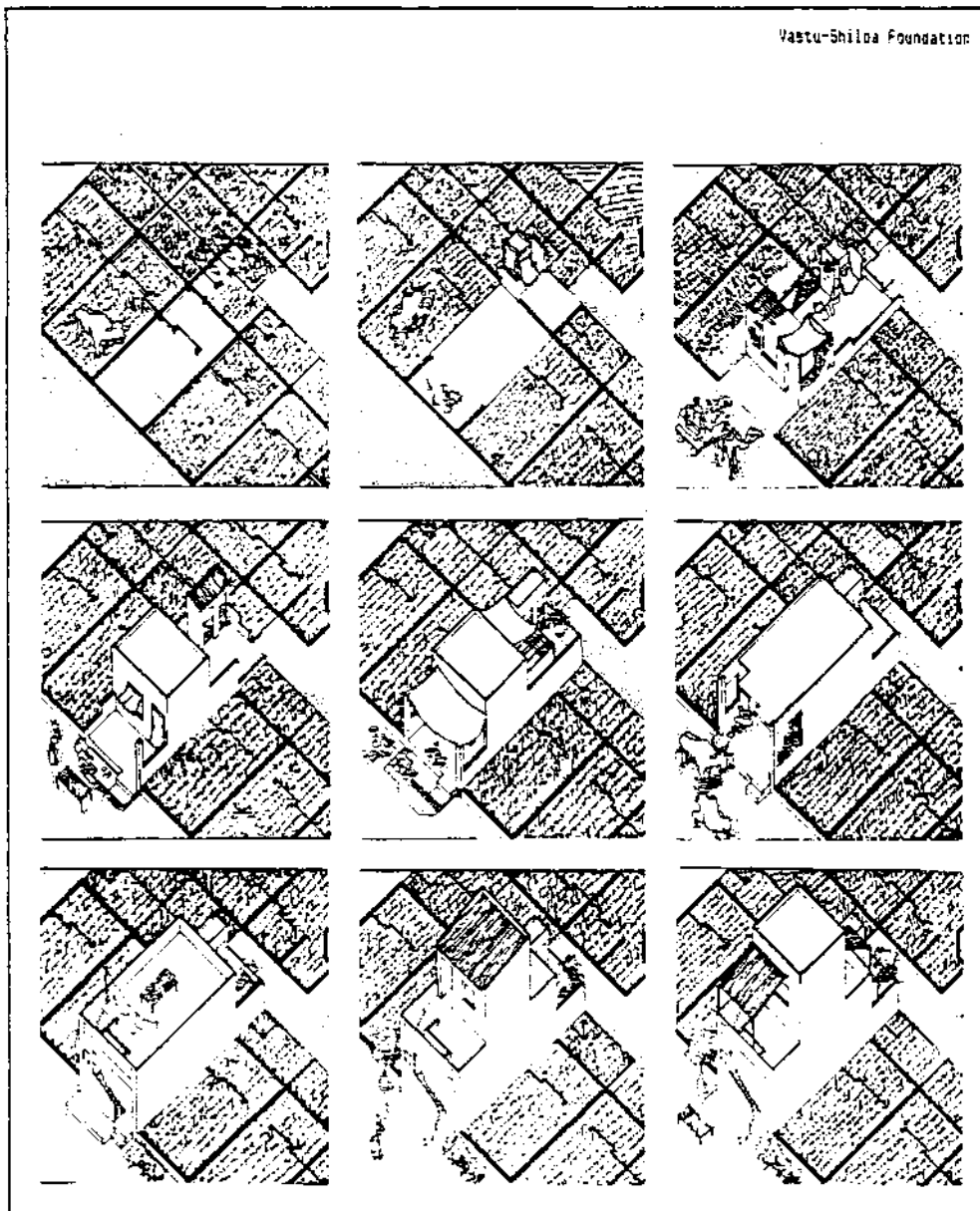

FIGURE 3.5

- Sites & Services: An Example of plot development.

Rybczynski, Witold
 HOW THE OTHER HALF BUILDS, Vol.2: Plots, Research Paper
 No.10, Montreal, Centre for Minimum Cost Housing, McGill U.,
 Dec., '84

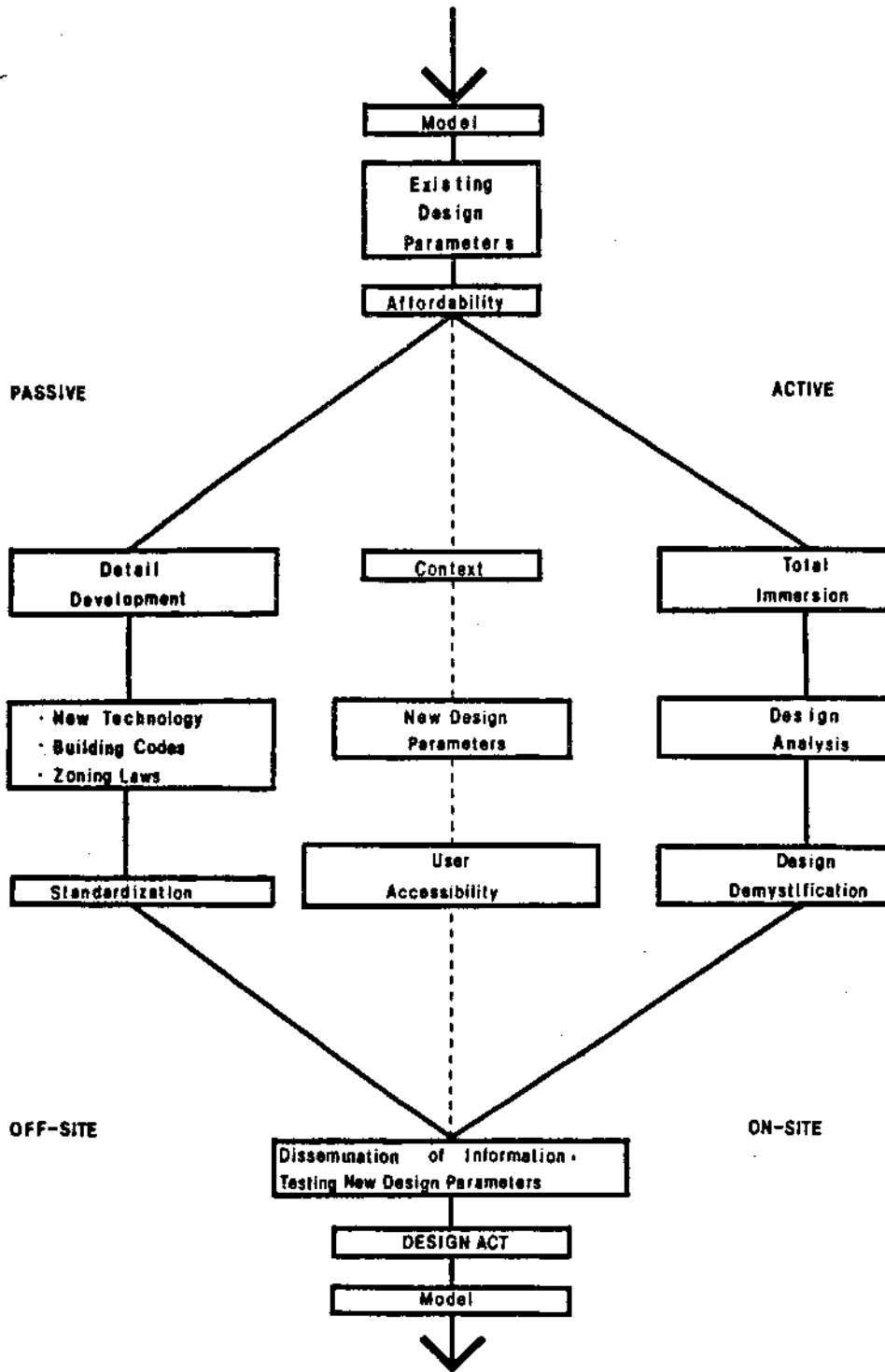

FIGURE 3.6

- Chart depicting the duality of the 'active' and 'passive' forms of design development.

CHAPTER 4
A CASE STUDY OF THE DOMINICAN REPUBLIC:
COUNTRY & HOUSING CHARACTERISTICS

Country

The Dominican Republic is a typical developing nation coping with an unmanageable housing deficit. For the purposes of clarifying the previous analysis, the following brief description of the country and some of its housing data can be used as a frame of reference.

Nation -

OFFICIAL NAME : Republica Dominicana

OFFICIAL LANGUAGE: Spanish

CAPITAL & LARGEST CITY: Santo Domingo (pop.1 1/2 million)

SECOND LARGEST CITY: Santiago

DIVISIONS: 3 regions and 27 provinces

POPULATION: 40,011,589 (census 1970)

(Figures 4.1 & 4.2: Maps)

Geographical Attributes -

LOCATION: The Dominican Republic is located on the second largest island of the Caribbean sea after Cuba, named Hispaniola. Hispaniola is 575 miles southeast of Miami, Florida, between the Atlantic ocean and the Caribbean sea. The Dominican Republic occupies the eastern two-thirds of Hispaniola and borders Haiti, which occupies the remaining third on the west side of the island.

AREA: 18,816 sq. miles (43,734 sq. kilometers),

GREATEST DISTANCE:(East-west) 225 miles;(north-south) 160 miles; (coastline) 1,017 miles

ELEVATION:(Highest) Pico Duarte, 10,249 ft. above sea level.

(lowest) Lago(lake) de Enriquillo, 150 ft. below sea level.

Climate -

The Dominican Republic lies in the tropical zone, but because of the high mountain ranges running east - west through the country, the climate varies. Generally, the Atlantic coast is tropical - particularly in the vicinity of the Samana peninsula. Between the 'Cordillera Septentrional'(the northern range) and the 'Cordillera Central'(the central range) lies rich agricultural land of a cooler climate. In the southwestern portion of the Dominican Republic, the land is extremely arid and portions of it are desert. Savannahs, used for large-scale sugar plantations are located in the eastern portion of the country. The temperature in the Dominican Republic is approximately between 80 and 85 degrees F. year-round. Rainy season lasts from May to November.

Economy-

CURRENCY: (Basic unit) Pesos. One hundred centavos equal one peso.

CHIEF PRODUCTS:(Agriculture) sugar cane, bananas, coconuts, cocoa, coffee, rice, tobacco (Minerals) rock salt, silver,

bauxite, copper (Manufacturing and processing) baskets, cement, cigarettes, rum, soap, sugar products, textiles.

- Tourism has steadily grown from the 1960s and early 1970s and has become a major source of income in addition to the aforementioned products.

- The stagnant economy has led to emigration for many Dominicans. The majority of emigrants move to Puerto Rico, many of them en route to New York city or Miami in the United States. Currently, there are more Dominicans in New York city than anywhere in the Dominican Republic except Santo Domingo. New York city has an estimated population of 350,000 Dominicans.

Government -

TYPE OF GOVERNMENT: Republic

HEAD OF STATE: President (4 year term)

CONGRESS: Senate, 27 members (4 year terms); Chamber of Deputies, 120 members (4 year terms) POLITICAL PARTYS: (Two

party system) Dominican Revolutionary Party (P.R.D.),

Reformist Party CURRENT PRESIDENT: Joaquin Balaguer

(Reformist Party)

The government of the Dominican Republic is unstable, and often has been subject to sudden and violent political reversals. The reversals since the 1960s have led to an assassination, a military coup, civil war and finally U.S. intervention with the subsequent occupation of O.A.S. peace

- keeping forces in 1965. After O.A.S. supervised elections in 1966, the following governments have been pressured by rightist military influences represented by president Balaguer. The right-of-center political interests are represented by the Reformist Party. The left-of-center political coalition is represented by the Dominican Revolutionary Party or the P.R.D. Because of the dubious political involvement of the United States in Dominican internal affairs, many Dominicans are distrustful of American influence. The unstable status of the government has been the partial cause for the stagnant economy and consequently the large-scale emigration to Puerto Rico and the United States. (Figure 4.3: Important historical dates.)

Architectural Influences

Environmental Influences -

The geographic and climatic features of a country form the initial influences on local housing typologies. Dwellings must, to a certain degree, reflect the prevalent climatic and geographic features of the site. Construction techniques must conform to the materials that are immediately accessible and the level of skill available within the vicinity of the site. Nevertheless the local environmental features are not the strongest generators of housing typologies in the Dominican Republic.

In spite of the climatic differences ranging from the arid conditions of the southwest to the tropics of the Samana penninsula, housing types vary little from region to region, except in the use of a few building materials.

The use of 'calicanto' - a mixture of pebbles and concrete is more evident in the arid areas as is the use of mud and wattle. This is due to the scarcity of wood in these areas. Coral blocks were used in the construction of colonial Spanish architecture on the coastal areas - particularly in the capital city of Santo Domingo. In the remaining areas of the Dominican Republic, wood and concrete block are the prevalent construction materials.

Social influences -

The political and historical information is important to gain a sense of the lack of continuity in the progression of Dominican society. The erratic and complex social progression of the Dominican Republic is reflected in the country's architecture.

The Dominican Republic exhibits many characteristics of a fragmented society typical of most developing nations. The perpetual internal struggles and the periodic intervention of regional powers such as the former Spanish and French colonial forces - and, more recently, the United States - have to a large degree prevented the emergence of a single strong national identity. This social factor

strongly effects the current housing trends in the Dominican Republic.

Dominican architecture is a product of these internal and external social influences. The predominant culture and the original influence on urban architecture is Spanish. Buildings exhibit Spanish features such as colorful stuccoed exteriors, arcades and intimate enclosed courtyards at the rear of the building. Wealthier establishments include terracotta roof tiles, ceramic wall and floor tiles as well as window alcoves with seats. Building materials range from burnt brick to coral blocks.

The proximity of Haiti and the steady migration of Haitians into the Dominican Republic has reinforced Dominican ties with its African heritage and is particularly evident in the western rural areas close to the Haitian border. Many houses are constructed of mud and wattle with thatched palm roofs. The exteriors are often white-washed and decorated in patterns. The houses are grouped so as to form communal back yards for cooking, and areas for tending children and domestic animals such as poultry and goats. One interesting feature in these communities is the use of cactus for fencing.

The Haitian connection also carries with it a stronger French colonial influence. The average rural Dominican house throughout the Dominican Republic is of clapboard construction with a pitched roof, often hipped. Louvered

French doors are commonplace and have developed into a unique Dominican architectural treatment. Larger rural establishments have raised, expansive front verandas and hipped roofs. With the exception of 'Dominican/French doors', these architectural features are visible in the southeastern United States where French colonial influence was once quite strong.

With the emergence of the United States as a strong regional power, the Dominicans have been increasingly influenced by the 'modern' American lifestyle. In addition to the strongly felt American presence in terms of economic and cultural integration, evidence exists of a change in housing types. A growing number of Dominicans are building houses that resemble stereotypical American-style single family dwellings, especially in the vicinity of urban areas. The American-style houses (often part of American-style housing developments) are uniformly set back from the street to provide a 'front' yard and a space for parking as opposed to the traditional Spanish house set closer to the street with an enclosed courtyard to the rear. The 'Dominican/French doors' have also been abandoned in current Dominican residential architecture in favor of a standard front doors and windows. These front doors have in some cases been embellished with small entry patios. New materials are used to build these modern dwellings, such as concrete and concrete block instead of wood. The use of

concrete and concrete block has also reduced the need for the still - prevalent pitched roof. A rapid growth of suburban sprawl is becoming evident around the larger cities of the Dominican Republic.

Housing Data

In gauging the housing deficit, the statistics must take into account those Dominicans that live in dwellings that are below adequate living standards. Considering the existing dwellings, the Dominicans live in conditions that in the subsequent charts are divided into three categories; inadequate, improvable and adequate housing conditions. The following data is as current as 1980 (Figures 4.4 & 4.5). From the charts concerning Dominican housing standards we can deduct that the urban poor make up a majority of those Dominicans living in housing conditions below the acceptable level.

In addition to the dwellings themselves, the Dominicans' access to water sources, plumbing facilities, sanitation, lighting sources and cooking fuel are indicators of the Dominicans' living conditions in connection with their housing standards.(Figure 4.6)

Observing statistics related to service access in the Dominican Republic reveals a discrepancy between the adequacy of the actual dwellings themselves and the services that help contribute to adequate housing standards. The

residents of the urban areas, in spite of their poorer housing conditions, receive more servicing of basic necessities than the residents of the rural areas. This phenomenon may partially explain why rural Dominicans are migrating to the cities in large numbers.

Referring to the previous statistics concerning the national, urban and rural housing standards, the present Dominican housing deficit stands at 400,000 single family units. To maintain the deficit at present levels, the Dominicans need to build 26,000 houses a year. The following chart indicates how much the Dominicans have managed to build between 1970 and 1980 (Figure 4.7). Note the distinction between the public and private housing in the "formal" sector and the separate column for housing in the "informal" sector.

INFORMAL SECTOR: Housing in the "informal" sector is defined as spontaneous construction without regard to official building codes and zoning laws. Housing in the "informal" sector is characterized by planlessness, backwardness in architecture and in the use of building materials, absence of a building industry, overcrowding, lack of sanitation and services, impermanence and, finally, a higher susceptibility to disaster.

FORMAL SECTOR: The "formal" sector includes housing built under specific building codes and zoning laws. The "public"

housing refers to construction sponsored by State funding. The "private" housing figures denote construction financed by private institutions as well as Dominicans who have built houses according to the building codes and zoning laws.

The figures for construction in the "informal" sector indicate a high proliferation of potentially inadequate housing that has been built in the Dominican Republic over the last 10 years. This possibility raises the need for effective housing development. The construction parameters are determined by the following constraints - beginning with materials. (Figure 4.8)

Though wood is commonly used, Dominican resources of wood are being drastically diminished. Dominican forests are now being protected, which has had the effect of limiting domestic lumbering. As a result, the Dominicans will increasingly have to import wood for construction. In spite of the growing difficulties in obtaining wood, it is a popular building material because it is easy to use, versatile and until recently, low cost. As the cost increases, the Dominican builders will have to learn how to preserve the wood they use. If used properly, it can last fifty years. However, because of the climate in the Dominican Republic, untreated, uncared for wood structures have a short life span.

Some of the durable low-cost materials not mentioned in the previous chart are:

1. Soil/cement blocks
2. Rammed earth
3. Adobe
4. Calacanto
5. Bamboo

1. SOIL/CEMENT BLOCKS - Soil/cement blocks can be easily manufactured on site at very little cost. The virtue of these blocks is that once hardened, they can be used in almost every way a regular concrete block would be used. They are manufactured with a portable mechanical press known as the "CINVA ram". The drawback of this particular material is that the soil/cement mixtures must be correct, otherwise there is a tendency for the blocks to erode. Soil/cement mixtures vary according to the site. Mixtures must vary according to the earth, sand or clay content of the soil. Some experimenting is required before the correct mixture can be achieved.

2. RAMMED EARTH - Rammed earth has many of the same qualities as soil/cement blocks except that it is packed in large sections for which sturdy forms are needed. Rammed earth is extremely durable and if constructed correctly, will provide excellent insulation with walls that "breathe". It is low-cost and long-lasting. One of the prominent flaws with the construction method in an urban context is that earth ramming is labor intensive. Also if built in a humid

climate, it takes a long time to dry.

3.ADOBE - Adobe is a clay made into bricks and dried in the sun. Adobe bricks can be manufactured on site and the initial clay costs nothing to use. The assets of adobe have been proven by its frequent use in Latin America - often in arid regions such as northern Mexico. Variations of this method include baking bricks in an on-site kiln. Adobe has been proven potentially dangerous in earthquake zones. Adobe is a heavy material and prone to collapse in the event of an earthquake.

4.CALACANTO - "Calacanto" refers specifically to the pebbles that are bonded together with a cement mixture. The mixture includes calacanto (pebbles), cement, sand and lime. Calacanto construction is quite durable and does not require reinforcing bars - the pebbles assure the necessary rigidity. Calacanto construction requires the initial cost of an adequate amount of cement. Otherwise its drawbacks are few.

5.BAMBOO - Bamboo is a versatile, light, strong, and easy-to-use material that has been used for many purposes in areas that are indigenous to its growth. The Dominican Republic is not a native soil for bamboo. However, bamboo grows quickly, is harvestable and will grow again as rapidly as before. A project involving the use of bamboo,

nevertheless, would require long-term, large -scale plans for bamboo cultivation in the Dominican Republic.

DESIGN CONSIDERATIONS FOR THE DOMINICAN REPUBLIC'S CLIMATIC CONDITIONS:

- The structure must provide shade for escape from the sun. eg. trellis, significant overhangs and other shading devices.
- The orientation of the house is important. eg. blocking the western sun.
- Roofs should be light colored or reflective and have good insulation qualities.
- In locating the intended structures, the architect should be aware of the air movement through the site. The "Venturi" affect can increase air velocity and provide natural air conditioning.
- Water proximity affects the humidity of the air, its coolness and in the case of poorer housing developments, provides basic necessities.
- The proximity of trees and vegetation help prevent water evaporation in dry areas and consequently preserves the ecosystem.
- The architect should provide the houses themselves with proper ventilation.

SOCIAL CONCERNS WHEN DESIGNING FOR THE DOMINICANS:**Rural context:**

- It is important that the kitchen and the bathrooms remain separated from the living quarters in the main house. Because of the hot climate, both the bathroom and the kitchen have to be well ventilated.
- Clusters of rural Dominican houses often share common back yards where the younger children can be easily tended and people can gather to eat communal meals. If there is a limited water supply, these areas are the best locations for communal water taps.
- People are outside more often. Therefore, living rooms as we know them in the United States, are smaller and social gatherings tend to take place on porches, covered patios and other such shaded areas that are not enclosed.
- The main living premise should be secure. The main reason for a complete enclosure in a tropical climate is for privacy and the security of possessions - unlike the western attitude of enclosing structures primarily for protection against the elements.

Urban context:

- Houses present a wall to the street with a barrier-like front facade. The front facade is often quite securely protected and acts to discourage intruders from the street. Nevertheless a common architectural element in the more

suburban and town-like setting is a front porch or patio where the residents can gather to watch the street. In the more urban setting, "Dutch" windows and window seats within the house take the place of front patios and porches. At night these windows can be secured from the street with shutters.

- Back yards are often partially or fully confined "Mediterranean" style courtyards where many of the meals and social functions occur. Within these courtyards are small gardens and often the household water source. In spite of the enclosed perimeters these back yard spaces are sometimes the location for small commercial enterprises.

- In the Dominican Republic, the identity of the house's occupant becomes very important - especially in the urban context. Front facades, doors and windows facing the street are often painted bright colors which serve to distinguish one house from another. In this sense, considering individual attitudes must be an intrinsic part of architectural decisions. The architect must steer away from 'mass' oriented architecture of the developed countries.

(Figures 4.9 - 4.15: Housing typologies in urban and rural Dominican Republic)

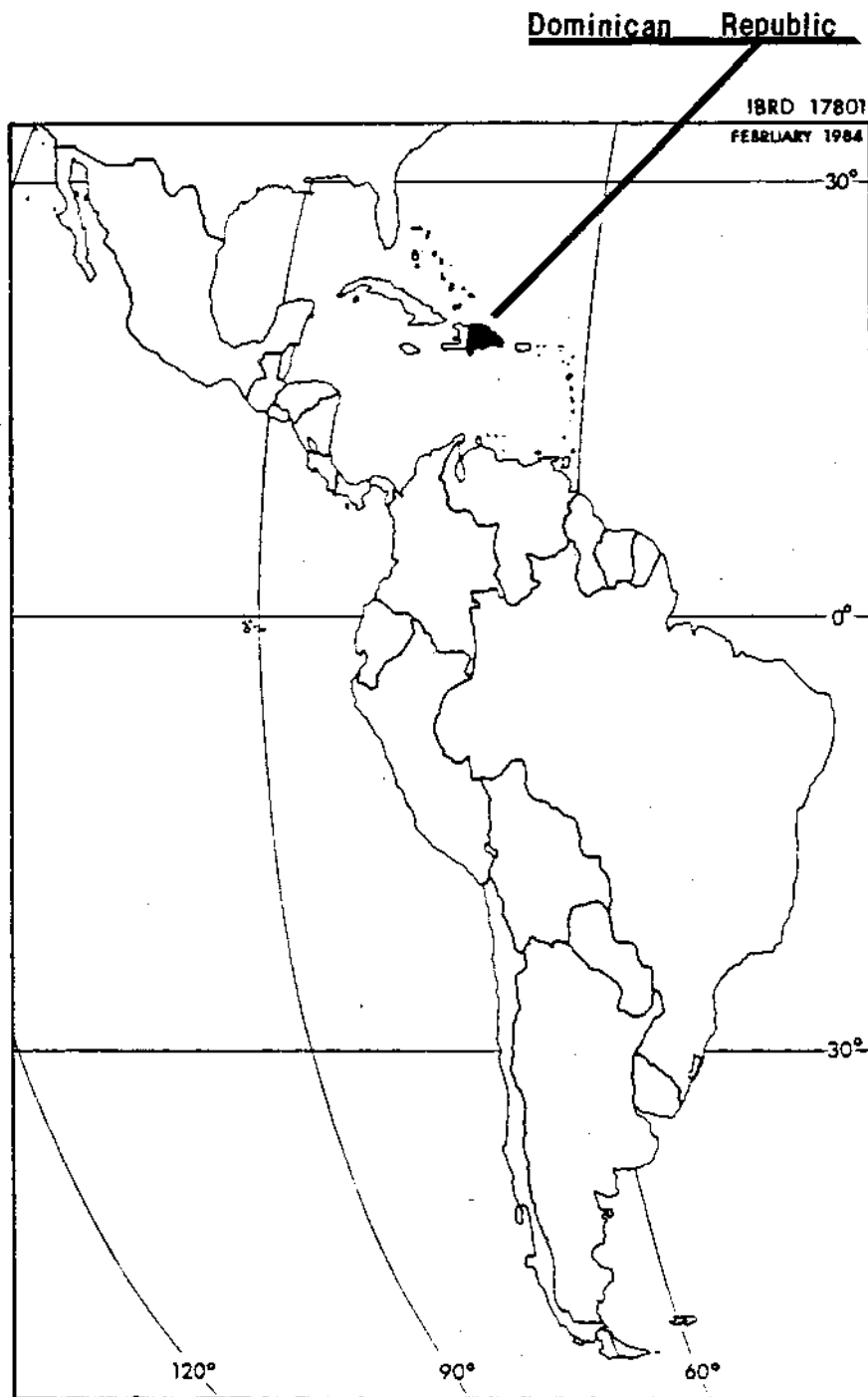

The Development Data Book, Teaching Guide
© The World Bank, Washington, D.C., U.S.A.
1984

FIGURE 4.1 - Map, source: above

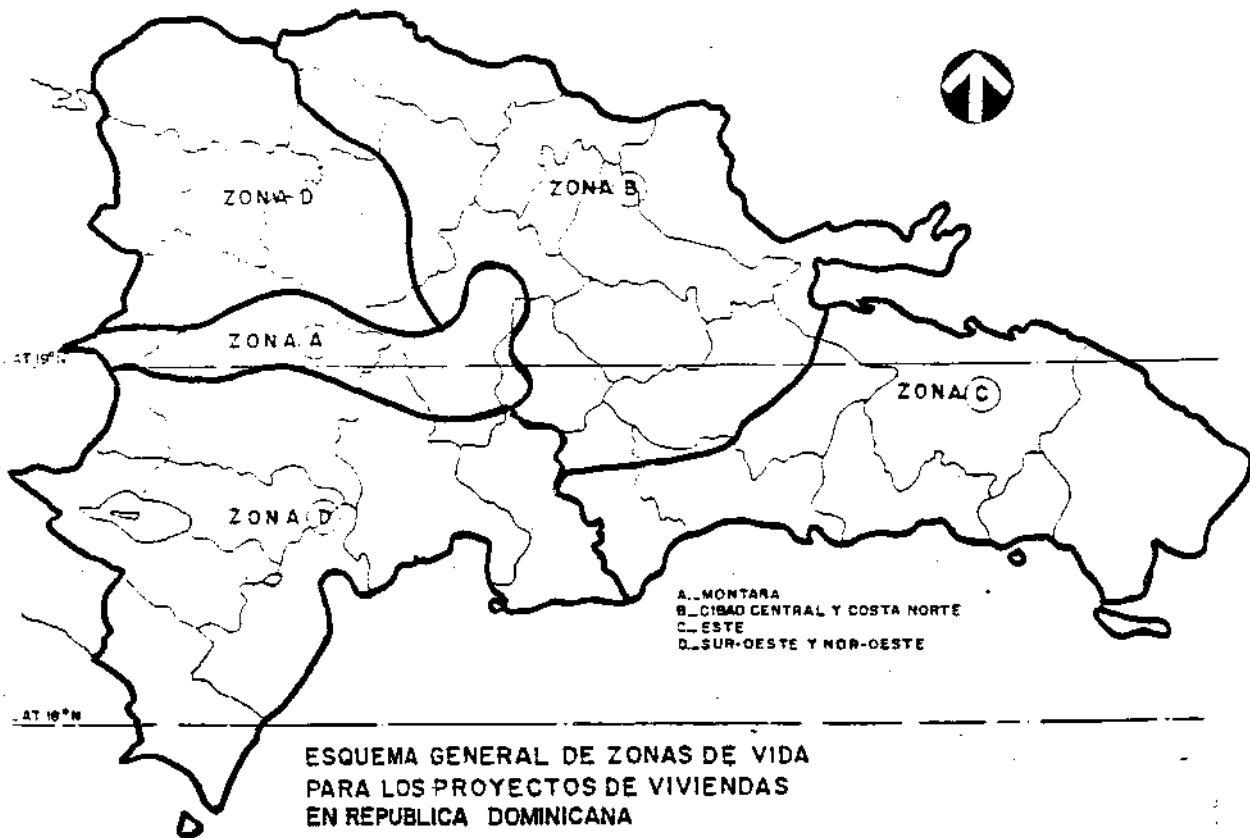
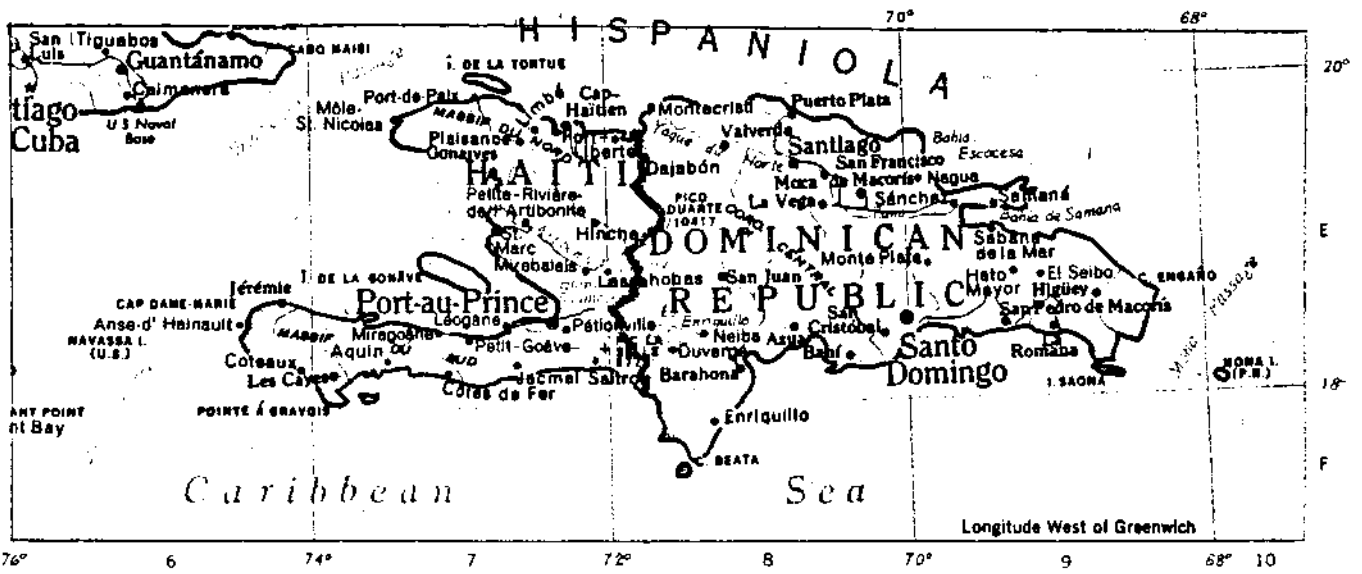

FIGURE 4.2- Maps, sources: Rand McNally World Atlas & FDP, INVI, CEA, "Estudio LaCienaga", VIVIENDAS DE BAJO COSTO EN EL SECTOR INFORMAL - SEMINARIO INTERNACIONAL, 30 - 31 January - 1 February, 1985, Santo Domingo, Rep. Dom.

History

- 1492 - Columbus discovered Hispaniola for Spain
- 1496 - 1st permanent European settlement in Western Hemisphere, Nueva Isabella, was founded.
- 1795 - France recieved the colony from Spain by the treaty of Basil.
- 1808-1809-Dominicans revolt against France and returned to Spanish rule.
- 1821 - Dominicans declare independence from Spain.
- 1822 - Invasion by Haiti.
- 1844 - Dominicans liberated from Haiti.
- 1861 - Dominicans request Spanish rule.
- 1865 - Revolt and liberation from Spain.
- 1916 - 1924 - United States occupation
- 1930 - Dictator Rafael Trujillo Molina comes to power.
- 1937 - Massacre of Haitians in the Dominican Republic.
- 1959 - Unsuccessful attempt to overthrow Trujillo.
- 1961 - Trujillo assassinated.

Recent History

- 1962 - Joaquin Balaguer deposed. Trujillo's right-wing (Jan.) influence temporarily ends.
- 1962 - New constitution. (Sept.)
- 1962 - First election since 1924. Juan Bosch elected. (Dec.)
- 1963 - Militarist coup deposes Bosch. Civilian triumvirate installed under Donald Reid Cabral.
- 1964 - Military supporters of Bosch rise against the government. Civil war in Santo Domingo. U.S. president Johnson sends in 20,000 troops. O.A.S. cease-fire.
- 1965 - Hector, Garcia Godoy who served under both Bosch and Trujillo, chosen as provisional president.
- 1966 - O.A.S. supervised elections, Bosch vs. Balaguer. Balaguer wins. Balaguer is pro-military, pro-church and right-wing.
- 1970 - Balaguer re-elected as president.
- 1974 - " " " "
- 1978 - Antonio Gusman (Dominican Revolutionary Party) elected as president.
- 1982 - Salvadore, Jorge Blanco (P.R.D.) elected as president.
- 1986 - Joaquin Balaguer (Reformist Party) elected as president

FIGURE 4.3 - Important dates in Dominican history

Pg.781, "Dominican Republic"

THE NEW COLUMBIA ENCYCLOPEDIA

Ed. William H. Harris & Judith Levey, N.Y.C.

Columbia University Press, 1975

| | | |
|--|--------------------------|---|
| ADEQUATE HOUSE- 23% | IMPROVABLE HOUSE- 44% | INADEQUATE HOUSE-33% |
| ROOF-corrugated zinc, asbestos/cement | -corrugated zinc wood | -scrap tin, cardboard palm thatch |
| WALLS-concrete block concrete | -wood,block/wood | -scrap wood,cardboard tin, palm thatch |
| FLOOR-concrete | -wooden floor | -packed earth |
| RM.S/HOUSE-4 or more | -4 or less | -2 |
| OCCUPANTS / 1 | | |
| BEDROOM -2 or less | -2 | -2 or more |
| SANITATION-private toilet | -outhouse | -outhouse or communal latrine |

FIGURE 4.4

- Chart representing typical examples of "adequate, improvable and inadequate" housing.

Gomez, Carmen with Antonio Tatis, Nelson Ramirez, POBLACION Y VIVIENDA EN LA REPUBLICA DOMINICANA. DIAGNOSTICA DEL SECTOR VIVIENDA Y PROYECCION DE OFERTA VS. NECESIDADES EN ESTA AREA 1985 - 2000, Santo Domingo, Republica Dominicana, Instituto Estudios de Poblacion Y Desarrollo IEPD, 1984

| | NATIONAL FIGURES. | | URBAN FIGURES | | RURAL FIGURES | |
|------------|-------------------|---------|---------------|---------|---------------|---------|
| | # units | % total | # units | % total | # units | % total |
| ADEQUATE | -272,019 | 24.4% | - 62,053 | 10.6% | -277,950 | 52.5% |
| IMPROVABLE | -478,263 | 43.9% | -255,822 | 43.7% | -222,889 | 42.1% |
| INADEQUATE | -364,550 | 32.7% | -267,530 | 45.7% | - 28,589 | 5.4% |

FIGURE 4.5

- Chart representing the number of units that are "adequate, improvable or inadequate" and the percentage of total housing in the Dominican Republic including statistics for the rural and urban zones. Ibid.

Percentage of Dominicans with access to running water:

| | NATIONAL | URBAN | RURAL |
|-----------------------|----------|-------|-------|
| RUNNING WATER INSIDE | 24.8% | 42.7% | 5.0% |
| RUNNING WATER OUTSIDE | 20.7% | 26.9% | 13.9% |
| NO RUNNING WATER | 54.3% | 30.4% | 80.8% |

Percentages of water sources used:

| | NATIONAL | URBAN | RURAL |
|-----------------|----------|-------|-------|
| AQUADUCT | 48.8% | 69.3% | 26.2% |
| RIVER | 22.7% | 0.8% | 46.8% |
| WATER TRANSPORT | 16.9% | 28.3% | 4.4% |
| WELL | 8.1% | 1.3% | 15.6% |
| NONE | 2.7% | 0.2% | 5.4% |
| OTHER | 0.7% | 0.1% | 1.4% |

Percentages of types of sanitation:

| | NATIONAL | URBAN | RURAL |
|-----------------|----------|-------|-------|
| PRIVATE TOILETS | 21.1% | 38.9% | 1.4% |
| PUBLIC TOILETS | 3.7% | 6.6% | 0.4% |
| PRIVATE LATRINE | 44.0% | 36.1% | 52.8% |
| PUBLIC LATRINE | 14.4% | 14.6% | 14.2% |
| BNONE | 16.7% | 3.8% | 30.9% |

Percentages of types of lighting:

| | NATIONAL | URBAN | RURAL |
|--------------|----------|-------|-------|
| ELECTRICITY | 59.1% | 91.2% | 23.7% |
| KEROSENE GAS | 39.9% | 7.9% | 75.3% |
| OTHER | 0.8% | 0.1% | 1.4% |

Percentages of types of fuels used for cooking:

| | NATIONAL | URBAN | RURAL |
|--------------|----------|-------|-------|
| ELECTRICITY | 0.4% | 0.5% | 0.3% |
| KEROSENE GAS | 3.8% | 6.8% | 0.4% |
| NATURAL GAS | 25.2% | 44.2% | 4.3% |
| CARBON | 34.0% | 41.4% | 26.5% |
| WOOD | 35.9% | 4.8% | 69.9% |
| OTHER | 1.6% | 2.2% | 1.0% |

FIGURE 4.6

- Charts representing services available to Dominican households. Ibid.

| | TOTAL HOUSING | | FORMAL SECTOR | | | | INFORMAL SECTOR | |
|----------|---------------|--------|---------------|------|----------|------|-----------------|-------|
| | # HOUSES | % | # HOUSES | % | # HOUSES | % | # HOUSES | % |
| NATIONAL | 443,185 | 100.0% | 44,697 | 9.9% | 20,677 | 4.7% | 377,829 | 85.3% |
| URBAN | 289,400 | 65.3% | 43,498 | 9.7% | 20,677 | 4.7% | 225,225 | 50.8% |
| RURAL | 153,785 | 34.7% | 1,181 | 0.2% | - | - | 152,604 | 34.4% |

FIGURE 4.7

- Chart showing houses built between 1970 and 1980. Ibid.

| | NATIONAL | URBAN | RURAL |
|----------------------------------|----------|-------|-------|
| WALLS:concrete, concrete block | 29.6% | 48.1% | 9.1% |
| wood | 36.2% | 45.4% | 26.1% |
| zinc sheets | 26.6% | 4.3% | 51.3% |
| tejamil yagua | 6.3% | 0.7% | 12.6% |
| scrap zinc, wood, cardboard etc. | 1.2% | 1.5% | 0.8% |
| ROOF:concrete | 13.5% | 23.8% | 2.2% |
| corrugated asbestos/cement or | | | |
| zinc sheets | 66.2% | 69.8% | 62.2% |
| palm thatch | 18.4% | 5.3% | 32.9% |
| scrap zinc, cardboard, wood etc. | 1.0% | 1.1% | 2.5% |
| FLOOR:tile, brick, rock | 13.6% | 24.8% | 1.1% |
| cement | 61.6% | 68.8% | 53.7% |
| wood | 3.2% | 1.2% | 5.4% |
| earth | 21.4% | 5.1% | 39.4% |

FIGURE 4.8

- Chart showing the prevalent building materials used in the Dominican Republic for housing construction. Ibid.

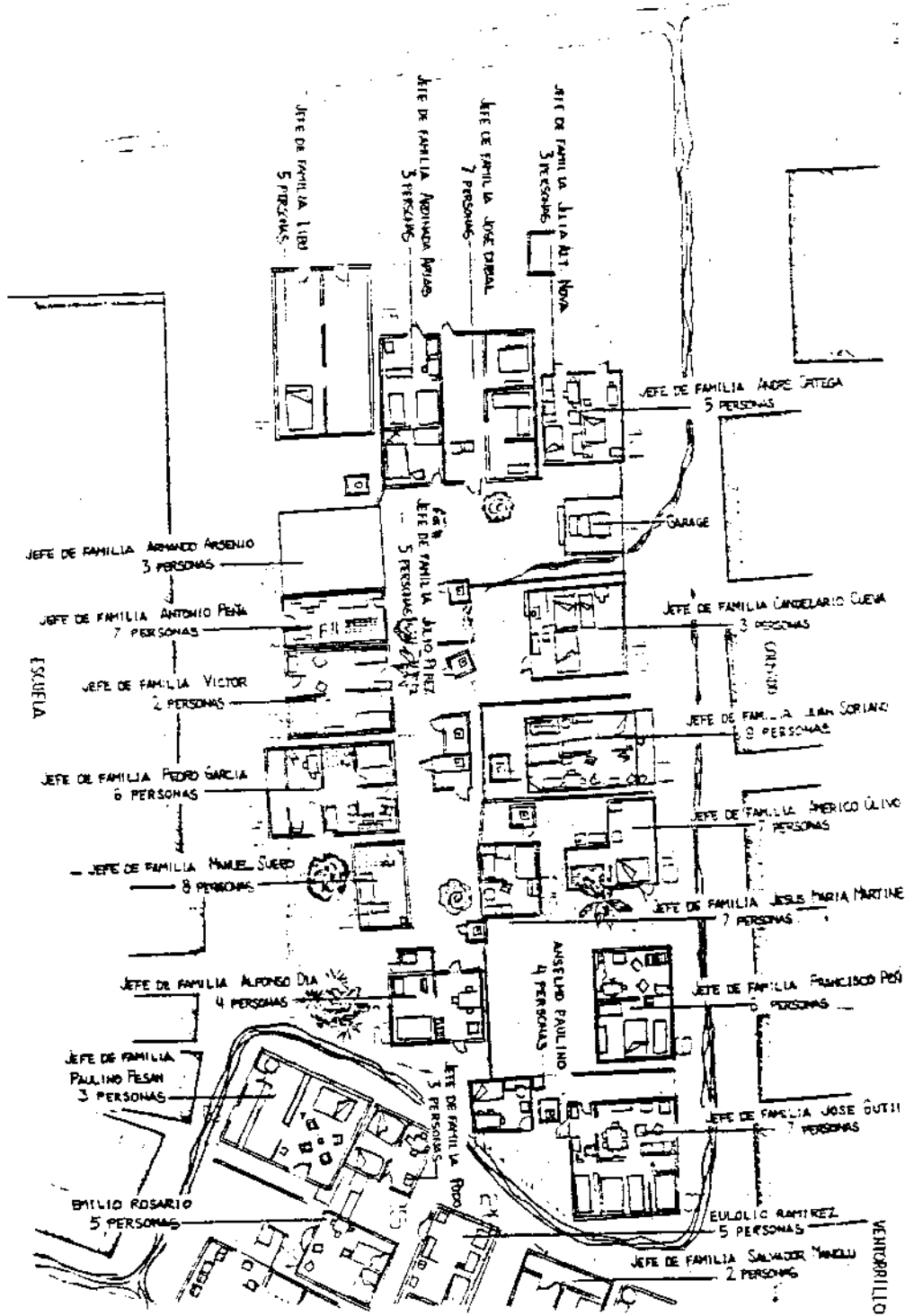
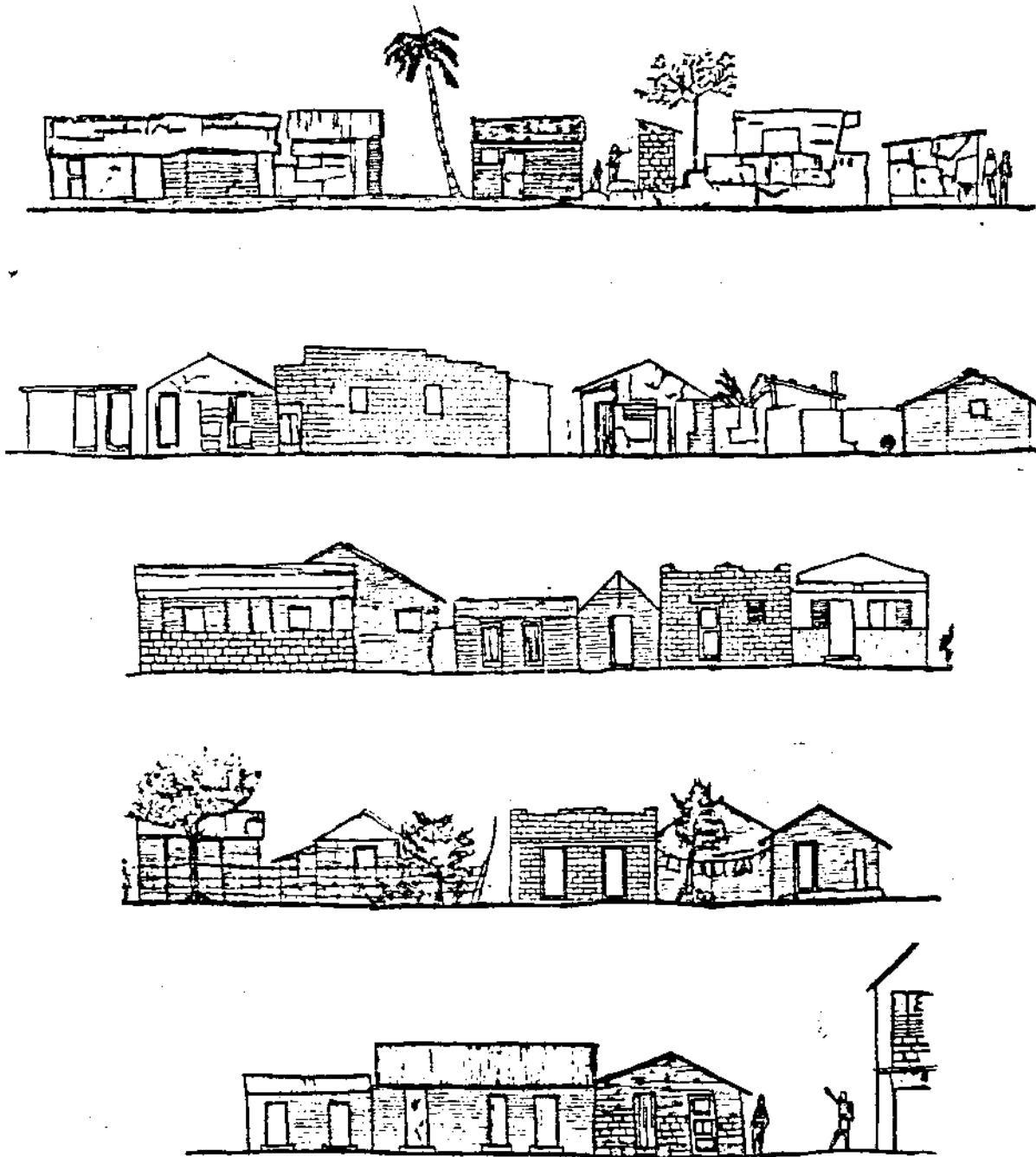

FIGURE 4.9 - Plan depicting a partial view of a community in the informal sector of La Cienaga in Santo Domingo, the Dominican Republic.

FDP, INVI, CEA, "Estudio La Cienaga", VIVIENDAS DE BAJO COSTO EN EL SECTOR INFORMAL - SEMINARIO INTERNACIONAL, 30 - 31 January - 1 February, 1985, Santo Domingo, Rep. Dom.



LA CIENAGA/SANTO DOMINGO ELEVACIONES DE UNA MANZANA

FIGURE 4.10 - A sample elevation of a community in the informal sector of La Cienaga in Santo Domingo, the Dominican Republic. Ibid.

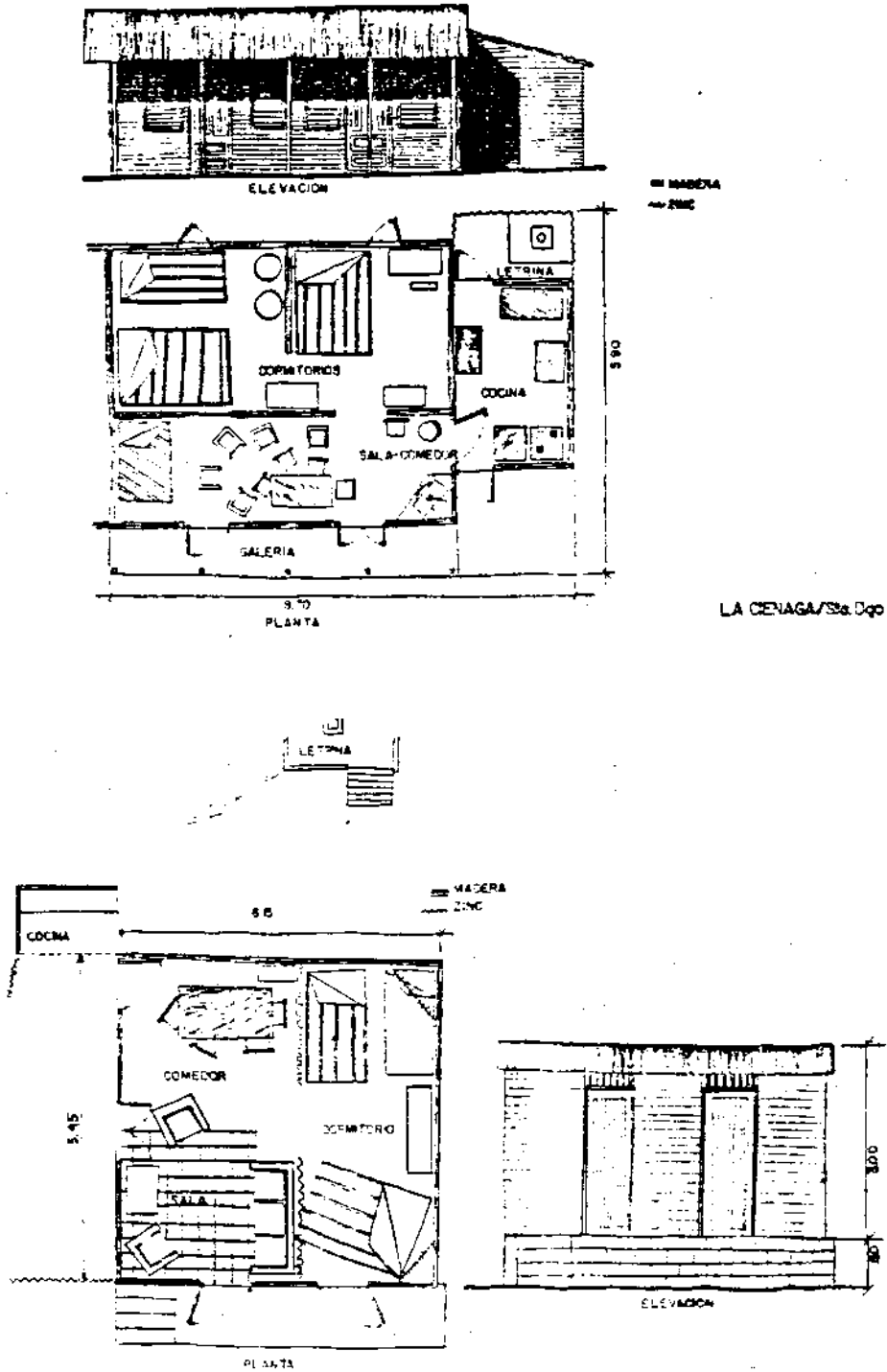
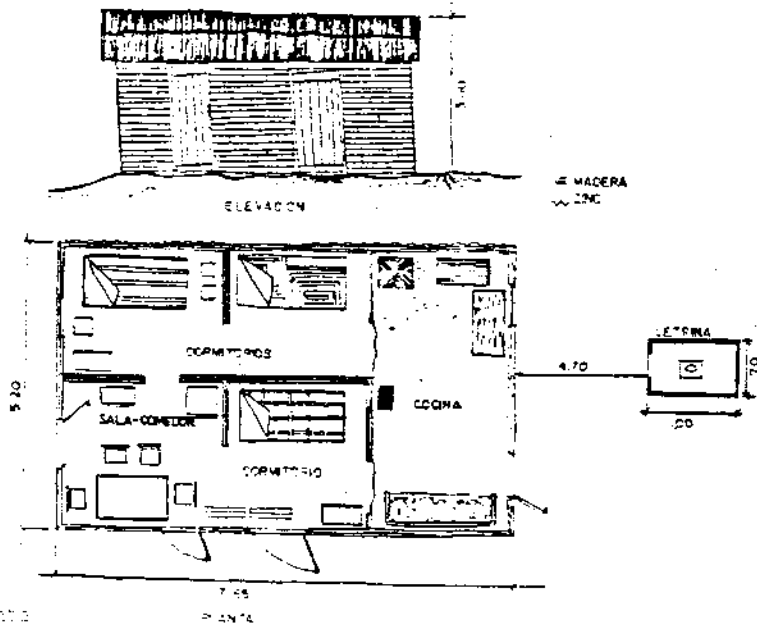
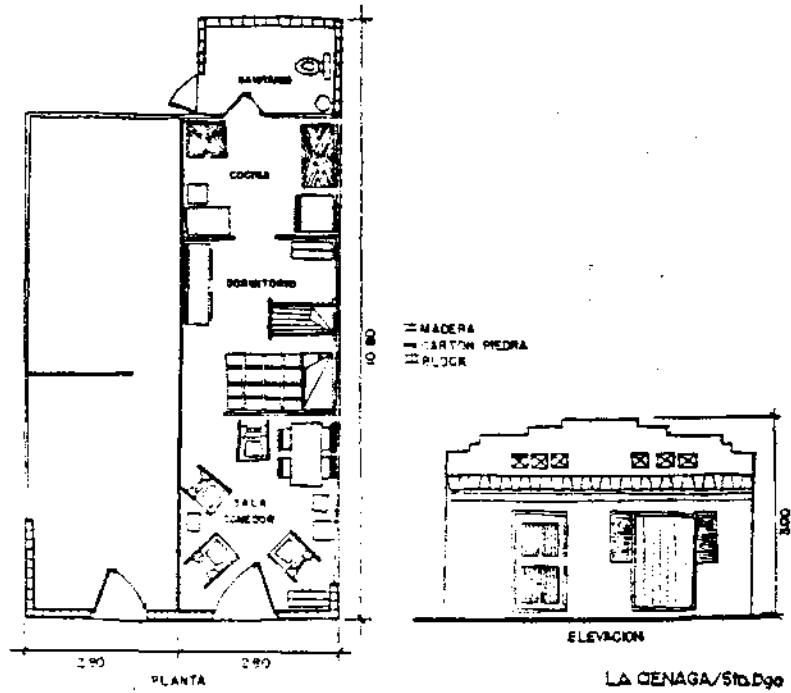
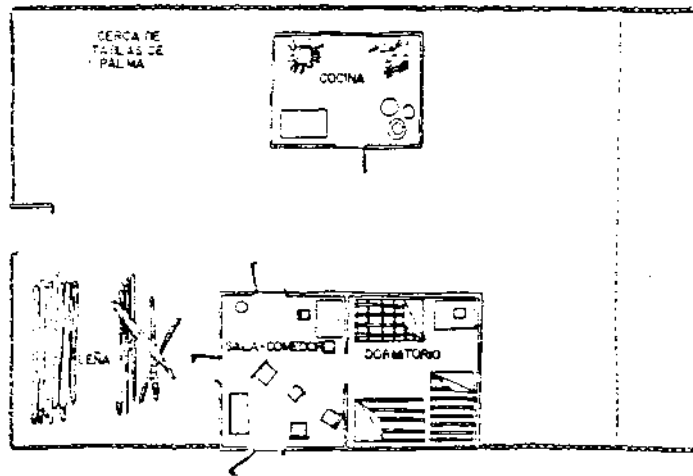

FIGURE 4.11 - Two examples of houses in the informal sector of La Cienaga in Santo Domingo, the Dominican Republic: plans and elevations. Ibid.



Estudio La Cienaga-FDP-DIVI-CEA

FIGURE 4.12 - Two examples of houses in the informal sector of La Cienaga in Santo Domingo, the Dominican Republic: plans and elevations. Ibid.



VIVIENDA RURAL/ Region Sur-Oeste

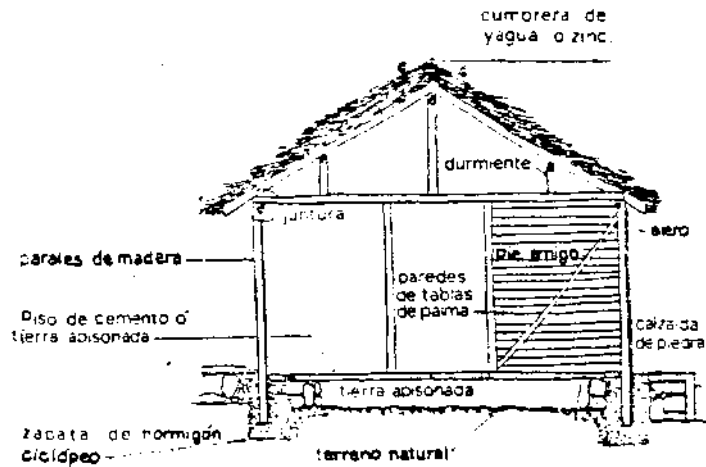

ESTRUCTURA DE VIVIENDA RURAL

Punto: Sur-Oeste

FIGURE 4.13 - An example of a house in the rural southwest of the Dominican Republic: plan and section. Ibid.

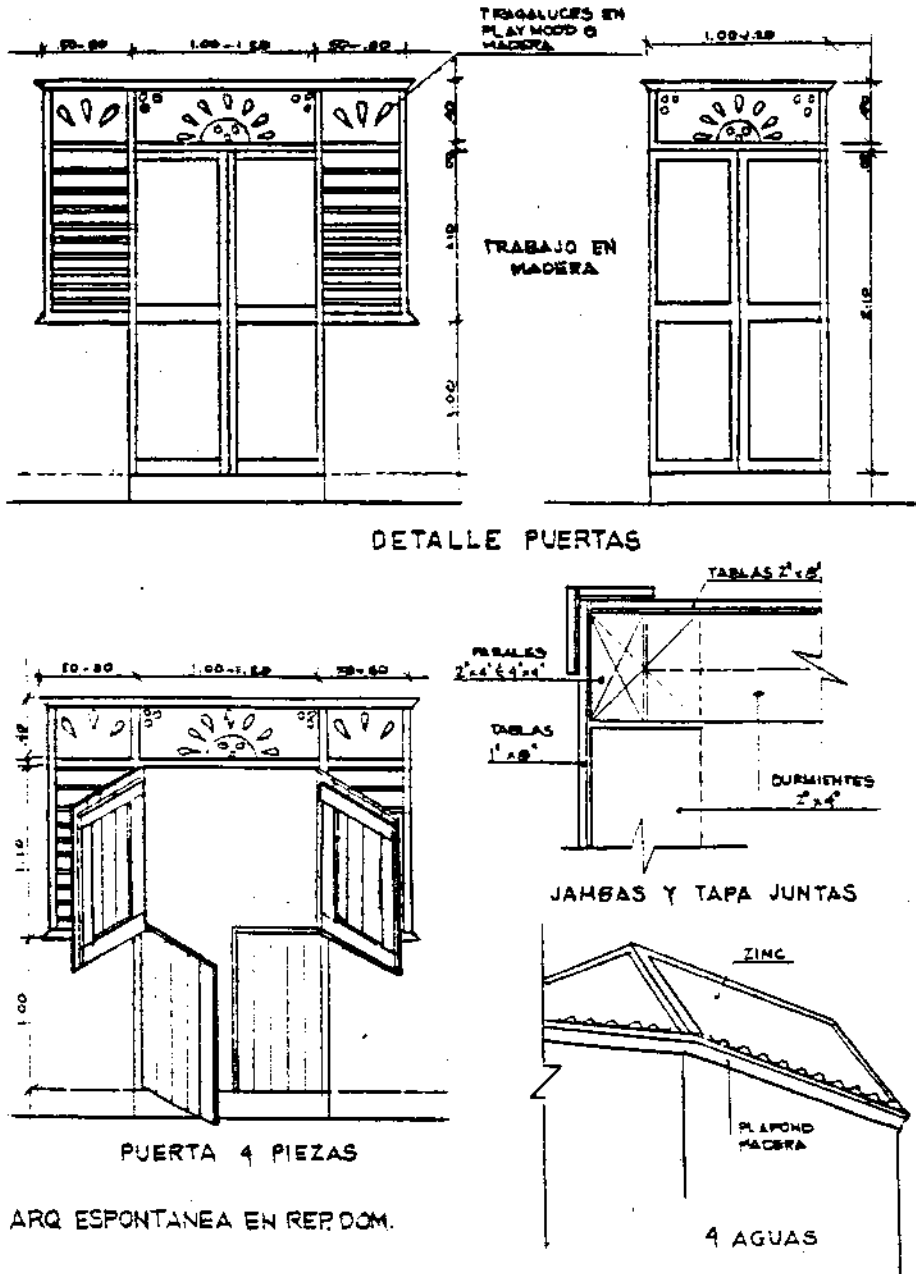

FIGURE 4.14 - Detail of a typical Dominican/Dutch door.

Ibid.

HOUSES FOR LA CIENAGA
 4/11/68

NOTE: MATERIALS - FOUNDATIONS OF TYPICAL CONCRETE SLAB (SEE MORPHOLOGICAL ASPECTS DOMINICAN HOUSES)
 WALLS EITHER ENTIRELY CONCRETE BLOCK OR WOOD OR BRICK WALLS C.M.U. ON FRONT REAR ELEVATIONS IN WOOD

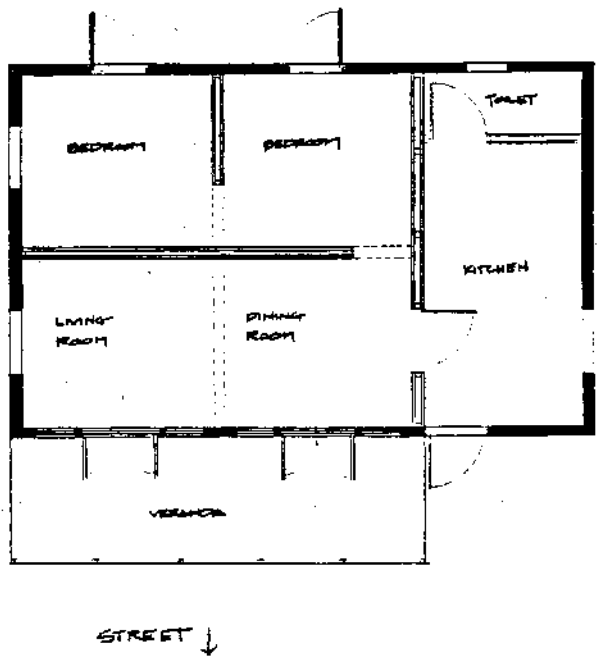
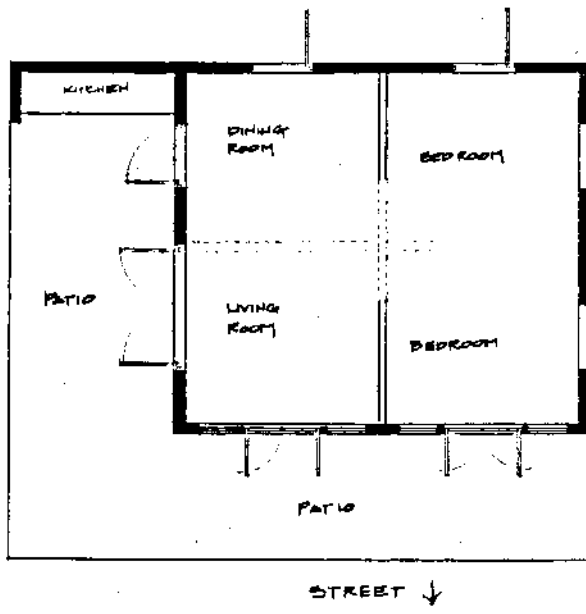
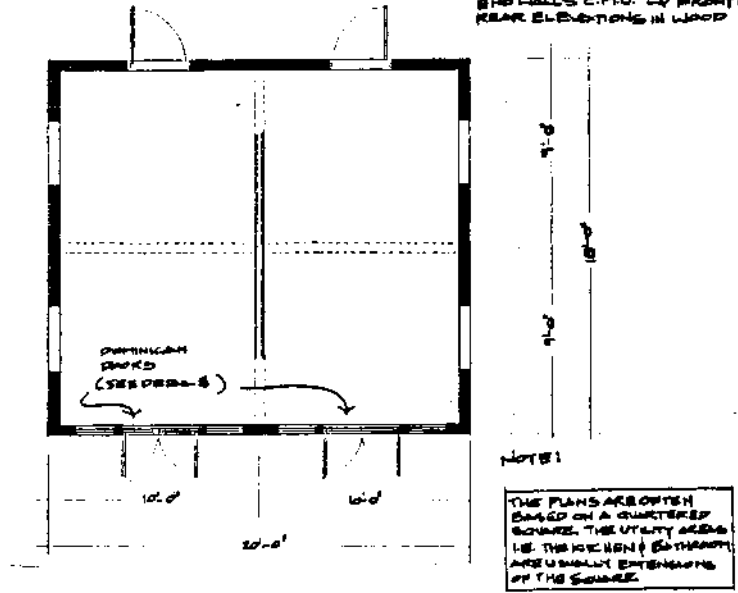

FIGURE 4.15 - Observations of housing patterns and their possible variations in La Cienaga, Santo Domingo.

CHAPTER 5
DOMINICAN LOW-COST HOUSING SEMINAR:
POSSIBLE LOW-COST HOUSING SOLUTIONS FOR THE
DOMINICAN REPUBLIC

The unstable politics and economy of the Dominican Republic illustrate some of the problems of generating housing development in the Dominican Republic. The lack of a stable economy discourages capital-intensive housing development as well as foreign investment in housing development, whereas uncontrolled inflation discourages projects requiring long-term financing. Meanwhile, the destabilizing political strife between the leftist Dominican Revolutionary Party (P.R.D.) and the rightist Reformist Party has discouraged long-term housing plans requiring political continuity.

The Dominican housing authorities have reacted to these problems by directing their attention to economic inducements and technical education campaigns intended to initiate a more 'visible' construction industry in the informal sector as opposed to the clandestine erection of squatting communities currently rampant in the informal sector. Dominican housing problems were directly confronted in the low-cost housing seminar sponsored by Dominican housing authorities.

The following data is based on information obtained at the international seminar on low-cost housing in the Santo Domingo in the Dominican Republic. The subsequent summary briefly describes the content and purpose of the seminar.

" International Seminar on Low Cost Housing -

CII-VIVIENDAS held an international seminar, "Low Cost Housing in the Informal Sector," from January 30 to February 1, 1985. Five agencies collaborated with CII-VIVIENDAS as sponsors for the seminar: Dominican Association of Engineers, Architects and Surveyors (CODIA), National Housing Institute (INVI), Rochester Institute of Technology (RIT), Agency for International Development and the German Society for Technical Cooperation (GTZ). Representatives of public and private sector institutions involved or interested in promoting housing for low income people in developing countries were invited to attend. Of the 155 participants who attended the seminar, 135 were invited by the sponsoring agencies, and 20 persons requested permission to attend. Approximately 78 percent came from the Dominican Republic and the remainder represented Germany, Switzerland, the United States, and eleven other Latin American countries.

The seminar had four major objectives: to promote awareness of low income housing in the informal sector; to capitalize on the experiences of other national and international institutions engaged in this type of work; to develop recommendations to improve programs; and to establish a plan for the coordination of institutions engaged in work on housing problems. Thus, the seminar was conceived as an opportunity for professionals to exchange ideas and develop cooperative strategies to enhance their work.

At the end of the conference a committee of seminar participants prepared a document which provided a synthesis of the conclusions and recommendations made by the various working groups. These recommendations included the need to develop low income housing policies and strategies designed to :

- Eliminate paternalistic assistance to low-income groups.
- Reinforce technical assistance to the informal sector.
- Encourage beneficiaries to participate in the design of their housing projects.
- Assist communities in developing micro-industries that would produce construction materials using appropriate technology.
- Implement a revolving fund which provides community organizations with low interest loans repayed from revenues attained from micro-industries that would profits. This fund

would be available to all member organizations of CII-VIVIENDAS and would be administered by CII-VIVIENDAS.

- Create a bank of library materials on low income housing policies and programs.

In order to evaluate the effectiveness of the seminar, CETAVIP conducted a survey of participants. The responses indicate that most participants felt that the seminar had accomplished at least some of its objectives."

Pg.16,DIFFUSION PROGRAM CENTER FOR APPROPRIATE TECHNOLOGY FOR POPULAR HOUSING - SECOND YEAR EVALUATION, Milagros Nanita-Kennett and Patricia Klobus Edwards, College of Architecture & Urban Studies, Virginia Polytechnic Institute & State University, Blacksburg, Virginia, 24061

The subsequent examples of affordable housing proposals presented at the seminar represent three perspectives in the broad spectrum of low-cost housing development strategies including:

- comprehensive development plans of the Argentinian contingent representing the Institute of Environmental Preparation, College of Architecture and Urbanization of the University of Tucuman,
- the specific design of a low-cost housing unit presented by Colombian architect Santiago Moreno ,
- the testing and production of corrugated fiber cement tiles by CII-VIVIENDAS in the Dominican Republic.

LOW-COST HOUSING DEVELOPMENT PROPOSAL:
TITLE: LOW-COST HOUSING IN THE INFORMAL SECTOR

Institute of Environmental Preparation
College of Architecture and Urbanization
University of Tucuman

To choose the "developmental option" of a particular area requires a detailed assessment of existing developmental experiments and their effect on the "targeted" area. At the Cii-Viviendas sponsored housing conference of January and February 1985, this topic was discussed extensively with an unofficial consensus at the close of the conference in favor of an Argentinian research contingent's proposal for combatting the housing problem in the "informal" sector.

This unofficial consensus reflected a compromise between the recognized "formal" elements of the conference which included Dominican housing agencies affiliated with the Dominican government and banking concerns, as well as "informal" elements obliquely represented by local Dominican student organizations.

The "formal" elements of the conference supported a structured developmental process that resulted in completed housing projects financed by "floating" loan schemes and special tax funds. The "informal" elements opted for a radically reorganized system of land tenure and localized building industries based on "appropriate technology".

With the exception of the Argentinian contingent, foreign participants of the conference avoided the

contentious issue of "development", choosing instead to present various low-cost or growth-related building systems. The Argentinian contingent represented the "Institute of Environmental Preparation" of the Architecture and Planning Department at the University of Tucuman in Argentina.

The presentation was titled, "Low Cost Housing in the Informal Sector" and described an outline of implementing a viable developmental policy, "...bent on contributing to the 'optimization' of the material and human resources available in each community."

pg.1, "Low-Cost Housing in the Informal Sector"
 Institute for Environmental Preparation
 College of Architecture and Urbanization
 University of Tucuman
 Seminar on Low-Cost Housing for the Informal Sector
 Jan.30 - Feb.1,1985, CII-VIVIENDAS, Santo Domingo, D.R.

Though the report is meant to account for all the developing nations of milder climates where the housing problems are prevalent, the focus is on "sociological and climatic microzones" with the intention of nurturing "basic microzonal housing". The objective was to promote housing construction at the grass-roots level with the maximum use of localized material and labor augmented by technical and financial aid from the "formal" sector to improve native construction methods and building systems. Each microzone would have a technical vocational center that would specialize in that region's environmental and social characteristics.

The initial step of such a program would be a thorough assessment of each targeted microzone provided by the inhabitants and compiled at regional headquarters, after which communities would be classified according to social, material and climatic similarities. The goal of such a program would be to conduct this research outside political and national constraints, thereby forming an informational base that could be used for similar microzones of different nations.

The institute concluded that the fostering of development depends largely on the incentive provided to those of the "informal" sector. Decentralization was suggested as conducive to initiating incentive in the "informal" sector. In a broader scope, there was to be a shift towards encouraging individual responses to the housing problem rather than viewing the problem as a national plan to be confronted in a massive, coercive manner. In this sense, the "formal" sector's role in development would change. The "formal" sector would take a passive role in development rather than an active role. The housing authority's services would change from sole "official" provider to "resource bank". In theory, delegating the responsibility of housing provision to those who lack it - with full authority to make their own housing decisions, in turn requiring a commitment from those who suffer the housing shortages to provide for themselves. In

this way, the housing professionals of the formal sector, ie. the architects, are spared the minute decisions of providing building or design options for a myriad of dissimilar lifestyles, whereas they retain the the authority to concentrate on problems of a more architectural or constructional nature. Consequently leverage from within the ranks of those living inadequately would induce many to seek the aid of a housing authority that can provide efficient low-cost solutions to their housing problems.

In short, the Argentinian contingent proposed a "laissez - faire" system reinforced by a network of localized aid institutions intended to prompt housing evolution as hubs of training programs, financial aid, technical aid , material aid etc.

The initiation of such a program of development would depend upon solving the problems commonly associated with "incentive" schemes. One such problem would be the act of providing land tenure to those in "squatting" communities which often make up a large part Third World urban slums - with the minimum amount of relocation. With the exception of those habitations located in environmentally unsafe areas, such as flood plains and earthquake zones, existing slum communities would have to be upgraded. Initially, the threat of forced evacuation would have to be removed. Evaluations of what constitutes "squatting" would have to be redefined. Criteria for "eligibility" to own property would

have to be formulated, stressing a constructive return, eg. In some American urban renewal programs, participants provide "sweat equity". Municipal ordinances for construction and planning would have to be adapted to influence construction rather than limit it. Financial, material and technical inducements would have to be organized to spur home-building. The objective of these social adjustments would be to induce a sense of permanence among residents of a poor community which eventually becomes the source of a solid housing foundation. In summary, the Argentinian contingent suggested the following political alternatives:

- " - Decentralizing the administration of resources.
- Support of the informal sector and the recognition of this sector as a valid source and system of production capable of decreasing the housing deficit.
- Realistic modification of the prevailing construction norms.
- Promotion of unconventional housing operations.
- Recognition and support of grass-roots housing organizations and institutions." pg.3, Ibid

In regard to the architects' role in this problem the Argentinians state;

"The distinct disciplines that concur in the area of housing, must be presented with the intention to transform the knowledge generally held by elite professionals into simple and appropriate tools for the (targeted, poorly sheltered) users, as much on an individual level as a group level which allows for user autonomy early in the development process and promotes development with the users as the "subjects" of their own course rather than the users as "objects" of a course planned for them." pg.7, Ibid

Some characteristics of this approach would be:

- " - Simplification of construction and equipment
- More attention to the microeconomic aspects of providing shelter.
- Prompt implementation.
- Providing new fields of employment.
- Potential fusion with other areas of constructional necessities eg. services, sanitation etc.
- Humanization of the production processes of housing components and construction." pg.7,Ibid

LOW-COST HOUSING DESIGN PROPOSAL:
A HOUSING DESIGN FOR THE SETTLEMENT OF THE ORINQUIA AND
AMAZON RIVERS IN COLOMBIA

Architect: Santiago Morena

The following design proposal is intended as part of a settlement project currently underway in the rain forests of southern Colombia. The architect, Santiago Morena, was especially concerned about preserving the fragile ecosystem of the rain forest without compromising the lifestyles of the settlers. The housing system was designed according to the subsequent parameters:

- The design must be flexible and simple so as not to constrain the living habits of the future occupants and necessitate strict construction supervision. The design also requires flexibility because of the site requirements of a rain forest.
- The design must be conducive to construction variations so that the constant use of the design formula does not result in the oppressive repetition of identical structures.
- The housing system must be conducive to the use of appropriate technology in the local environment.
- The housing system must be based on living conditions that distinguish less between the indoors and out.

The design model was sponsored by the Pioneer Institute of the Araracuara Corporation in conjunction with UNICEF for the rural area of San Jose de Guaviare as well as tropical climatic zones with similar construction conditions.

As indicated in figures 5.1 - 5.5, the integral unit of this housing design is the soil-cement or CINVA - ram block wall in the shape of a bracket. The bracket design is conducive to a number of different configurations as well as incremental construction (figure 5.7). The bracket design can also be used in conjunction with the 'roof-loan ' system of construction inducement.

(Figure 5.1 : The support system.)

(Figure 5.2 : The basic structure.)

(Figure 5.3 : The living unit.)

(Figure 5.4 : The bathroom unit.)

(Figure 5.5 : The kitchen unit.)

(Figure 5.6 : Stove)

(Figure 5.7 : Possible unit configurations.)

SISTEMA DE SOPORTE

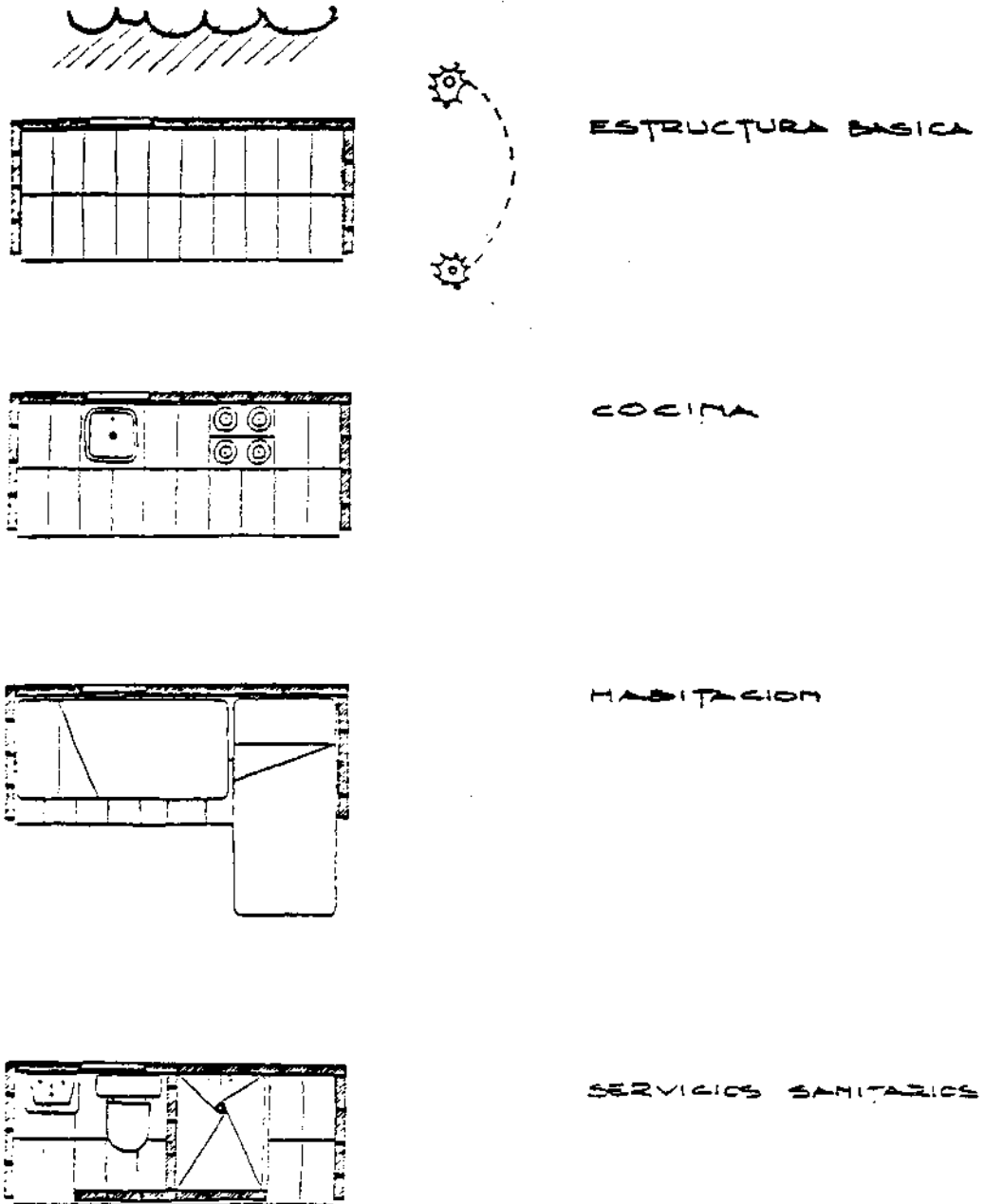
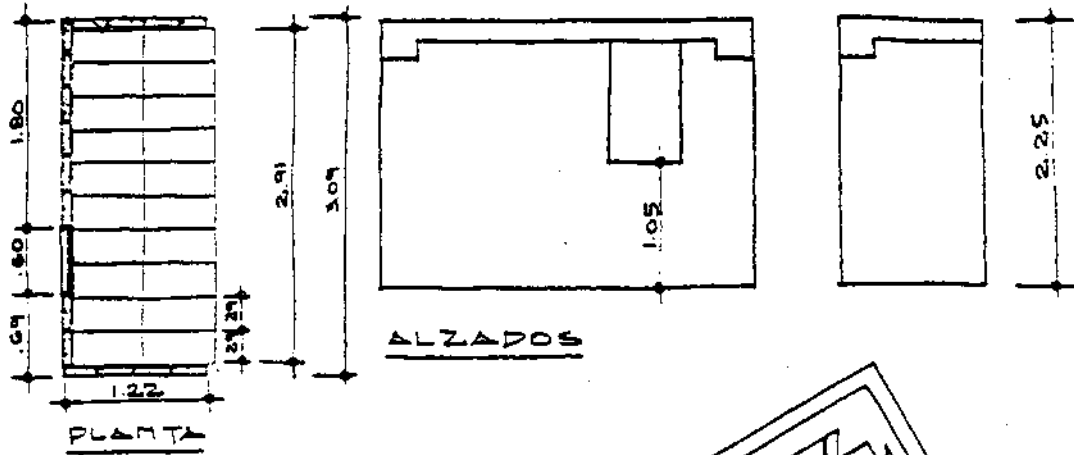

FIGURE 5.1 - The support system.

Moreno, Santiago. VIVIENDAS DE BAJO COSTO EN EL SECTOR INFORMAL - SEMINARIO INTERNACIONAL, 30-31 January - 1 February, 1985, Santo Domingo, Rep. Dom.

ESTRUCTURA BASICA.



1. VIGA DE AMARRE (EN CONCRETO)
2. BLOQUE CAVA-PAV.
3. VENTANA
4. LOSETAS PREFABRIC.
5. CEMENTO EN SUELO
CEMENTO

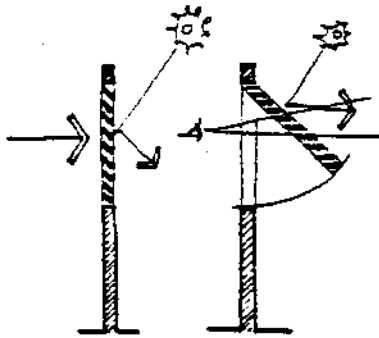

VENTANA

PERDANA DEBILITADA
EN TAZONADA PARA
PROTECCION SOLAR.

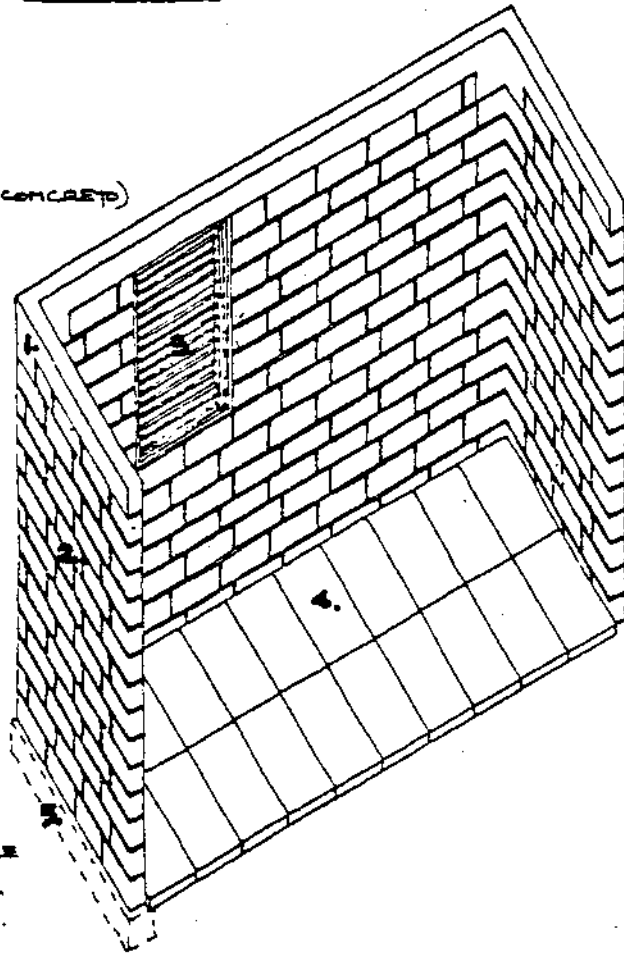
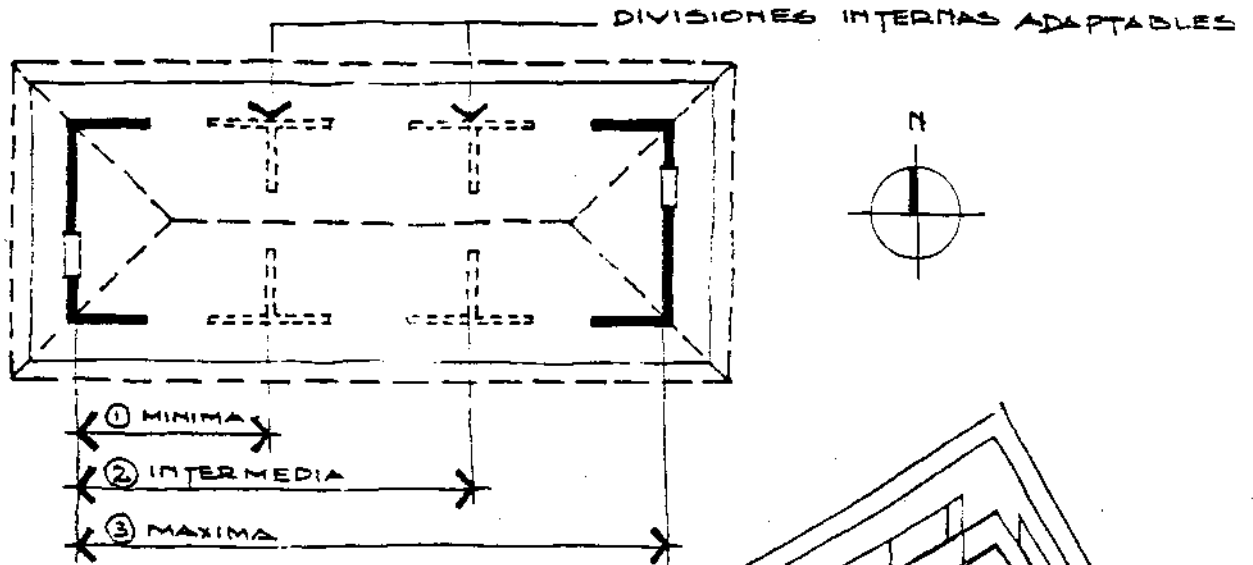

FIGURE 5.2 - The basic structure. Ibid.

UNIDAD DE HABITACION



ALTERNATIVAS

- ① UNA ALCOBA
- ② DOS ALCOBAS
- ③ DOS ALCOBAS Y ESTAR.

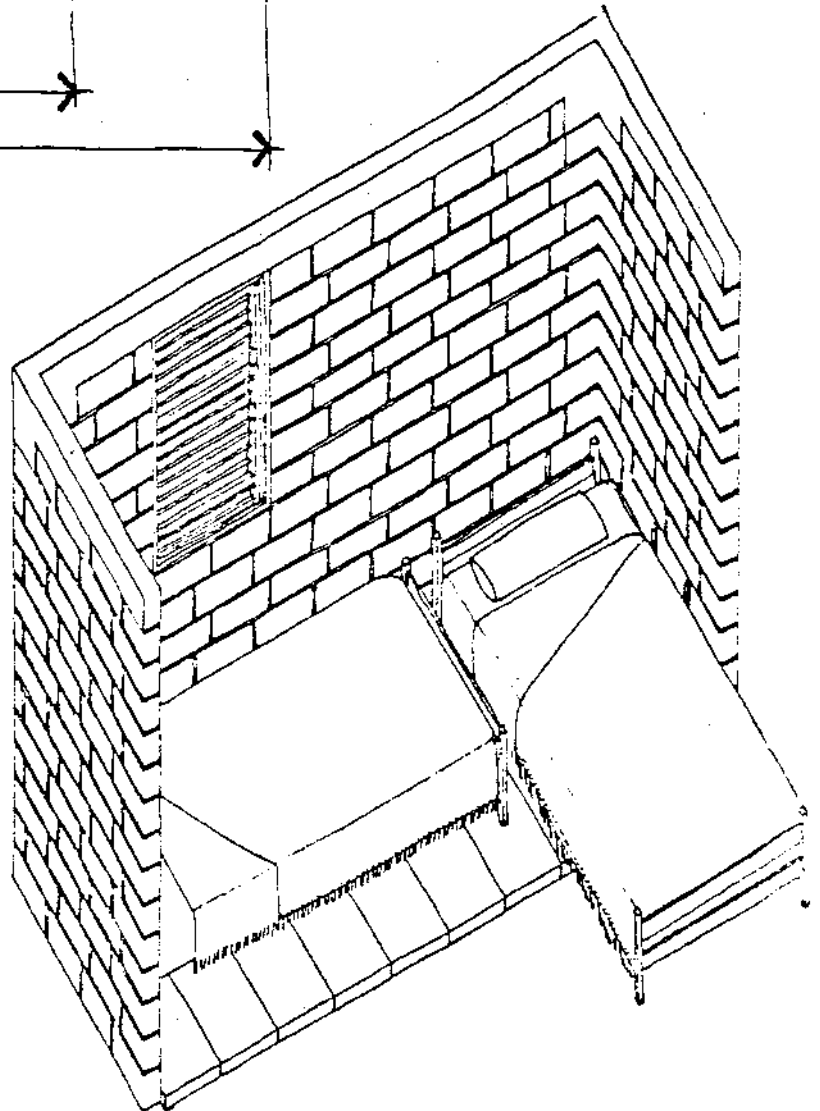
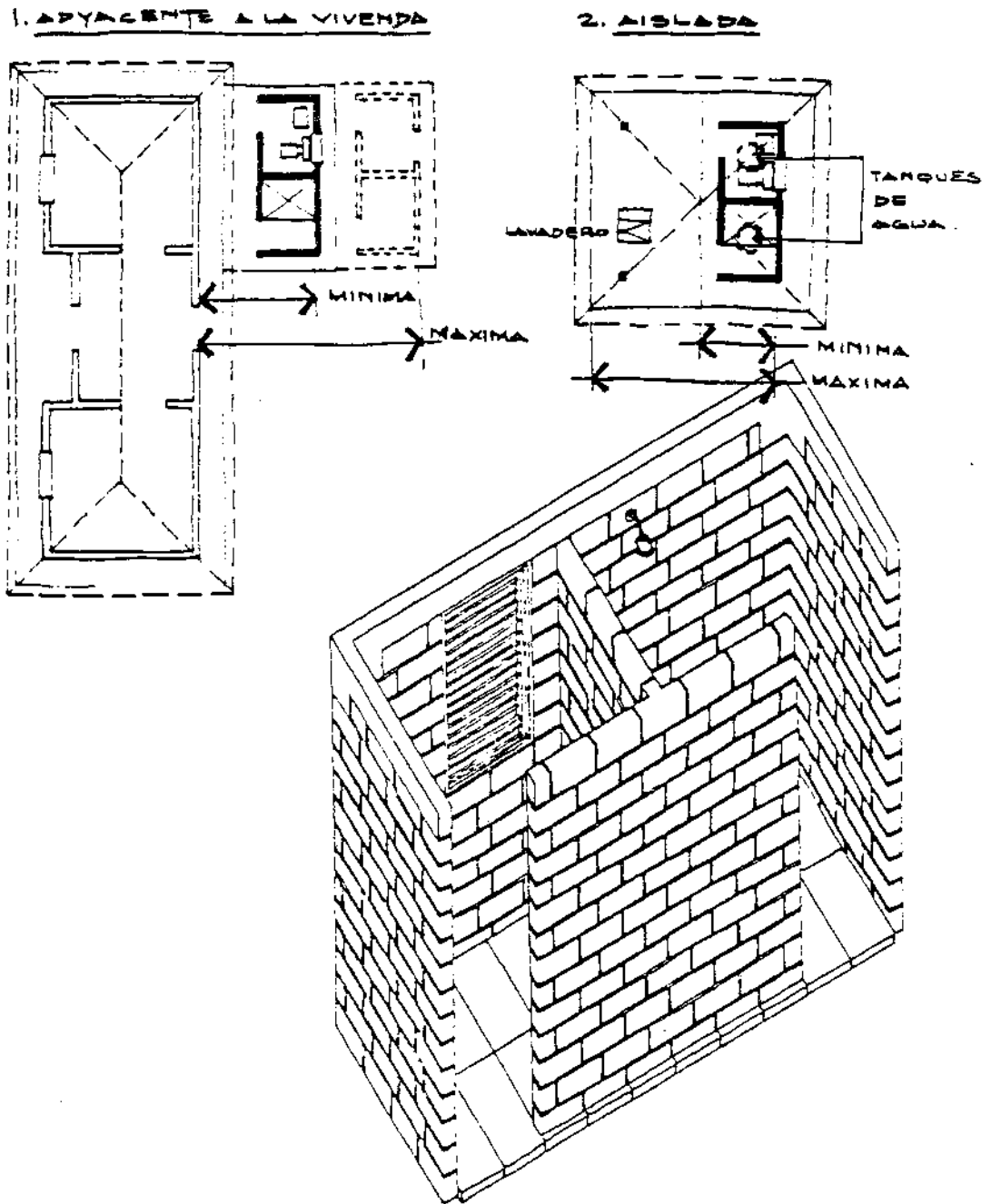

FIGURE 5.3 - The living Unit. Ibid.

UNIDAD DE SERVICIOS.



UNIDAD DE COCINA

1. ADYACENTE A LA VIVIENDA.

2. AISLADA.

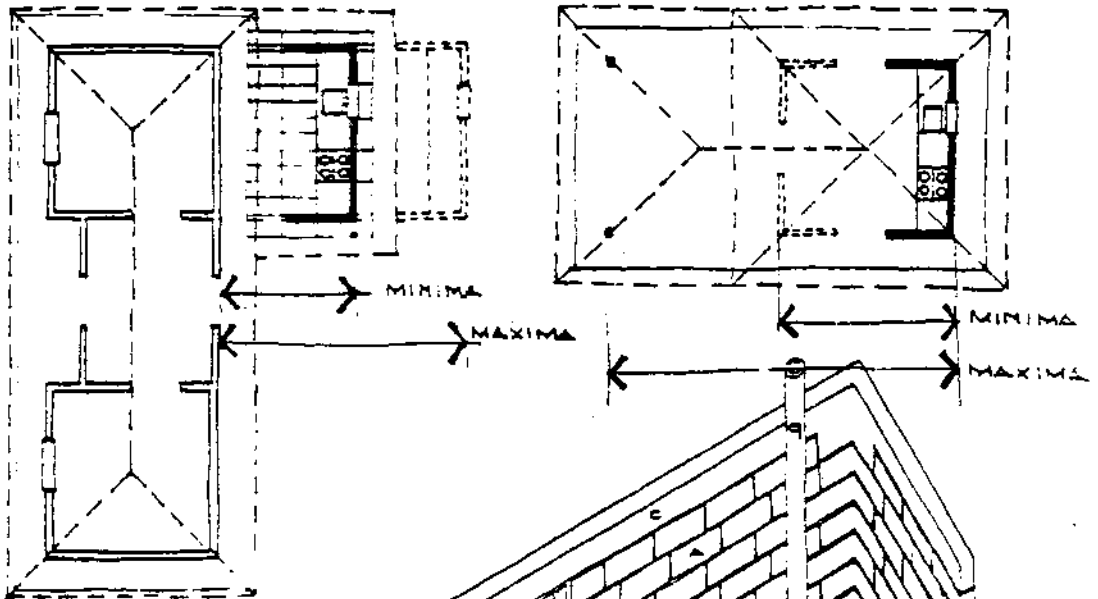

ELEMENTOS
CONSTITUTIVOS

- A. LADRILLO (UNVA-RAM)
- B. LOSETAS PRECAB.
- C. VIGA DE AMARRAR

- 1. ESTUFA AUTO-PURIFICANTE
- 2. DEPOSITO DE AGUA
- 3. AGUA HERVIDA
- 4. HORNO
- 5. LAVAPLATOS
- 6. DEPOSITO LEÑA
- 7. VENTANA CELOSIA.
- 8. MESON (LOSETAS PRECAB)
- 9. DESFOQUE ESTUFA.

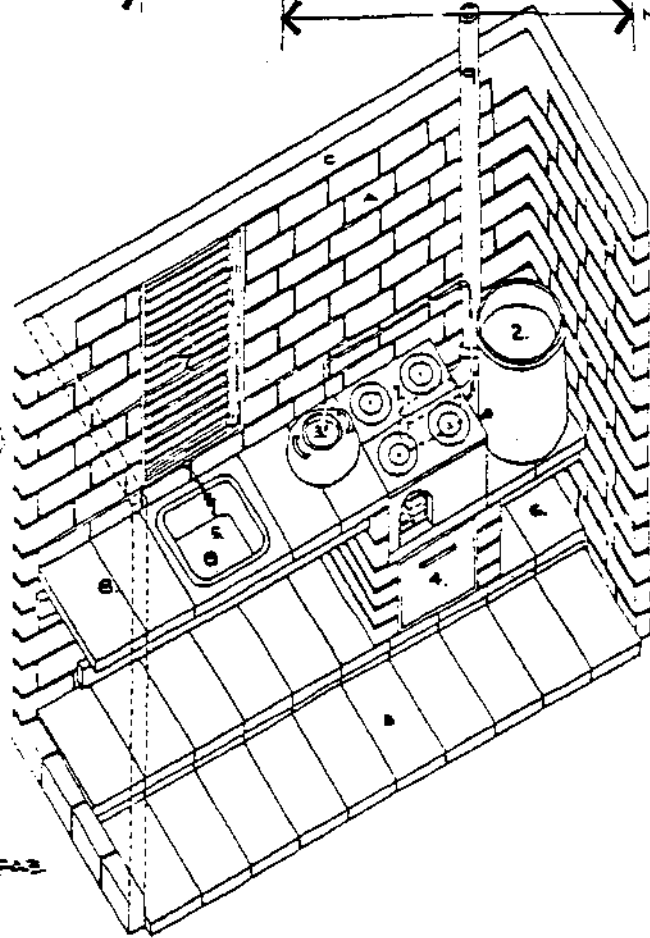
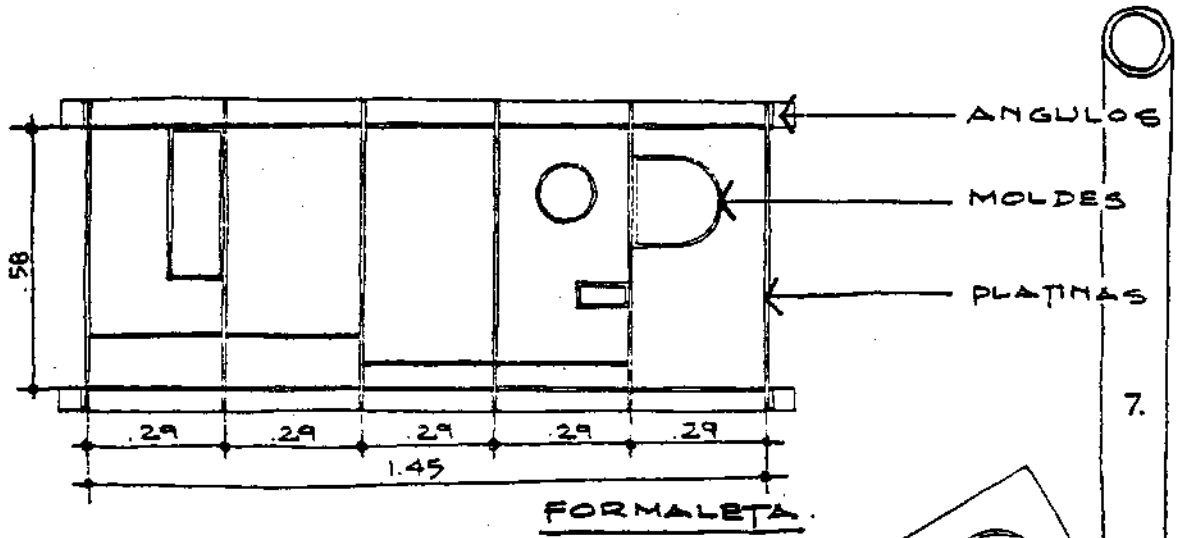
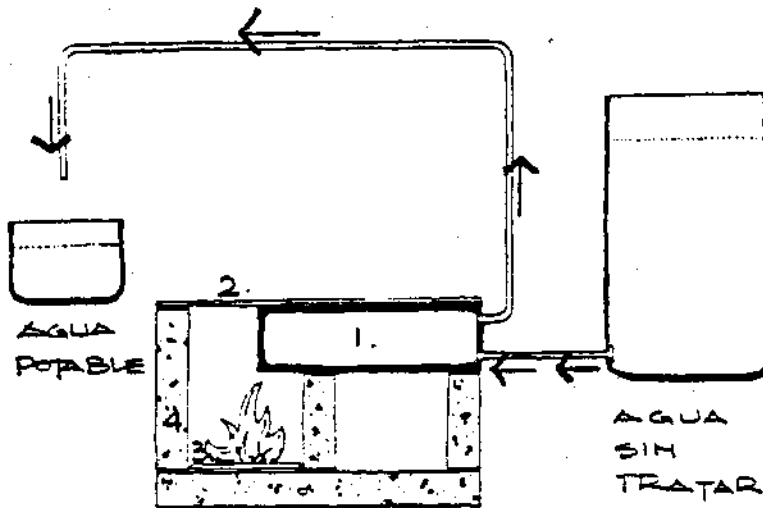

FIGURE 5.5 - The kitchen unit. Ibid.

ESTUFA 'CENTA' (MODIFICADA)



1. CALDERA
2. PLANCHAS METALICAS
3. PARRILLA
4. PREFABRICADOS
5. DESFOGUE
6. HORNO
7. DUCTO



PROCESO DE PURIFICACION DE AGUA

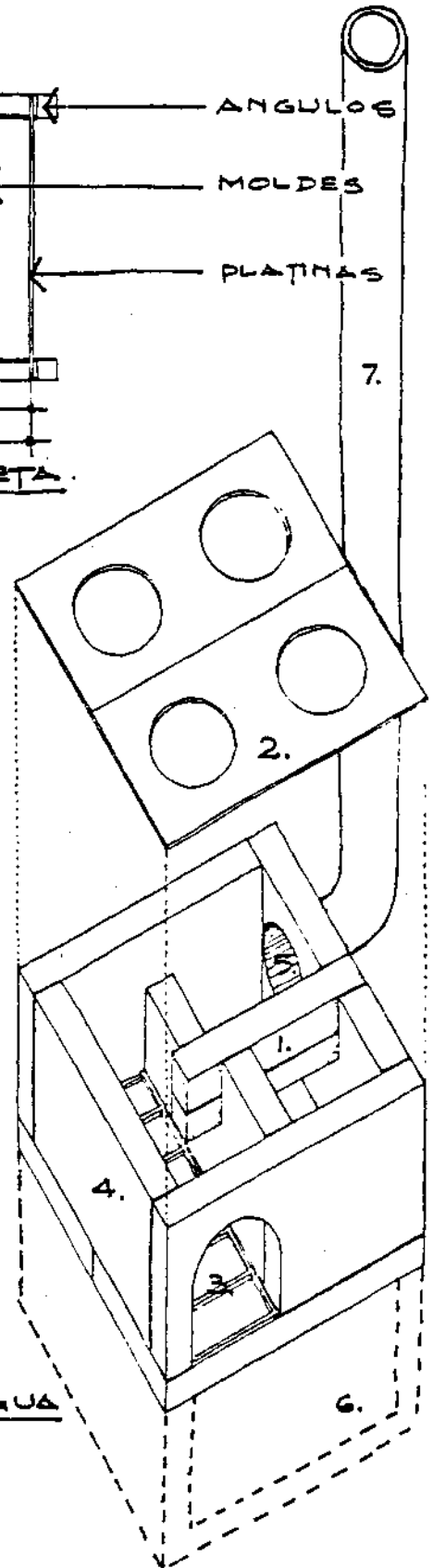

FIGURE 5.6 - Stove. Ibid.

POSIBILIDADES DE AGRUPACION.

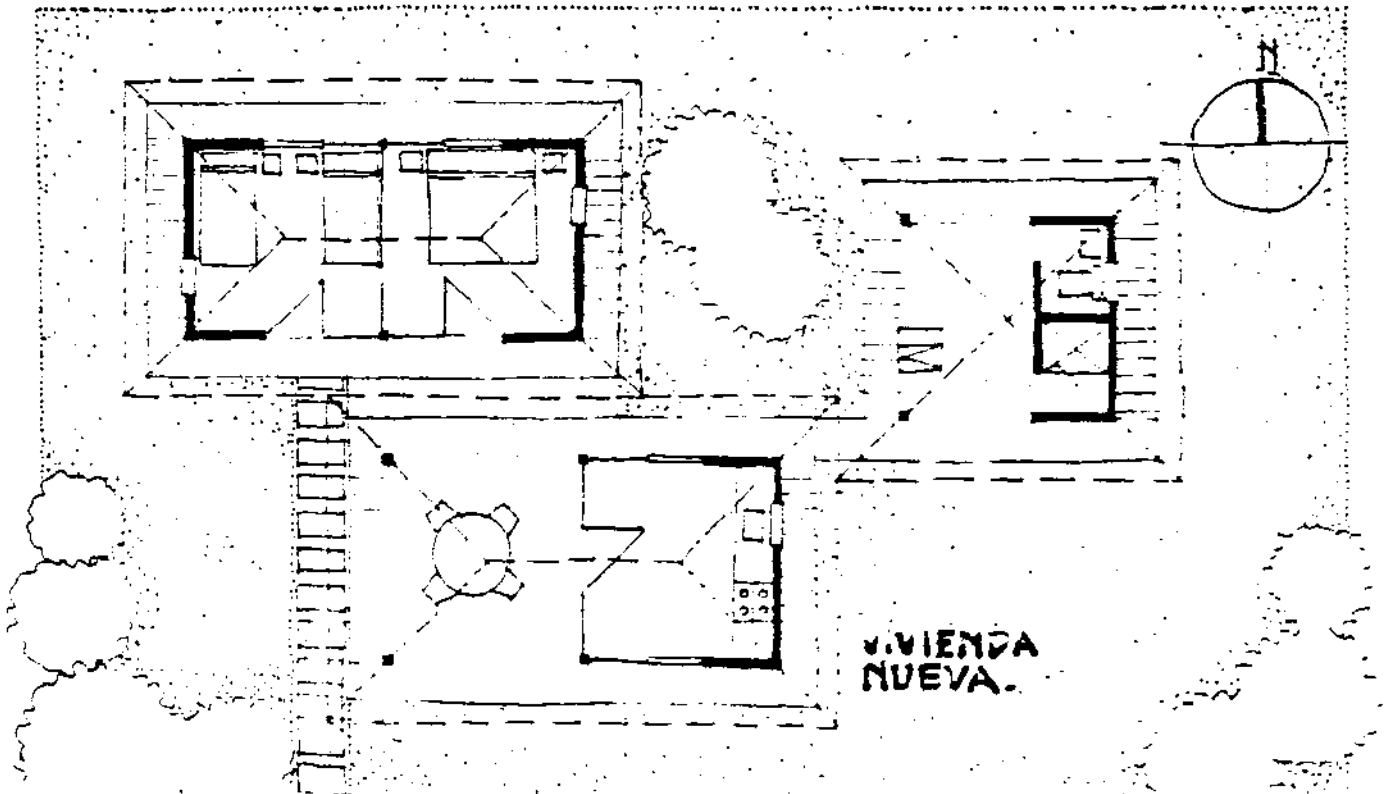
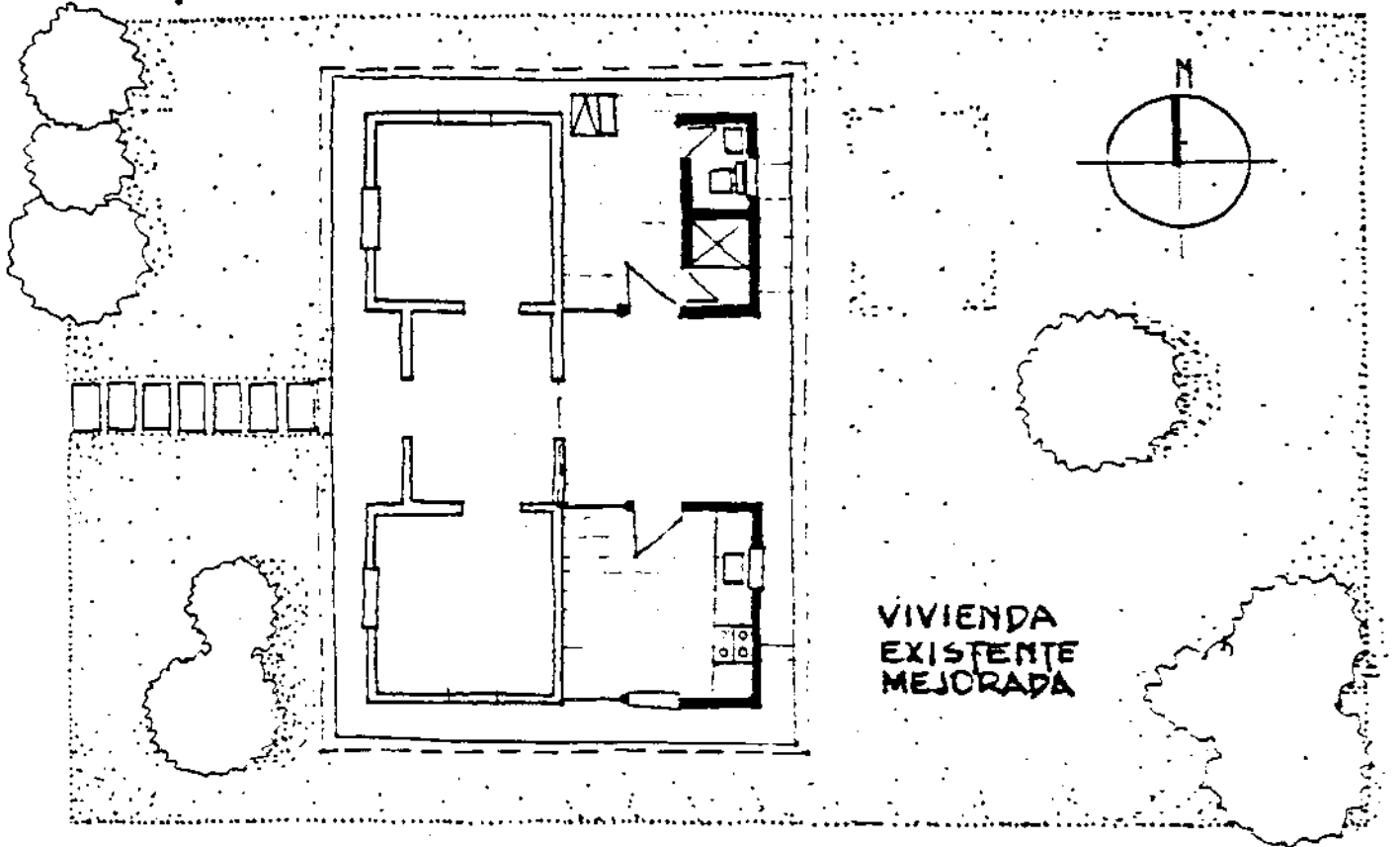

FIGURE 5.7 - Possible unit configurations. Ibid.

CONSTRUCTION MATERIALS FOR LOW-COST HOUSING:
THE TESTING AND PRODUCTION OF
FIBER-CEMENT ROOFING TILES

CETAVIP/CII-VIVIENDAS

The Dominican housing organization CII-VIVIENDAS in conjunction with a similar Dominican organization oriented towards the technical aspects of housing construction, CETAVIP, joint-tested fiber-cement tiles and revealed their results during the "Low-Cost Housing" seminar. Though the manufacture of fiber-cement tiles is relatively well-developed globally (figure 5.9 : " State of Development"), fiber-cement has only recently been introduced to the Dominican Republic as a roofing material. As a result, CETAVIP and CII-VIVIENDAS did not have long-term results of the material's performance but had for initial use, developed the optimal measurements for its mixture and dimensions.

FIBER-CEMENT MIXTURE

- SISAL FIBER (PALM)
- FINE SAND
- FIBER LENGTH: 2 to 3 cms.
- Porportion of cement to sand - CEMENT/SAND = 1.00
- " " fiber to cement + sand = 1.00%

DIMENSIONS

- LENGTH = 1.35 Mts.
- WIDTH = 0.75 Mts.
- THICKNESS = 9 Mms.

Pg.11. INVESTIGATION, ASISTENCIA Y TRANSFERENCIA TECNOLOGIA DE MATERIALS ALTERNOS: EXPERIENCIAS Y PERSPECTIVAS EN LA REPUBLICA DOMINICA, International Seminar on Low-Cost Housing in Santo Domingo, Dominican Republic - 30 January - 1 Febuary, 1985

Fiber-cement tiles proved to be the least costly of the manufactured materials for roofing in the Dominican Republic and has the added advantage that it can be manufactured on-site as well as off-site for considerably less cost than comparable roofing materials such as corrugated zinc, aluminum, asbestos cement and so on.

Though long-term observations as to fiber-cement's performance was unavailable at the conference, immediate problems were noted by the CETAVIP - CII-VIVIENDAS test team during the assembly process. The tiles were heavy and brittle. Attaching the tiles to the roof framing required rubber gaskets beneath the nail heads to prevent leaks and hairline cracks from developing. The rubber gaskets were found to decay rapidly in strong sunlight.

Supplemental Information on Fiber-Cement Tile -

The fiber-cement tile was originally developed by the I.T. Workshop C/O JPM Parry and Associates in Great Britain in 1977. The following information was made available in 1980 by I.T. Workshop describing the properties of fiber-cement tiles .

"ROOF SHEETS Work on evolving the best application for the fibre - cement roofing technology has resulted in the development of a sheet or panel designed to fit on a variety of roof structures.

The sheets can be made in two alternate forms; smooth side upwards with a highly reflective top surface, or with the trowelled face upward, so that the strengthening cross ribs provide an attractive tile-like effect.

Most fibre - cement sheets are now made in short lengths of one metre to accomodate irregularities which occur in many roof structures. Purlins out of line would break a single long sheet. But two short sheets can adjust at the overlap and avoid breaking.

COOLNESS An advantage with the use of the FRC sheets and ridge tiles is their coolness when compared, for instance, with corrugated iron. In most climates it will not be necessary to install a ceiling under an FRC sheet roof as the sheets provide both insulation and also ventilation between the joints and at the ridge.

STRENGTH The sheets can be made to specification. Where needed, greater strength can be achieved by increasing their thickness or the depth of the corrugations and cross ribs, or by using a higher cement sand ratio. For normal climates it is considered that a load carrying capability of 100 kg. at a point midway between the purlins will be adequate. In hurricane-prone areas it might be necessary to increase this minimum to 150 kg. Typical FRC roof sheets weigh 18 kg per sq.m. (4 lbs per sq. ft.)

STRUCTURES Although up to a third heavier than asbestos, FRC sheets do not demand any difference in roof structures as the main factor determining the design of these is not weight, but wind pressure which could amount to ten times any load put on a roof by the weight of the sheets themselves. Builders should use trusses made on a template to ensure that the purlins are accurately positioned. FRC sheets are not flexible and will crack if fixed irregularly.

MAINTENANCE The sheets are not especially resistant to impact from heavy falling or flying objects and where this occurs repairs will be needed for holes and cracks. This can be done in situ without actually removing the sheet, and it is even possible to undertake the repair from below, thereby avoiding having to climb on the roof. The repair is simple to carry out, the sheet surface around the crack is painted with PVA (white wood glue) and then a patch of fresh fibre-cement patted on by hand and left to set.

ECONOMICS The most important cost in producing the sheets is

cement. For normal applications with good sand it is often possible to produce standard duty sheets with as little as 8 kg. of cement. One bag of cement will therefore produce roofing cover up to 6 sq. m. (64 sq. ft.) Where heavy duty sheets are required, cement used may be as much as 12 kg. so that one bag will produce 4 sq. m. (43 sq. ft.) labour needed to run roof sheet plants is usually 4 men to make 20 items a day. For coating, allow about 1.5 manhours wages per sheet. Sand and fibre are not usually regarded as a significant cost factor. One kg. of fibre will normally produce 5 sheets and a ton of sand over a hundred sheets. IN TYPICAL APPLICATIONS ONE BAG OF CEMENT AND ONE MAN'S LABOR NOW MAKE FIVE ROOF SHEETS A DAY.

MAINTENANCE : 1) Replace tiles every 15 years. 2) Replace structure every 15 years.

MANUFACTURING/CONSTRUCTION PROCEDURE: Cement tiles are fabricated by mixing sand, cement, fiber and water. They are formed over an asbestos tile form. The structure is erected with 2x4 purlins. The cement tiles are either nailed or bolted to the purlins.

DESCRIPTION OF STRUCTURE: Heavy framing. The structure is constructed from #1 structural grade pressure treated 2x4 trusses. Purlins are 2x4's nailed to trusses @ 1 m. on center.

LOCAL ENVIRONMENTAL IMPACT: Local sand, appropriate natural fiber (coconut husk or banana fibers), and water are required to manufacture these tiles. Use of these materials would have little environmental impact. Coconut husk and banana fibers is in abundance in the (Dominican Republic.) They are also renewable resources.

THERMAL EFFECTS: Cement tiles will provide a small amount of daytime insulation. Tiles will radiate a small amount of heat. Whitewashing the roof every 2-3 years would significantly improve the thermal qualities of the tiles.

FLAMMABILITY: nonflammable-----flammable
 3 2 1 0 -1 -2 -3

INFESTATION POTENTIAL: none-----high
 3 2 1 0 -1 -2 -3

STATE OF DEVELOPMENT: developed-----undeveloped"
 3 2 1 0 -1 -2 -3

Pg.50-51, Florida A&M University School of Architecture, Experimental Low-Cost Construction Unit. INVESTIGATION OF ALTERNATIVE ROOFING SYSTEMS AVAILABLE FOR USE IN THE KURTUNWAARE PILOT HOUSING PROJECT, by D.T. Hollister and L.E. Birch, Publication No. 5, June 1981

BIBLIOGRAPHY

BOOKS, MANUALS & REPORTS

Abrams, Charles, MAN'S STRUGGLE FOR SHELTER IN AN URBANIZING WORLD, Cambridge Massachussetts, M.I.T. Press, 1970

Alexander, Christopher, THE TIMELESS WAY OF BUILDING, New York City, Oxford City Press, 1979

Alexander, Christopher, HOUSES GENERATED BY PATTERNS, Reprinted from ARCHITECTURAL DESIGN, April 1970, Berkeley California, Center for Environmental Structure, 1970

Ambasz, Emilio, THE ARCHITECTURE OF LUIS BARRAGAN, New York City, The Museum of Modern Art, 1972

Bahl, Dinesh, THE WORLD BANK & INTERNATIONAL FINANCE CORPORATION, second edition, Washington D.C., The World Bank, 1986

Balassa, Bela, TRADE BETWEEN DEVELOPED AND DEVELOPING COUNTRIES, THE DECADE AHEAD, Washington D.C., World Bank Reprint Series: No.321, 1984

Carreiro, Joseph (ed.) with Allen Bushnell, Joseph Koncelik, Charles Pearman, Howard Levirne, Steven Mensch, THE NEW BUILDING BLOCK: A REPORT ON THE FACTORY PRODUCED DWELLING MODULE, fifth edition, 1972

Cherner, Norman, HOW TO BUILD A HOUSE FOR \$6000: FABRICATING HOUSES FROM COMPONENT PARTS, New York City, Reinhold Publishers, 1968

Churchill, Anthony A., SHELTER : POVERTY AND BASIC NEEDS SERIES, SEPTEMBER 1980, Washington D.C., World Bank, 1980

Cii-Viviendas, RASUMEN SEMINARIO INTERNACIONAL: VIVIENDAS DE BAJO COSTO EN EL SECTOR INFORMAL, Santo Domingo, Republica Dominicana, Cii-Viviendas, 1985

Clarke, Robin, BUILDING FOR SELF-SUFFICIENCY: TOOLS, MATERIALS, BUILDING, HEAT, INSULATION, SOLAR ENERGY, WIND POWER, WATER & PLUMBING, WASTE & COMPOST, METHANE, TRANSPORT, FOOD, New York, Universe Books, 1976

Clausen, A.W., POVERTY IN THE DEVELOPING COUNTRIES, 1985, Address given at Martin Luther King Jr. Center, Atlanta, Georgia, January 11, 1985, Washington D.C., The World Bank, 1986

Dancy, Reverend Harold K., MISSION BUILDING, reprint: A MANUAL OF BUILDING CONSTRUCTION, London, Great Britain, Intermediate Technology Development Group Ltd., 1973

Eccli, Eugene, Ed., LOW-COST, ENERGY EFFICIENT SHELTER: FOR THE OWNER AND BUILDER, Emmaus, Pennsylvania, Rodale Press Inc., 1976

Eygelaar, J. ROOFS FOR LOW-COST STRUCTURES, Nairobi, University of Nairobi Housing Research and Development Unit, 1978

Follain, James R., with Gill Chin Lim, Renaud Bertrand, HOUSING CROWDING IN DEVELOPING COUNTRIES AND WILLINGNESS TO PAY FOR EXTRA SPACE: THE CASE OF KOREA, Washington D.C., World Bank Reprint Series: No. 269, 1982

Fry, Maxwell and Jane Drew, TROPICAL ARCHITECTURE: IN THE DRY AND HUMID ZONES, second edition, Malabar Florida, Robert E. Krieger Publishing Company, 1986

Fuller, Millard, BOKOTOLA, Chicago, Follett Publishing Company, 1977

Gomez, Carmen with Antonio Tatis, Nelson Ramirez, POBLACION Y VIVIENDA EN LA REPUBLICA DOMINICANA, DIAGNOSTICO DEL SECTOR VIVIENDA Y PROYECCION DE OFERTA VS. NECESIDADES EN ESTA AREA, 1985 - 2000, Santo Domingo, Republica Dominicana, Instituto de Estudios de Poblacion Y Desarrollo IEPD, 1984

Grimes, Orville F. Jr., HOUSING FOR LOW-INCOME URBAN FAMILIES: ECONOMICS AND POLICY IN THE DEVELOPING WORLD, Washington D.C., World Bank Research Publication, 1976

Hamer, Andrew Marshall, BOGOTA'S UNREGULATED SUBDIVISIONS: THE MYTHS AND REALITIES OF INCREMENTAL HOUSING CONSTRUCTION, Washington D.C., World Bank Staff Working Papers, No.734, 1985

Hornbostel, Caleb, CONSTRUCTION MATERIALS, TYPES, USES AND APPLICATIONS, New York City, Wiley Interscience Publishers, 1978

Huber, Benedict and Jean-Claude Steinegger, JEAN PROUVE : INDUSTRIAL ARCHITECTURE, Zurich, Switzerland, Architectur Artemis Zurich, 1971

Keare, Douglas H. and Emmanuel Jimenez, PROGRESSIVE DEVELOPMENT AND AFFORDABILITY IN THE DESIGN OF URBAN SHELTER PROJECTS, Washington D.C., World Bank Staff Working Papers, No.560, 1983

Koenigsberger, O.H., (ed.) and S. Groak, HABITAT INTERNATIONAL, vol. 5, No. 3/4, Oxford, Pergamon Press, 1976

Madhava Rao, A.G., (ed.) with Ramachandra Murthy, G. Annamalai, MODERN HOUSING TRENDS IN DEVELOPING COUNTRIES, New York City, E. & F.N. Spon Publishing Company, 1984

Malpazzi, Stephen and Stephen K. Mayo with David K. Gross, HOUSING DEMAND IN DEVELOPING COUNTRIES, Washington D.C., World Bank Staff Working Papers, No. 733, 1985

Marsden, Keith, SERVICES FOR SMALL FIRMS, THE ROLES OF GOVERNMENT PROGRAMMES AND MARKET NETWORKS IN THAILAND, Washington D.C., The World Bank, 1976

Nanita, Milagros and Patricia Klobus Edwards, DIFFUSION PROGRAM CENTER FOR APPROPRIATE TECHNOLOGY FOR POPULAR HOUSING - SECOND YEAR EVALUATION, Blacksburg Virginia, College of Architecture and Urban Studies, Virginia Polytechnic and State University, 1986

Oliver, Paul, SHELTER, SIGN & SYMBOL, Woodstock, New York, The Overlook Press, 1977

Office of International Affairs, Department of Housing and Urban Development, SPECIAL REPORT ON TECHNIQUES OF AIDED SELF - HELP HOUSING: SOME EXAMPLES OF U.S. AND OVERSEAS EXPERIENCE, Washington D.C., Housing and Urban Development (H.U.D.), 1973

Padco Incorporated in collaboration with World Bank staff, THE BERTAUD MODEL, A MODEL FOR THE ANALYSIS OF ALTERNATIVES FOR LOW-INCOME SHELTER IN THE DEVELOPING WORLD, Washington D.C., Urban Development Department, Technical Paper No. 2, World Bank, 1981

Papanek, Victor, DESIGN FOR THE REAL WORLD: HUMAN ECOLOGY & SOCIAL CHANGE, second edition completely revised, New York City, Van Nostrand Reinhold Company, 1984

Planning Office, Puerto Rican Urban Renewal and Housing Administration, INDUSTRIALIZED HOUSING SYSTEMS FOR PUERTO RICO, San Juan, Puerto Rico, Planning Office, Puerto Rican Urban Renewal and Housing Administration, 1968

Pneuman, Frederick C., RIGID FRAME JOINTS, LABORATORY REPORT 96, Tacoma, Washington, Applied Research Department, Division for Product Approval, American Plywood Association, 1976

Rad, Parvis F. (ed.) with Herbert W. Busching, J. Carl Johnson, Oktay Ural, PROCEEDINGS: IAHS INTERNATIONAL SYMPOSIUM ON HOUSING PROBLEMS - 1976, Atlanta, Georgia, Clemson University, May 24 - 28, 1976

Raeburn, Michael, ARCHITECTURE OF THE WESTERN WORLD, second edition, London, Great Britain, Orbis Publishing LTD., 1984

Rybcznsky, Witold (ed.), HOW THE OTHER HALF BUILDS, Vol. 1 & 2, Montreal, Canada, Centre for Minimum Cost Housing, McGill University, 1986

Saini, Balwant Singh, BUILDING IN HOT DRY CLIMATES, New York, John Wiley & Sons, 1980

Shapiro, Benjamin (ed.), A COMPENDIUM OF BUILDING SYSTEMS AND COMPONENTS, Washington D.C., National Association of Home Builders, National Housing Center Library, Classification No. 270.01, 1969

Sebestyen, Gyula, LIGHTWEIGHT BUILDING CONSTRUCTION, New York, John Wiley & Sons, 1977

Soleri, Paolo and Scott M. Davis, PAOLO SOLERI'S EARTH CASTING FOR SCULPTURE MODELS AND CONSTRUCTION, Salt Lake City, Utah, Peregrine Smith Books, 1984

The World Bank, LEARNING BY DOING - WORLD BANK LENDING FOR URBAN DEVELOPMENT, 1972 - 82, Washington D.C., The World Bank, 1976

The World Bank, MAKING THE MOST OF BUSINESS OPPORTUNITIES FROM WORLD BANK PROJECTS, second edition, Washington D.C., The World Bank, 1984

Turner, John F.C., HOUSING BY PEOPLE: TOWARDS AUTONOMY IN BUILDING ENVIRONMENTS, New York City, Pantheon Books, 1976

Turner, John F.C.(ed.) and Peter Grenell, FREEDOM TO BUILD: DWELLER CONTROL OF THE BUILDING PROCESS, New York City, Macmillan Publishing Company, 1972

United Nations, SEMINAR ON PREFABRICATION OF HOUSES FOR LATIN AMERICA, COPENHAGEN, DENMARK, New York City, United Nations, 1972

Ural, Oktay (ed.) HOUSING: PLANNING, FINANCING, CONSTRUCTION - PROCEEDINGS OF THE INTERNATIONAL CONFERENCE ON HOUSING, PLANNING, CONSTRUCTION, DECEMBER 2 - 7, MIAMI BEACH, FLORIDA, New York City, Pergammon Press, 1979

Ural, Oktay, CONSTRUCTION OF LOWER COST HOUSING, New York City, John Wiley & Sons Incorporated, 1980

U.S. Department of the Army, U.S. Corp of Engineers, MAINTENANCE AND REPAIR OF ROOFS, TM 5 - 617, Washington D.C., U.S. Army Corp of Engineers, October 1982

U.S. Department of Housing and Urban Development, Office of Policy Development and Research, HOME BUILDING COST CUTS, CONSTRUCTION METHODS AND MATERIALS FOR AFFORDABLE HOUSING, Washington D.C., H.U.D., 1986

BIBLIOGRAPHY - ARTICLES

Blair, Thomas, " Problem Cities: Cairo ", ARCHITECTURAL ASSOCIATION QUARTERLY, Vol.12, No.1, 1980

Bourdier, Jean - Paul, " Genius Before Industry: Vernacular Architecture of the Gurundi " PROGRESSIVE ARCHITECTURE, 8 - 1982

Bourdier, Jean - Paul, " Low - Cost Housing in Mauritania " PROGRESSIVE ARCHITECTURE, 7 - 1984

Burns, Leland S., " Third World Models for Helping U.S. Homeless " THE WALL STREET JOURNAL, January 2, 1986

Callaway, Thomas R., " Thatching ", The Office of International Affairs, Department of Housing and Urban Development (H.U.D.), 1964

Fisher, Thomas, " Instant Housing " PROGRESSIVE ARCHITECTURE, 7 - 1984

Hall, Peter (ed.), " Theme: Housing Alternatives: Third World " BUILT ENVIRONMENT, Vol.8, No.2, 1982

Hira, B.N., " L - Pan Roofing " BUILDING TECHNIQUE SERIES, No.10, Central Building Research Institute (C.B.R.I.), Roorkee, India, 7 - 1978

Knauer, Bent, " Industrialized Building in Developing Countries " BUILDING RESEARCH AND PRACTICE, 8/9 - 1982

Lewcock, Ronald, " The Need for Special Studies of Problems of Third World Architecture " ARCHITECTURAL ASSOCIATION QUARTERLY, Vol.2, No.1, 1980

Meyer, John A., " Wood - Polymer Materials: State of the Art " WOOD SCIENCE, Vol. 14, No. 2, 1982

Meyer, John A., " Industrial Use of Wood Polymer Materials: State of the Art " FOREST PRODUCTS JOURNAL, Vol. 32, No. 1, 1982

Meyer, John A., " Making Wood Plastic Using Catalyst - Heat Techniques ", State University College of Forestry at Syracuse University, 1966

Mpolokoso, Elpidius, " Zambia: The Need for a Training and Research Center for Human Settlements Development " ARCHITECTURAL ASSOCIATION QUARTERLY, Vol. 12, No. 1, 1980

Oesterich, J. " Positive Policies Towards Spontaneous Settlements " EKISTICS 286, 2 - 1981

Rowntree, Diana, " Western Lessons " THE ARCHITECTS' JOURNAL, Vol.177, No. 17, April 27, 1983

Spence, Robin, " Laurie Baker: Architect for the Indian Poor " ARCHITECTURAL ASSOCIATION QUARTERLY, Vol.12, No. 1, 1980

United Nations Development Programme, Division of Information, " Shelter for the Homeless - A Theme for 1987, A Goal for the Year 2000 " UNDP DOSSIER, 1987

World Health Organization, " Shelter & Health ", World Health Organization (W.H.O.), International Year for the Homeless, 1987

BIBLIOGRAPHY - THESES

Iyortyer, Philip Zegetar, TROPICAL URBAN HOUSING DESIGN CONSIDERATIONS WITH SPECIAL REFERENCE TO NIGERIA, Montreal, Canada, McGill University, 1982

Mueller, Martin V., LOW - COST ROOFING SYSTEMS FOR DEVELOPING COUNTRIES, Montreal, Canada, McGill University, 1982

Wright, Millard M., SHORT - SPAN ROOFING SYSTEMS FOR POTENTIAL USE WITH HOUSING UNITS IN THE KURTUNWAARE SETTLEMENT PROJECT, Tallahassee, Florida, Florida A & M University, 1978

BIBLIOGRAPHY - ENCYCLOPEDIAS AND DICTIONARIES

Greenwald (ed.), MCGRAW - HILL DICTIONARY OF MODERN ECONOMICS, third edition, New York City, McGraw - Hill Book Company, 1983

Harris, William H. and Judith Levey, THE NEW COLUMBIA ENCYCLOPEDIA, New York City, Columbia University Press, 1975

Kuper, Adam and Jessica (ed.), THE SOCIAL SCIENCE ENCYCLOPEDIA, Boston, Massachusetts, Routledge and Kegan Paul, 1985

Osmanczyk, Edmund Jan, THE ENCYCLOPEDIA OF THE UNITED NATIONS AND INTERNATIONAL AGREEMENTS, Philadelphia, Pennsylvania, Taylor and Francis, 1985

GLOSSARY

DEVELOPING NATION - A nation whose people are beginning to utilize available resources in order to bring about a sustained increase in per capita production of goods and services. In general, a developing nation is a country that is capable of greater substantial improvements in its income level and is in the process of achieving these improvements.

- Pg.133, McGRAW-HILL DICTIONARY OF MODERN ECONOMICS
3rd Ed., McGraw-Hill Book Co.
Greenwald & Associates, N.Y.C., 1983

DEVELOPMENT STUDIES - The concept of development, like its kindred notions of growth and modernization, has its historical and intellectual roots in the period of major social changes associated with the Industrial Revolution, or what Kumar (1978) has called the 'Great Transformation', when industrial and social change in Europe became synonymous with social progress. Throughout the century that followed, and often in the face of strong countercurrents challenging this simple orthodoxy (Kitching, 1982), development in the eyes of most people (experts and laymen alike) came to be identified with some kind of stage-by-stage movement towards more 'modern', technologically and economically 'advanced' forms of society such as industrial nations.

By the mid-twentieth century the dominant image of social change was modernization, the process by which so-called traditional social structures are transformed into those of a more modern type, along the lines of what happened at an earlier stage in Europe (Smelser, 1963; Smith, 1973). Following the Second World War, the industrial nations, and especially those with colonies or ex-colonies, were increasingly confronted with the economic and political problems of the poorer nations. This led to a greater awareness of the need to devise strategies aimed at alleviating the poverty and raising the living standards of the populations of these more 'backward' countries. Development policies therefore stressed the importance of expanding production and modernizing the physical and social infrastructure. Development aid, of course, often indirectly benefited the Western nations as much as it did the recipients. This interest in modernization was quickly translated into a new field of study gradually calling itself development studies, an interdisciplinary grouping of subjects focusing upon the analysis and solution of problems of development, particularly those faced by the poorer, so-called developing countries. The types of disciplines brought together in this way included economics,

geography, political science, public administration, sociology, and anthropology; and they were sometimes joined by more technical subjects, such as agronomy and irrigation or civil engineering. Despite their differences in scientific interest and specific policy recommendations, they all, in the 1950s and early 1960s, shared a general belief in the efficacy of Western technological, economic and managerial practice for solving development problems. Even the anthropologists, whose professional expertise rested upon the elucidation of non-Western modes of behaviour and rationality, accepted, explicitly or implicitly, the modernization model when they sought to identify sociocultural obstacles or facilitating factors that might block or promote technological and economic change (Foster, 1962; Long, 1977).

By the mid-1960s, the stage was set for the establishment of a number of departments and special institutions which would provide the main scientific arena within which relevant development issues would be debated and investigated from both a theoretical and policy point of view. For example, the Institute of Development Studies at Sussex was founded in 1966, and the Overseas Development Group (later to form part of the School of Development Studies) at the University of East Anglia in the following year. However, almost as soon as development studies, with much promise, gained a foothold in academia, so it entered a period of growing uncertainty in development-policy thinking and in existing theories of development and social change (Myrdal, 1968; Seers, 1969). The credibility of simple growth and modernization models was shaken by the evident high environmental and human costs of such policies and by widening gap in per capita incomes between the rich and poor nations and between classes within the developing countries.

Hence, by the late 1960s and early 1970s, the field had become a rather untidy collection of competing theoretical paradigms and policy objectives. This situation resulted in part from the devastating critiques of modernization theory mounted by the 'dependency' and 'underdevelopment' writers ('Frank, 1967; Dos Santos, 1973) who argued that it was impossible to understand the processes and problems of development without locating them within the wider sociohistorical context of the expansion of mercantile and industrial capitalism to the poorer, more 'peripheral', countries. They sought to demonstrate that the fundamental problems facing the developing countries were a consequence of the emergence of this international system of economic and political domination. Genuine solutions to the problems of 'underdevelopment', then, would only come when the basic social contradictions inherent in structures of dependency were resolved 'in favour of the popular forces' (Salinas, 1977). At the same time, certain 'liberal' planners

injected into the discussions of policy and strategy questions of income redistribution, equity and participation. Many development specialists now argued that the transfer of technology and organizational structures, together with economic growth strategies, were inadequate for tackling the fundamental problems of poor economic performance coupled with maldistribution of income and resources (Chenery et al., 1974).

These radical and liberal criticisms of modernization theory and policy destroyed the earlier coherence of development studies. By the 1980s, we find no real consensus about the major analytical issues to be explored, nor how to go about solving practical problems of development. A healthy scepticism prevails about the idea of progressive development, a scepticism which is reinforced by the global ecological and military threat and by the world economic recession. Development can no longer be regarded as a relatively self-generating process set off by the implantation of modern technology and values. There is also, nowadays, a more explicit awareness of the essentially political and ideological nature of development: formulating goals and means for societal change (whether from the point of view of the central planner or citizen) necessarily entails value commitments and choice. Development studies therefore can no longer be monopolized by economic, technological and administrative types of argument but must take serious account of opposing ethical, political and cultural evaluations.

Development, then, is a concept with different implications depending upon the point of view of the user. It is possible, because of its association with ideas of developmentalism and evolutionist thought, that it may be replaced by some other concept (Nisbet, 1970). However, the kind of problematic it deals with - namely the analysis of societies at critical junctures of social transition - will remain an important area for enquiry, reflection and social action. Development studies will continue to play a role in providing an important arena within which this debate can take place.

Development studies remains torn between, on the one hand, relatively detached (though possibly policy-relevant) scientific analysis and, on the other hand, a commitment to engaging in the practical business of solving concrete problems. It also faces the problem of bringing together disciplines whose theoretical interests, methodologies, epistemologies, and scientific milieux are strikingly different. It frequently gives insufficient emphasis to understanding what different development processes mean to individuals in the pursuit of their everyday lives: there is a tendency to concentrate upon macrostructural aspects to the neglect of microprocesses that provide important

insights into the changing human condition in the contemporary world.

-Pg.198, Norman Long

THE SOCIAL SCIENCE ENCYCLOPEDIA

Ed. Adam Kuper & Jessica Kuper

Routledge & Kegan Paul, Boston Mass., Co. 1985

THIRD WORLD - The division of the world into three categories is a very popular device among social scientists, and especially economists and sociologists of development. The distinction derives from a United Nations classification system, which distinguishes between developed, free market economies (The First World), centrally-planned economies (the Second), and undeveloped, free market economies (the Third). The criteria for this classification are an awkward mixture of economic and political indices, easier to describe than to define (or to defend). Western European countries, the United States of America and Japan, clearly fall into the First World; all socialist countries clearly fall into the Second; and the Third World is therefore a residual category which includes the very rich (such as Kuwait), the very poor (such as Bangladesh), some very complex (such as Brazil), and some starkly simple economies (such as Paraguay). Reduced to its simplest terms, the Third World consists of economies which are neither fully industrial nor centrally planned; this definition permits the inclusion of a great range, not only of economic, but also of social and political conditions.

Arbitrary as it may seem, the division has proved highly durable. All those economies which now belong to the First World were already relatively industrialized by the outbreak of World War I, when an invisible door was slammed in the face of all economies which had not yet achieved some measure of industrial sophistication. Many settler societies (notably Australia, New Zealand, Canada, Argentina, Uruguay, and perhaps Israel) have often enjoyed higher incomes per capita than Western European societies; but in spite of the availability of capital, skilled manpower, and natural resources, none has broken through to the charmed circle of industrial maturity. They commonly perceived the United States as the development model to follow, and therefore adopted essentially laissez-faire strategies. Japan has been the equally compelling model for several Asian governments, which have striven for industrialization through encouragement of industrial capital and the coercion of a domestic labour force. Brazil, Iran, South Africa, South Korea, and Taiwan are among the more 'arresting' instances of this strategy; and thus far the appalling human cost have not been matched by

redeeming economic performance.

The term Third World is not only arbitrary: it is also pejorative. Nobody believes that the conditions it describes ought to be permitted. Where differences of opinion occur, they are about prescribing how the conditions are to be abolished. Economists commonly emphasize specific measures which individual governments might adopt, with a view to increasing national income or promoting industrial production. Sociologists and political scientists commonly insist that political and social reforms of various kinds must precede any major transformation of economic conditions. In point of fact there must be some question as to the ability of the world's resources, however benignly controlled, to sustain the level of industrial production which universal industrialization implies. If that doubt is valid, then the transformation of the First World may be as urgent as the abolition of the Third. In any event, this arbitrary, pejorative, and thoroughly irritating term seems destined to enjoy a long life, since the conditions it describes are evidently profoundly entrenched in the political, social and economic structure of the contemporary world.

- Pg. 856, Donald Denoon, IBID.

UNDERDEVELOPMENT - The original meaning of underdevelopment was a neutral one, simply defining the condition of poorer countries which then were called underdeveloped countries. However, this term was felt to be derogatory and has since disappeared from the international vocabulary, being replaced by the more euphemistic 'developing countries'. As a result the term underdeveloped has now assumed a specific and rather different meaning. It is now closely associated with the so-called dependency school, and it indicates a belief that in the world economy there are centrifugal forces at work, strengthening the position of the already rich 'core' while keeping the 'periphery' poor and in a state of permanent underdevelopment. The chief author using and building on this term was Andre Gunder Frank. Frank was also the first to speak of 'development of underdevelopment', meaning the development of a rich country/poor country or core/periphery relationship which results in the impoverishment of the poor or periphery partner.

There are a number of variants within the underdevelopment school. These range from the radical wing which identifies underdevelopment with neocolonial relationships and is an outgrowth of Marxist thinking, to nonpolitical or non-ideological explanations such as the principle of 'cumulative causation' developed by Gunnar

Myrdal. The principle of cumulative causation states that in the case of poor countries or poor groups a vicious circle is at work keeping them poor (for example, low income causing low savings and low investment, in turn causing low income in the next round; or low income leading to poor health leading to low productivity and low income). By contrast, in rich countries, or among rich groups, a reverse beneficial circle enables them to go from strength to strength and to improve their condition progressively. The strict Marxian view is perhaps best represented by W. Rodney in *How Europe Underdeveloped Africa* (1972): "An indispensable component of modern underdevelopment is that it expresses a particular relationship of exploitation: namely the exploitation of one country by another." This view logically also leads to the use of the concept in describing domestic relations within developing countries (as in relations between an urban elite and the rural poor), but in practice the term is now associated with an international context of relations between countries. In between these two extremes are various other schools of thought explaining that the system of international trade relations has a tendency to benefit rich countries more than poor countries. The best known of these schools is the Prebisch-Singer theory according to which the terms of trade of primary products tend to deteriorate in relation to the prices of manufactured goods (Prebisch, 1964; Singer, 1950).

The radical view that any international contact between rich and poor countries will be to the disadvantage of the latter, obviously leads to the policy conclusion that poorer countries should either try to be self-sufficient or inward-looking in their development; while in the case of smaller countries, where this is not feasible, regional groupings of developing countries are advocated. One does not have to be an advocate of the underdevelopment school, however, to support such policies; it is clear that trade, investment and other economic relations among the developing countries are conspicuously and abnormally sparse compared with relations between rich and poor countries. It can be argued that it is also in the interest of the richer industrialized countries to support such closer South-South co-operation.

The milder variation is that international contacts are advantageous for both partners, in accordance with liberal doctrine and the law of comparative advantage, but that the benefits are unequally distributed.

The belief of the more radical underdevelopment school that international relations are positively harmful to the poorer partners can in turn lead to two different policy conclusions. One is to reduce North-South contacts and instead develop South-South relations; the other is to reform the international system so that its benefits are more equally distributed. The latter approach is implied in

the pressure of the developing countries for a New International Economic Order which has dominated the international discussions during the last decade, and also in such reform proposals as the two Brandt Reports (Brandt I, 1980; and Brandt II, 1983).

- Pg.873, H.W. Singer, IBID.

UNDERDEVELOPED NATION - A country in which per capita income is relatively low compared with the per capita real incomes of industrial nations. Thus, an underdeveloped nation is a relatively poor country with per capita income under \$1,000, or less than one-tenth that of the United States. In general, there are several characteristics that are indicative of an underdeveloped area: (1) A very high proportion of the population is engaged in agriculture (usually between 70 and 90 %). (2) There is evidence of considerable disguised unemployment and a lack of employment opportunities outside agriculture. (3) There is very little capital per individual, and the condition of low per capita income requires existence at near - subsistence level. (4) For the large mass of people, saving is practically nonexistent, while the savings that do exist are accumulated by the land-holding class and do not further industry and commerce.

- Pg. 478, McGRAW-HILL DICTIONARY OF MODERN ECONOMICS

Policies of Development:

ABSTENTION - This emphasizes "laissez - faire" as the best means for encouraging development. Examples are allowing a builder to put up what he chooses, and giving industry free rein to settle where it wishes, and determine the hours and pay of its labor.

PERSUASION - This implies an appeal to industries or developers to do something they would ordinarily not do. In India, for example, large concerns have been persuaded to make social contributions that most industries concerned solely with self-interest would normally refuse. In the United States and England, capitalists may be persuaded to go into nonprofit or limited - profit enterprises or even subordinate the profit motive in an emergency.

REGULATION - This refers to restrictions by government in the interests of health, welfare or safety. It is the most tempting power in the government's arsenal since it entails no budgetary outlays, but it can cripple incentive and investment if used to excess. The regulative power may also be relaxed to stimulate private operations.

INDUCEMENT - This implies giving concessions in one form or another to lead to a desired action. Such concessions include subsidies, guarantees, loans, favorable tax policies, tariffs, and other aids to stimulate investment or venturing. Government mortgage insurance and free factory sites are examples.

DIRECT OPERATIONS - These include the building of roads, schools, and the like, but they may also embrace a wide variety of operations in one country that are left to private investment in another. When direct operations are very extensive, they identify the system as socialist, state-capitalist, or a related type of authoritarian government.

DESOCIALIZATION - This may occur in the sale or disposition of a socialized or government-owned asset, property or enterprise. Sale of government lands to encourage settlement is an example.

PUBLIC-PRIVATE JOINT VENTURES - Here the government may join through investment or credit in an undertaking with a private enterprise. The voluntary Home Mortgage Credit Program in the United States and mixed investment mortgage banks are examples.

REGULATED MONOPOLY - In this case, the government grants or tolerates exclusive control of a service but supervises it as a condition of the franchise. A franchise to a telephone company in Latin America or to a cement manufacturer in

Jamaica is an example. Monopoly can be consistent with free enterprise if the monopolized activities are carefully selected and regulated in the public interest.

PLANNED INEVITABILITY - Here the government plans the installation of roads, power or other works so that the site becomes the logical and even inevitable locus of development for industry, private housing, or other operations. This can be a useful device for planning industrial estates or for influencing settlement in a new town.

COOPERATIVE or NONPROFIT ENTERPRISE - Here the government may stimulate or create types of ventures with a philanthropic or public aim or one in which the profit motive is subordinate to general or cooperative good. There are many types of cooperatives, of which credit associations, housing cooperatives, self-help, agricultural and consumers cooperatives are few. The forms of nonprofit ventures are also varied. The most recent example in housing is the nonprofit housing enterprise sponsored by religious, social, and even private venturers in the United States (under section 221 (d) (3) of the 1961 Housing Act). Inducements of various kinds may spur the formation of cooperative or nonprofit associations.

Pg.s 216 - 218, Charles Abrams,
MAN'S STRUGGLE FOR SHELTER IN AN URBANIZING WORLD
M.I.T. Press, M.I.T., Cambridge, Mass., Co. 1970

**The two page vita has been
removed from the scanned
document. Page 1 of 2**

**The two page vita has been
removed from the scanned
document. Page 2 of 2**

LOW-COST HOUSING FOR DEVELOPING COUNTRIES:
AN ANALYSIS OF THE DESIGN PROCESS

by

Lawrence Miladinovich Shoup

Committee Chairman: Frederick Krimgold
Architecture

(ABSTRACT)

The subsequent data, analysis and case study is an attempt to clarify architectural approaches to meeting housing shortages in developing nations. This thesis is directed towards providing a greater understanding of the Third World building environment by examining unforeseen constraints, design parameters and the architect's new role vis-a-vis housing design for developing countries, as well as design approaches and strategies related to the housing problem in the developing world. These aspects of low-cost housing design in developing nations have been distilled into a process of design which is intended to further define a direction an architect can pursue in order to arrive at a feasible design solution regarding low-cost housing in developing countries. As a conclusion, the thesis provides a frame of reference to the previous analysis with a case study of the Dominican Republic, describing the country itself, its housing problem and some design proposals put forward by regional architects as a part of an international seminar on housing sponsored by the Dominican housing organization, CII-VIVIENDAS.

Chapters one, two and three approach the topic of low-

cost housing in developing countries as an analysis of the broadest architectural considerations.

Chapter one, "Design Constraints for Low-Cost Housing in Developing Countries" introduces the initial design considerations of building conditions in the developing world from the perspective of an architect trained in the construction practices of the more advanced industrial nations. In comparison to the conventional architectural environment of the developed nations, the limited construction resources of developing nations constitute severe building constraints. These constraints are examined.

Chapter two, "Summary of Design Parameters for Developing Countries" derives design guidelines from the architectural constraints of chapter one.

Chapter three, "Housing Design for Developing Countries: New Architectural Roles, New Design Approaches & New Design Process" supplements the analysis of the first two chapters with a review of current architects' design responses to the rigid building parameters inherent in low-cost housing design for developing countries.

Chapter four, "A Case Study of the Dominican Republic: Country & Housing Characteristics" provides a frame of reference for the previous analysis with information concerning the country, the architectural influences and the housing data of the Dominican Republic. The Dominican Republic suffers from housing problems typical to most

developing countries.

Chapter five, "Dominican Low-Cost Housing Seminar: Possible Low-Cost Housing Solutions for the Dominican Republic" concludes the thesis with a synthesis of the analysis and the case study. The synthesis is presented in terms of the diverse solutions to the housing shortage of the Dominican Republic reached by the participants of a low-cost housing seminar in the Dominican Republic. The seminar held in the winter of 1985 included foreign participants from both developed and developing countries in addition to the native Dominican participants. The design options described at the conclusion of chapter five are reflective of the current paths of low-cost housing development.