

Akinyode, Babatunde Femi; Jelili, Musibau Omoakin; Odunola, Olaitan Olutayo

## Article

# Structural equation modelling of users' assessment of affordable housing in developing cities

Economic and Environmental Studies (E&ES)

## Provided in Cooperation with:

Opole University

*Suggested Citation:* Akinyode, Babatunde Femi; Jelili, Musibau Omoakin; Odunola, Olaitan Olutayo (2018) : Structural equation modelling of users' assessment of affordable housing in developing cities, Economic and Environmental Studies (E&ES), ISSN 2081-8319, Opole University, Faculty of Economics, Opole, Vol. 18, Iss. 3, pp. 1059-1087, <https://doi.org/10.25167/ees.2018.47.2>

This Version is available at:

<https://hdl.handle.net/10419/193130>

### Standard-Nutzungsbedingungen:

Die Dokumente auf EconStor dürfen zu eigenen wissenschaftlichen Zwecken und zum Privatgebrauch gespeichert und kopiert werden.

Sie dürfen die Dokumente nicht für öffentliche oder kommerzielle Zwecke vervielfältigen, öffentlich ausstellen, öffentlich zugänglich machen, vertreiben oder anderweitig nutzen.

Sofern die Verfasser die Dokumente unter Open-Content-Lizenzen (insbesondere CC-Lizenzen) zur Verfügung gestellt haben sollten, gelten abweichend von diesen Nutzungsbedingungen die in der dort genannten Lizenz gewährten Nutzungsrechte.

### Terms of use:

*Documents in EconStor may be saved and copied for your personal and scholarly purposes.*

*You are not to copy documents for public or commercial purposes, to exhibit the documents publicly, to make them publicly available on the internet, or to distribute or otherwise use the documents in public.*

*If the documents have been made available under an Open Content Licence (especially Creative Commons Licences), you may exercise further usage rights as specified in the indicated licence.*



# Structural equation modelling of users' assessment of affordable housing in developing cities

<sup>1</sup>Babatunde Femi AKINYODE, <sup>2</sup>Musibau Omoakin JELILI and <sup>3</sup>Olaitan Olutayo ODUNOLA

<sup>1,2,3</sup>Department of Urban and Regional Planning, Faculty of Environmental Sciences, Ladoke Akintola University of Technology, Postcode 210214, P.M.B.4000, Ogbomosho, Oyo state, Nigeria.

**Abstract:** This study investigated the users' assessment of affordable housing in developing cities among the residents of Ibadan urban centre. Affordable housing entails users having access to quality housing at reasonable prices, obtaining it, maintaining the ability to meet other basic costs of living and to stay in it without any problem in order to promote good health, accessibility, convenience and environment that is free from crime and violence. The study developed a theoretical model that links users' assessment to the affordable housing. Questionnaire was developed and administered to 494 residents in the five local government areas within Ibadan. The data was analysed using statistical packages SPSS and AMOS version 22. Exploratory factor analysis and confirmatory factor analysis techniques were applied to evaluate the users' assessment of affordable housing. The structural equation modelling as the validated measuring tools was employed to validate the theoretical model. The finding indicated that detailed examination, assessment and critical reflection of users on their affordable housing is an important step towards designing policies to improve affordable housing that is accessible to users. The authors are of the opinion that strategies through the employment of suitable housing policy are needed to address the challenge of existing affordable housing in developing cities.

**Keywords:** affordable housing, confirmatory factor analysis, exploratory factor analysis, structural equation modelling, users' assessment

**JEL codes:** R21, R22 and R31

**DOI:** <https://doi.org/10.25167/ees.2018.47.2>

## **1. Introduction and background of the study**

The rate of urbanisation is alarming in developing cities, resulting from mass migration from different parts of the countries. This consequently results in an increase in housing demand, inadequate and unaffordable housing provision to the majority of households (Akinyode, Khan, & Ahmad, 2015; Olayiwola, Adeleye, & Ogunshakin, 2005). Affordable housing entails users having access to quality housing at reasonable prices, obtaining it, maintaining the ability to meet other basic costs of living and to stay in it without any problem. Household's income and price of housing are parts of the significant factors that are being considered for housing that is affordable by the prospective users (Olatubara, 2007). However, the majority of housing users are low income households and inputs to housing production are too expensive. Thus, the provision of affordable housing remains a challenge to most cities in developing countries (Fisher, Pollakowski, & Zabel, 2009; Kutty, 2005). The economic situation of these low income households continues to place immense housing affordability challenge without taking into consideration good health, accessibility, convenience and environment that is free from crime and violence in the choice of affordable housing (Akinyode, 2016; Akinyode et al., 2015).

Governments all over the world have been concerned and involved in various housing programmes (Arimah, 1997; Fisher et al., 2009; Kutty, 2005). In Nigeria, the government's involvement in housing has lasted since the colonial era until today. Several policies and programs were embarked upon to ameliorate the problem of housing affordability. These included the establishment of Federal Mortgage Bank (FMBN), National Housing Policy (NHP 1991), National Housing Programme (NHP) between 1994 and 1995, establishment of Federal Ministry of Housing and Urban Development, Site and Services Scheme and the third National Housing Policy of 2002. None of these programs has significantly reduced the problem of housing affordability among Nigerians, especially amongst the low-income households. Lack of adequate funding on the part of the government to fund the programmes in housing and rehousing of the displaced people being affected by some of the policies resulted in ineffectiveness of these policies. Other problems associated with an insignificant impact of these policies included inadequate planning and conception, implementation weaknesses and accessibility problems to the National Housing Fund (NHF). The policies were implemented autocratically, without involving users. The socio-economic background of the users has not been given recognition in housing policies or programmes and a realistic way of solving housing

affordability problems for different users has not yet been developed. As a result, the majority of households, especially the low and middle-income households that were the main target of the policies were incapable of benefiting from the policies. Besides, the users' assessment of affordable housing has not been taken into consideration. Therefore, the policies turn out not satisfactory to the user. Thus, detailed examination, assessment and critical reflection of users on their affordable housing is of important in housing research that focuses on the users' affordability. This necessitates investigation of the users' assessment of affordable housing in developing cities as an important step towards designing policies to improve affordable housing that is accessible to them. This is with a view to developing a theoretical model that link users' assessment with the affordable housing.

It is on this basis that this study is embarked upon. This study therefore aimed at investigating the users' assessment of affordable housing in developing cities among the residents of Ibadan urban centre. Secondly, the study developed a theoretical model that links users' assessment with the affordable housing. It hypothesized that house rent, housing preference, housing satisfaction, land price and government intervention significantly influence users' assessment of affordable housing. This will help in bringing solutions to scale and preventing housing provision in the city that is only based on informal housing supply. This is mainly to develop a workable strategies through the employment of suitable housing policy for housing affordability for users in order to address the challenge of existing affordable housing in developing cities. This aims at bringing a relief to the users and promoting good health, accessibility, convenience and environment that is free from crime and violence.

The remaining part of this paper is structured in the following order: the second section of this paper is about the literature review that is centred on affordable housing, house rents, housing preference, housing satisfaction, and land price. This is followed by brief discussion about the study area and the methodology that briefly explains the variables, sample size, sample techniques, data analysis, interpretation and presentation method adopted in the study in sections three and four respectively. Section five of the paper presents and discusses the data, empirical results and findings. Lastly, the conclusions and policy implications of the paper are thereafter summarised in section six of the paper.

## **2. Literature Review**

### **2.1. Affordable housing**

Many researchers decided to describe affordable housing as housing costs without restrictions on non-housing consumption to the users (Crane & Warnes, 2000; Hulchanski, 2003; Moore & Skaburskis, 2004). Affordable housing elucidation should resonance the opportunity cost amongst housing and non-housing consumption. This criterion employs the ratio of house price to user's disposable income. Kutty (2005) and Stone (2006) explained affordable housing challenge as a situation when user cannot meet other needs like food, clothing, education, and medical services. Affordable housing challenge is a situation that results from squeezing incomes with housing costs. Kutty (2005) considered a user's living standard that cannot pay for non-housing goods to measure affordable housing problem. This is because many low income users are facing serious financial constraints of which they cannot afford to spend up to 25 to 30% of their revenue on housing without having problem in paying for other necessities. Rent burden or owner cost burden was also used to describe unaffordable housing (Fisher et al., 2009).

Stone asserted recognition of housing standards and household income sufficiency to cover housing and non-housing costs in order to measure affordable housing and uphold standard of living (M. E Stone, 1993; Michael E Stone, 2006). Bogdon and Can (1997) supported Stone's view and added that housing quality are what users acquire as dividend for whatever they expend on housing. Housing units within environment not accessible to jobs, quality facilities and infrastructures might experience low demand and abandonment to users of high income and educational status but only attractive to the aged or low-income users. Affordable housing problem especially among low and middle income households gave rise to slums and informal settlements within urban centres and periphery of the city as a result of poorly functioning housing markets (UN-Habitat, 2011). Such settlements are rarely healthy, comfortable and dignified places to live. This emerge in Australia and Canada when housing costs escalate over household incomes (Crane & Warnes, 2000; Moore & Skaburskis, 2004; Yates, 2008). Therefore, to increase housing users' quality of life, assessment of affordable housing should not be limited to economic viability but needs to consider some other factors. The problem of affordable housing resulted from extremely high price to income ratios is a major problems

preventing home ownership by individual households (Lau & Li, 2006; Wang & Li, 2006). Robinson, Scobie, and Hallinan (2006) considered how much of income placed on housing and how much of income left over for non-housing to measure financial stress. This study sees affordable housing as costs of owning or renting house without affecting the other aspects of users' wellbeing such as safety, comfort, convenience and living in an environment that is more conducive and free from crime and security. Besides, approximately 30% of the world's present population live in earthen structures (Binici, Aksogan, Bakbak, Kaplan, & Isik, 2009; Binici, Aksogan, Bodur, Akca, & Kapur, 2007). This is because it is cheap, environmentally friendly and abundantly available and used extensively for wall construction around the world to achieve affordable housing particularly in developing countries (Binici et al., 2007). Atterhög and Song (2009) discovered that it is often older and/or not so well maintained housing that is within an affordable price range for low-income households. According to them, a comprehensive housing condition survey in the UK from 1996 showed that the majority of the households are living in poor housing conditions. The outcome of Mulliner, Smallbone, and Maliene (2013) study revealed social and environmental as criteria that greatly affect affordable housing when compared with only financial attributes.

## **2.2. House Rents**

Various factors influence house rents within the housing market. The housing industry is composed of competitive firms and industry's aggregate supply depends on its output price and the real price of housing structure. Slight changes in housing demand or supply results to changes in house rents (Wheaton, 1990). House rents increase significantly with a greater change of household or market turnover. Therefore, there is positive correlation between house rents and housing demand. Increase in demand will lead to the increase in house rents. Limits to supply of any factor of production and increases in demand for construction also boost the equilibrium price of houses (Lee & Ong, 2005). This is in support of Meen (2002) who asserted that positive demand in housing leads to a temporary increase in housing prices on the short-run when there is inelastic housing supply, but prices overshoot on the long run because prices change in line with construction costs. Declining in the household consumption, employment and overall economic growth in New Zealand resulted to reduction in housing construction which at long run affected

the house rents to be increased (Snively, 2009) due to net migration flows that are generating more housing demand when the housing stock is already in short supply. House rent therefore represents the level of payment that is required of household to secure housing unit (Bramley, 2011).

### **2.3. Housing Preference**

Housing Preference is determined by housing condition and attributes assessed through housing unit itself in terms of its size and physical appearance; the house location in terms of its accessibility; social and physical characteristics of the neighbourhood environment as well as the services and facilities provided within the environment. The locational attributes of housing, such as distance and convenient access to their workplace (Tu & Goldfinch, 1996) and distance to public community amenities to access local amenities like schools, retailing outlets and public transportation stations (Clark, Deurloo, & Dieleman, 2006; Tan, 2012; Wang & Li, 2006) have been found to be an imperative factors that determine housing preference (Kauko, 2007). House rent fluctuations in housing market pose a greater risk to renters (Sinai & Souleles, 2003) which might push them to prefer neighbourhoods with lower rents and lower expected appreciation. Some scholars affirmed neighbourhood and locational indicators, such as environmental qualities of housing attributes as factors for housing preference (Tan, 2012; Yusuf & Resosudarmo, 2009; Zabel & Kiel, 2000). According to Tan (2012), households prefer and have the willingness to pay more for a house that is located in a good neighbourhood with good environmental qualities and in neighbourhoods with low crime rates and other security problems (Wang & Li, 2006). Anticipation of the improvement of a particular neighbourhood may be the determinant factors why household decides to move to another neighbourhood (Ellen, Horn, & O'Regan, 2013).

### **2.4. Housing Satisfaction**

Users' satisfaction on their resident is the degree to which users perceive their residential environment as able to meet their needs and attain their objectives (Yang, 2008). User's satisfaction on housing and general appearance of the neighbourhood were closely associated with user's satisfaction (Parkes, Kearns, & Atkinson, 2002). There may be greater concentrations

of satisfaction of users with particular neighbourhoods while they may not be satisfied with deprived neighbourhoods. Different factors may be responsible for users' satisfaction or dissatisfaction with a particular neighbourhood. These factors may include environmental factors, such as physical appearance, noise, crime, social disorder and availability of facilities provided, as well as the quality of life of the other residents within the neighbourhood. Yang (2008) discovered that outmoded housing, insufficient public facilities and amenities, high populations of households of lower socio-economic status are directly related to the residential physical appearance that affects users' residential satisfaction.

## **2.5. Land Price**

Government policy in restricting urban boundaries may cause the aggregate housing supply curve to shift inward (Dawkins & Nelson, 2002). The urban restraint boundaries will reduce the number of landowners supplied with parcels of land, thereby resulting in affordable housing production being concentrated in the hands of only a few landowners possessing developable land. When there is an increase in the demand for housing, a decline in developable land may lessen the number of new housing units thereby escalating the price of new housing. However, Dawkins and Nelson (2002), in their study, asserted that the demand side of the housing market is a stronger determinant of prices than government urban restricting policies and concluded that local planners can play a substantial role in relation to the severity of housing price inflation associated with urban restricting policies.

The cost of land, bureaucratic challenges related to land acquisition and a high interest rate constituted problems to affordable supply of rental housing (Arku, Luginaah, & Mkandawire, 2012; Gough & Yankson, 2011). The housing shortage due to high land price in Ghana has resulted in houses constructed by private developers being very expensive and mainly for profit making. Consequently, the expensive private sector's housing price, cost of land, bureaucratic challenges related to land acquisition and high interest rate have brought about affordable housing problems.



### **3. The study area**

Ibadan the capital city of Oyo state had a population of 1,353,816 according to National Population Commission (2010). The city is located in south-western Nigeria approximately on longitude 3051 East of the Greenwich Meridian and latitude 70231 North of the Equator at a distance of about 145 kilometres inland northeast of Lagos and 530 kilometres southwest of Abuja, the federal capital territory (FCT). Ibadan ranges in elevation from 150 metres in the valley area to 275 metres above sea level on the major north-south ridge that crosses its central part. The total land area is 3,080 square kilometres. Ibadan served as administrative centre for the old Western Region since the period of British colonial rule and as a camp by the soldiers of the Ife, Ijebu and Oyo after they had successfully destroyed the neighbouring kingdom of Owu. The British established the new colony to ease their commercial activities in the area which eventually led Ibadan to be developed as a major commercial centre that it is today. The physical setting of the city consists of ridges of hills that mostly lies in the central parts such as Mapo, Mokola and Aremo.

### **4. Methodology**

According to 2006 household population census (NPC, 2010), the total household population for the five local government areas is 350,668 households. There are total number of 80,048 households in Ibadan North, 84,060 households in Ibadan North-East, 40,459 households in Ibadan North-West, 70,449 households in Ibadan South-East and 75,652 households in Ibadan South-West which is 22.83%, 23.97%, 11.54%, 20.09% and 21.57% respectively. Extensive quantitative research method was adopted in this study with the employment of questionnaire administration among five hundred (500) participants representing a sample frame 0.14% of the entire 350,668 households through stratified random sampling for data collection. The questionnaire was developed on the basis of variables found in the literature and consisted of two sections. Section A included a socio-economic/household survey and attributes of current affordable houses. It consisted of 34 questions. The socio-economic/household survey dealt with questions on sex, age, marital status, employment status, income of the respondents and the like. The attributes of current affordable houses focused on housing tenure, tangible attributes and intangible attributes. Section B focused on questions related to house rents, housing preference,

housing satisfaction, land price, government intervention and affordable housing and consisted of 29 questions. Section A was designed in multiple-choice closed-ended questions with options. Section B was designed in 5-point Likert scale format ranging from strongly disagree which was given 1 point to strongly agree which was given 5 points. This was to measure users' assessment of the affordable housing. The respondents were requested to choose between strongly disagree and strongly agree.

Among the 500 participants, 113 respondents were selected in Ibadan North local government area, 119 respondents in North-East local government area, 59 respondents in North-West local government area, 101 respondents in South-East local government area and 108 respondents in South-West local government area representing 22.60%, 23.80%, 11.80%, 20.20% and 21.60% of the sample frame respectively. The ratio for each of the local government areas depended upon the number of households in each of them. After distributing the appropriate number of questionnaires to different local government area, each of them thereafter was subdivided into wards. The number of the questionnaires that was administered in each ward depended upon the number of the political counting unit in each of them. In selecting the particular households to be interviewed in each of the political counting unit area within the ward, a simple random sampling method was adopted after the number of questionnaires have been allotted to each of the political wards. It was assumed that every household within the counting unit area has an equal chance of being interviewed. The sampling concept assumed every respondent to be the head or representative of a household.

Through verification of the questionnaires, six questionnaires were incomplete and then discarded. The remaining 494 questionnaires representing 494 respondents equivalent to a response rate of 98.80% were found useful for the analysis in this study. This implies that the study suffers from a nonresponse bias of 01.20%. The number of completed questionnaires is considered to be adequate enough for analysis in line with the recommendation of Jack (2008). The reason for the very high response rate primarily resulted from the direct contact of the enumerators and researcher with the potential respondents. Determination of the general trends in the data was made through a descriptive analysis, such as means, frequency, and standard deviation (SD) as well as variance of responses on each item variables. The quality of the scores from the data collection instrument was also examined through reliability and validity tests (Creswell & Clark, 2011). Cronbach's alpha was used to assess the internal consistent reliability

of the survey instrument. The Alpha value of 0.741 for all the 29-item variables in section B was considered sufficiently reliable and acceptable indicating strong reliability of the measurement. The value of the Cronbach's alpha above 0.70 is considered to be an acceptable level (Newton & Meyer, 2010; Shanmugapriya & Subramanian, 2013; Wong & Cheung, 2005) and sufficiently reliable for an exploratory study such as this. George and Mallery (2003) also considered Cronbach's alpha value of 0.7 to be an acceptable one. The study also recorded higher respondents of 494 administered questionnaires with KMO value of 0.852, which signified reliable, adequate and valid survey sampling (Field, 2009).

The data was analysed statistically using statistical program for the social sciences (SPSS) and structural equation modelling (SEM) tool with the aid of AMOS (Analysis of Moment Structures) software version 22. The SPSS and AMOS packages were used because of their effectiveness in reducing data and testing the models in behavioural and social sciences research to achieve the objective of the study. The initial processes of model development and presentation of the result was made through the use of exploratory factor analysis (EFA) and confirmatory factor analysis (CFA). EFA was aimed at identifying questionnaire items that best defined each variable scale, removing those items that did not contribute to a particular variable scale and correlate the items that have the same direction towards contributing to a particular variable scale. Though, a scholar suggested factor loadings of .30 and above to be considered significant for the analysis in EFA (Joe, 1991). However, in this study, by researcher's judgement, only factor loadings of .50 and above were considered significant, as a chosen factor loading of less than .50 would lead to an unclear pattern of the factors.

CFA was aimed at validating and confirming the variables that measured the factors in order to evaluate the factor structures within a measurement model. This was to ascertain how well the measurement model fits the data (Bollen, 1989). Various measures were used to assess the fitness of the model to the data. The measures included assessment of normality, regression weight, standardized regression weights and square multiple correlation ( $R^2$ ) as well as variance, residual covariance, correlations, covariance and outliers. Though, Chi-square ( $X^2$ ) of estimated model is almost always statistically significant for large sample sizes. Therefore, the measure of model fit cannot be limited to its use. The use of other multiple measures of model fit was then suggested (Hoyle, 2012; Tanguma, 2001). These included Ratio, Adjusted Goodness of Fit Index (AGFI), Goodness of Fit Index (GFI), Comparative Fit index (CFI), Parsimonious Comparative

Fit index (PCFI), Normed Fit Index (NFI), The Root Mean Square Error of Approximation (RMSEA) and Akaike Information Criterion (AIC) were also used to assess the fitness of the model. The path analysis measured the level of contribution of each factors to the affordable housing in the structural equation modelling (SEM).

The assessment of normality indicating greater values of skewness ranging from -1 to +1 and kurtosis ranging from -1.5 to +1.5 for some variables which, based on the suggestion of some researchers, were identified as the most problematic in the model. The regression weight of the variables should be significant at p value of .05, the standardized regression weights estimates of variables to be greater than 0.5 and Squared Multiple Correlations estimate of variables to be more than .1. Furthermore, ratio should be equal or less than 5.0 (Bagozzi & Yi, 1988; Hair, Black, Babin, & Anderson, 2010). 0.80 is the acceptable value for GFI, AGFI and CFI (Chau & Hu, 2001; Hair et al., 2010). RMSEA should not be more than maximum recommended level of 0.09 (Browne & Cudeck, 1993) or 0.10 (Hair et al., 2010). Tanguma (2001) saw CFI as one of the most stable of fit indices, least impacted by sample size. The higher the value of PCFI, the better, while the lesser the value of AIC, the better. In the structural equation modelling, this study considered the path loadings of 0.1 and above as significant loading as recommended by other scholars (Cohen, 2013; Manafi & Subramaniam, 2015). The outcome of the analysis was illustrated diagrammatically with standardised estimates in first and second order factors format. The unstandardized estimates was not presented because of the space.

#### **4.1. The theoretical underpinnings of the study**

For this study, SEM as the validated measuring tools was employed to develop and validate a theoretical model that links users' assessment with the affordable housing. The theoretical model of assessing the relationship between endogenous latent variable affordable housing with five variables and its indicators combined in five factors represented as exogenous latent variables in the data input from AMOS software are shown in Figure 1. The rectangle represents the manifest variable, while the oval shaped represents the list of endogenous latent variables.

**Figure 1. Theoretical model of users' assessment of affordable housing and its indicators**

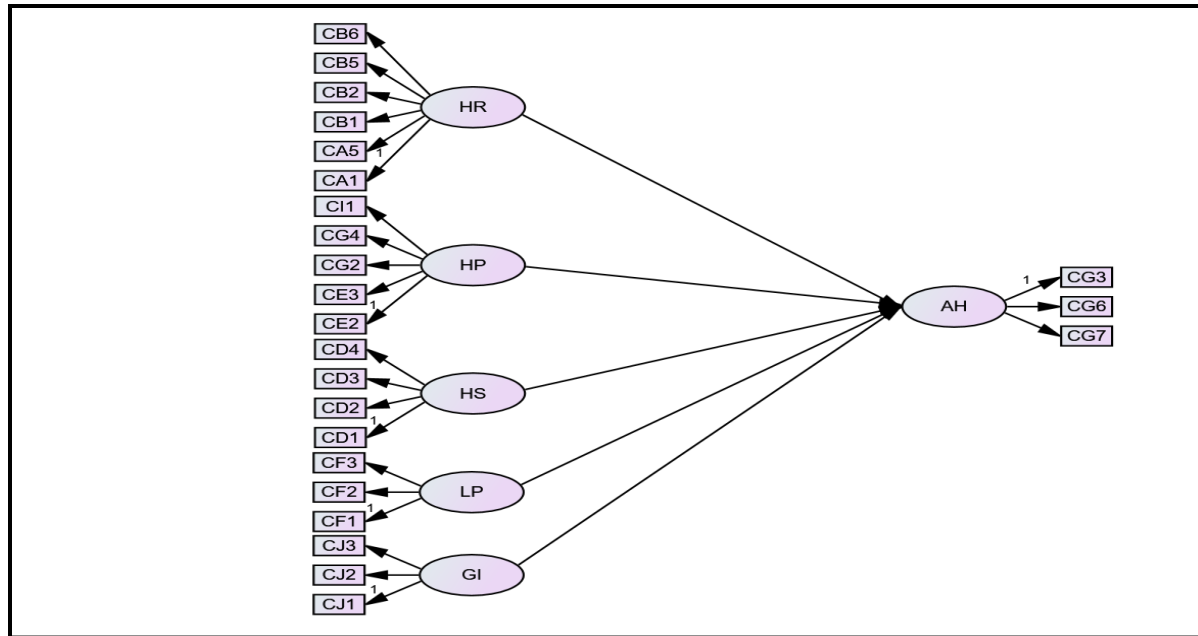

Source: Author's own design, 2018

Where CA1 = High house rent, CA5 = House rent not satisfying, CB1 = Short housing supply, CB2 = Income increase, CB5 = General inflation, CB6 = Landlord's decision, CD1 = House environment, CD2 = House security, CD3 = Lack of facilities, CD4 = Place of work distance, CE2 = Good physical condition, CE3 = House well maintained, CF1 = Expensive land area, CF2 = High demand on land, CF3 = Increase in population, CG2 = Area is suitable, CG3 = House price factor, CG4 = People level of education, CG6 = House price increase effects, CG7 = House construction price increase, C11 = High income earners, CJ1 = Government's intervention on the rate of housing supply, CJ2 = Government's intervention on housing typology and CJ3 = Government's intervention on housing supplier's decision.

## **4.2. Modification**

To estimate the measurement model with the latent variables, modifications are made to the model. There are three approaches in modifying a model like this. Firstly, modification can be in the form of elimination of those items that did not contribute to a particular variable scale, has low theoretical importance or a low communality (Bian, 2011). Secondly, correlation among items that have the same direction towards contributing to a particular variable scale because some common unmeasured latent variable is influencing both of them (Schumacker & Lomax, 2004, 2010). The third approach is the combination of the first two approaches (Arbuckle, 2013; Huang, 2011; Loehlin, 2004) to improve model fitness to data. However, any modification to be adopted must be justified on theoretical grounds (Arbuckle, 2013; Loehlin, 2004) to enhance genuine improvement in measurement or theory. This study adopted the third approach which is the combination of elimination of those items that did not contribute to a particular variable scale and correlation among items that have the same direction towards contributing to a particular variable scale. Consideration was given to the modifications that make sense and are theoretically based.

## **5. Results and Discussions**

### **5.1. Exploratory Factor Analysis (EFA)**

EFA technique was applied to sort out the significant factors of affordable housing. Barlett's test of sphericity and KMO of sampling adequacy were run to determine the suitability of data and adequacy of the sampling. These two parameters justified the application of the EFA that led to the employment of principal component analysis technique. Using latent root criterion, five factors were extracted (with eigenvalues greater than 1) with 64.28% of variance. EFA was performed on 29-item variables to examine their loadings. The item attributes that manifested equal or greater than 0.50 coefficient in the factor constructs were considered significant for the analysis. In achieving this, the questionnaire item variables with factor loading less than 0.50 were eliminated from the item set. The remaining 21 items were then grouped into five factors

assessed by the users as the factors that affect affordable housing. The 6th factor with three-item variables are to measure affordable housing (AH) which was identified and hypothesised to be a variable dependent on the other five latent variables. House Rents (HR with six-item variables), Housing Preference (HP with five-item variables), Housing Satisfaction (HS with four-item variables), Land Price (LP with three-item variables) and Government Intervention (GI with three-item variables) are the five factors assessed by the users to determine affordable housing with the total number of 21-item variables as shown in Table 1. The varimax orthogonal rotation of principal component analysis was used in this study to group the factors.

**Table 1. Exploratory Factor analysis (EFA) loading results**

VARIABLES	Rescaled Component					
	A	B	C	D	E	F
<b>House Rents (HR) – FACTOR A</b>						
My house rent is high because of arbitrary increase by landlords	.827					
My house rent is high	.762					
My house rent is high because housing is in short supply in Ibadan	.742					
The percentage of income expended on my house rent is more than 30%	.726					
My house rent is high because of general inflation	.726					
I am not satisfy with the house because of High Rent	.641					
<b>Housing Preference (HP) – FACTOR B</b>						
The physical condition of my house is good		.734				
I can rate/evaluate my house to be well maintained		.721				
My house rent is high because this area is high income earners area		.652				
The level of people’s education in this area is high		.623				
The condition of this area is suitable for living		.567				
<b>Housing Satisfaction (HS) – FACTOR C</b>						
I am not satisfy with the house because of Lack of facilities			.743			
I am not satisfy with my house because of Environment			.742			
I am not satisfy with the house because of Security			.691			
I am not satisfy with the house because of Distance to the place of work			.520			
<b>Land Price (LP) – FACTOR D</b>						
The land price in this area is expensive because of high demand on land				.627		
The land price in this area is expensive because of increase in population				.596		
The land price in this area is expensive				.591		
<b>Government Intervention (GI) – FACTOR E</b>						
Planning policies have impacts on the typology of housing built					.877	
Planning policy affects the rate of housing supply					.860	
Planning policies have impact on housing supply					.677	
<b>Affordable Housing (AH) – DEPENDENT FACTOR</b>						
Construction Price increase affects the owners to degrade quality						.749
House Price affects the choice of houses						.658
House Price is a big factor in affordable houses						.610

Source: Extraction Method: Principal Component Analysis; Rotation Method: Varimax with Kaiser Normalization.a; Rotation converged in 5 iterations; a: loading less than 0.49

## 5.2. Confirmatory Factor Analysis (CFA)

CFA was performed to establish the relationship and strength of the factors within the measurement model in order to validate and confirm the variables that measure the factors. This is to evaluate the factor structures within a measurement model in order to ascertain how well the measurement model fits the data. The variables in users' assessment were converged as unobserved latent factors to measure each factor according to the EFA result. Each of the factors in users' assessment has a minimum of three indicators for identification and fulfilled the suggestion of Kline (2011). Modifications to the measurement models were made to get the model fitted well to the data in terms of elimination of those items that did not contribute to a particular variable scale, has low theoretical importance or a low communality (Bian, 2011). The correlation was also made among items that have the same direction towards contributing to a particular variable scale because some common unmeasured latent variable is influencing both of them (Arbuckle, 2013; Choi, 2004; Huang, 2011; Loehlin, 2004; Schumacker & Lomax, 2004, 2010). A discriminant analysis of the users' assessment was carried out in order to ensure all variables that are capable of measuring the construct. Discriminant validity is assessed to determine the extent to which independent measured variables are correlated. This is obtained through varieties of investigation that necessitates unobserved constructs to be correlated to each other. The result of the discriminant validity is shown in Figure 2 with Chi-square = 712.117,  $df = 179$   $p < .001$ , Ratio = 3.978, AGFI = .829, GFI = .867, CFI = .873, PCFI = .744, NFI = .838, RMSEA = .078, and AIC = 816.117.



**Figure 2. Discriminant validity of users' assessment**

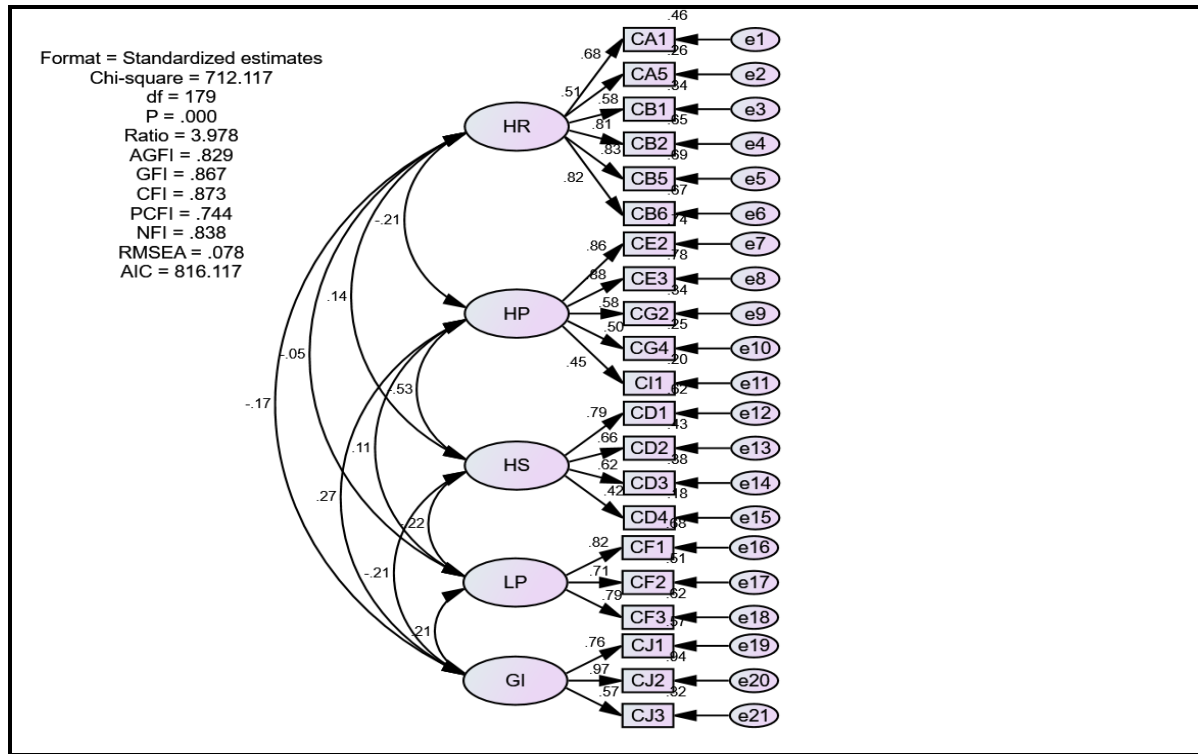

Source: Author's field work, 2017.

There is a difference between the values of unconstraint and constraint conditions. The Chi-Square statistic of the unconstrained model is smaller than the constrained model at 1 degree of freedom. This implies that the variables within the construct are discriminate to each other. That is, each variable that converged to construct was statistically proven not to be a measure of other construct. Factors (LP and GI) with the unconstrained Chi-Square 0.000 and the degree of freedom (df) 0 are the factors with only three variables that AMOS version 22 was unable to estimate the measurement model. This suggests that the number of the distinct sample moments was equal to the number of the distinct parameters to be estimated. Investigation into the assessment of normality is very crucial at this stage. The values of skewness and kurtosis might guide in the elimination of a particular variables that might be problematic in the construct. Examination of the assessment of normality is made to reveal the values of skewness and kurtosis in order to guide in the elimination of a particular variables that might be problematic in the construct.

The majority of researchers suggested the skewness values ranging from -1 to +1 to identify the most problematic variables in the whole model while the kurtosis values can be up to

-1.5 to +1.5. On the basis of this suggestion, skewness value of the variable that exceeded between -1 and +1 was identified as the most problematic variable in this study. The kurtosis value of the variable that exceeded between -1.5 and +1.5 was also identified as the most problematic variable. As a result of the modifications made to the measurement models to achieve a better model fit, there was improvement in the model fitness. The results of the modification are shown in Figure 3 with Chi-square = 270.390,  $df = 95$ ,  $p < .001$ , Ratio = 2.846, AGFI = .907, GFI = .935, CFI = .945, PCFI = .748, NFI = .918, RMSEA = .061, and AIC = 352,390. At this stage, there is improvement in the model fitness. The measurement model shows that all the quantitative variables in standardized and unstandardized estimates indicate that the model fits well to the empirical data and the CFA, using path analysis, indicated that the factor complies with the acceptable limit of goodness of fit.

Investigation of squared multiple correlations shows that the majority of variables has more than 0.5 estimate and there is no variable with less than 0.1 estimate. The majority of standardized regression weights are more than .5 estimates. This implies that all the variables are good measures of the identified factor. In a sufficient large sample size, the standardized residual covariances have a standard normal distribution if the model is correct. Most of the standardized residual covariances should be less than 2.0 in absolute value to indicate the standard normal distribution (Jöreskog & Sörbom, 1996) and confirm that the model is correct. Investigation of standardized residual covariance analysis shows that all the sample covariance between variables less than 2.0 in absolute value indicate the standard normal distribution and confirm that the model is correct. It can therefore be established that there is no problem with model design.

**Figure 3. The modified discriminant validity of users' assessment**

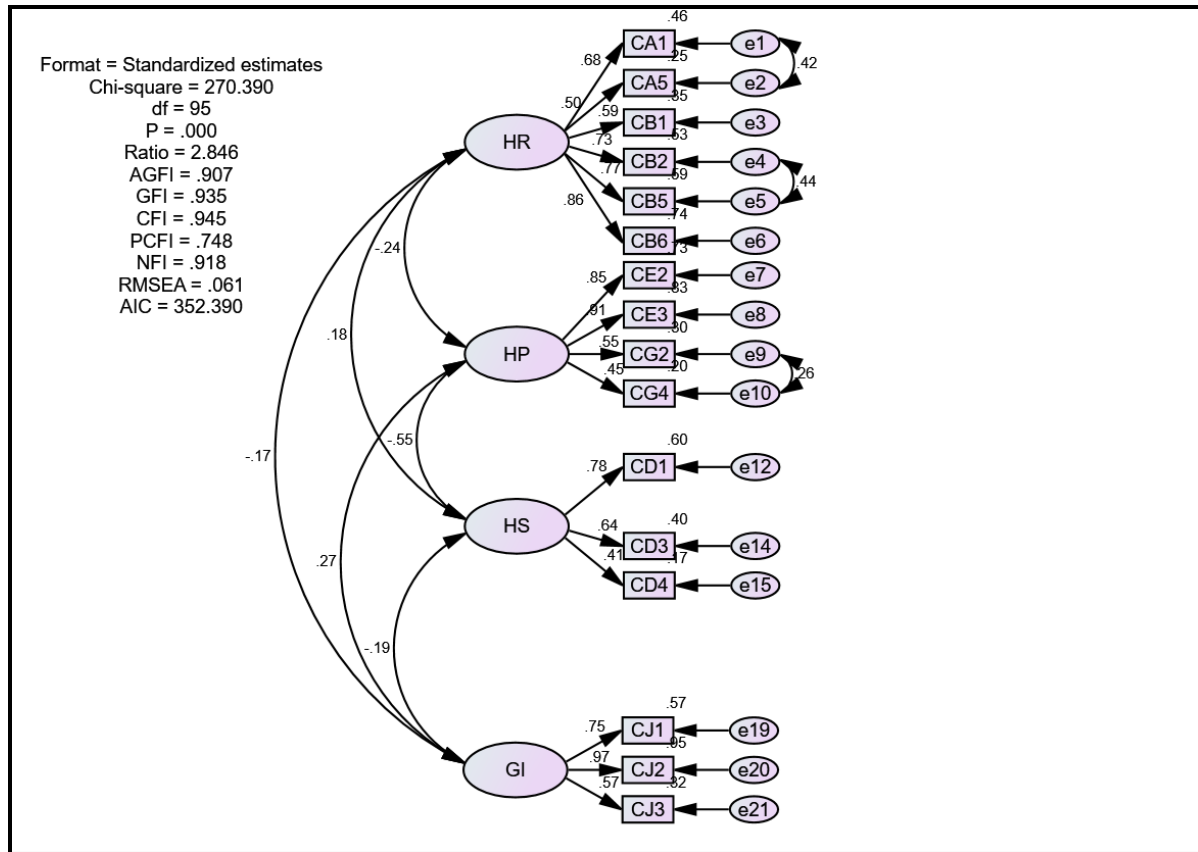

Source: Author's field work, 2017.

Assessment of the normality also indicates no value of skewness and kurtosis exceeded 1 in absolute value, indicating that the empirical data is normally distributed. The regression weights estimate shows that all the factors are significant in measuring the construct of users' assessment. The covariances between the factors are significant at p value .05 and there is no negative variance. Based on these results, the measurement model and its variables are acceptable and are good to measure users' assessment. The factors that are finally considered to measure users' assessment are four namely: HR (House rents), HP (Housing preference), HS (Housing Satisfaction) and GI (Government intervention). Generally, CFA was performed to establish the relationship and strength of the variables in measuring the factors within the measurement model. The technique was applied to establish the relationship among the users' assessment within a measurement model in order to ascertain how well the measurement model fits the data. The EFA established five factors within the users' assessment. The five factors were

considered in the analysis but only four factors with 16 variables were confirmed through the CFA to measure users' assessment as shown in Table 2.

**Table 2. Confirmed variables by CFA according to each factor**

F/ID	Factor	V/N	Variables
A	House rents	1	High House Rents
		2	House Rents not Satisfied
		3	Short Housing Supply
		4	Income Increase
		5	General Inflation
		6	Landlords' decision
B	Housing preference	7	Good condition
		8	Well Maintained
		9	Suitable Area
		10	People's education
C	Housing satisfaction	11	House Environment
		12	Lack of Facilities
		13	Work Distance
E	Government intervention	14	On Housing Supply Rate
		15	On Housing Typology
		16	On Housing Supplier Decision

Source: Author's field work, 2017.

The CFA confirmed six variables to represent the House rents (HR), four variables to represent the Housing preference (HP), three variables to represent the Housing satisfaction factors (HS) and three variables to represent the Government intervention (GI). It can therefore be inferred that sixteen variables are confirmed through the CFA to measure the users' assessment. In summary, the process of modification during the CFA eliminated a total number of five variables out of 21 variables. The CFA eliminated factor LP with three variables, one variable from factor HP and another variable from factor HS totalled five variables out of five factors comprises of 21 variables that were designed to measure users' assessment according to the EFA. As a result of the elimination of one factor and additional two variables, four factors comprised of 16-item variables were retained and each of the factors consists of a minimum of three variables in the CFA, as recommended by Anderson and Gerbing (1992). The measurement of model variables, analysed with the CFA result, shows that the model fit the data. All factor loadings exceeded 0.5 at the significance level of  $p < .001$ , according to standardized regression weights estimates.

The unstandardized and standardized estimates in Figure 3 of the confirmatory analysis result revealed that chi-square for the measuring model was Chi-square = 270.390,  $df = 95$ ;  $p < .001$ , Ratio = 2.846 which is less than 5.0 and it is a good value as recommended by Bagozzi and Yi (1988) and Hair et al. (2010). The adjusted goodness of fit index (AGFI) was 0.907; goodness of fit index (GFI) was 0.935; Comparative Fit index (CFI) was 0.945; Normal Fit Index (NFI) = 0.918. All these exceeded the recommended marginal acceptable value of 0.80 (Chau & Hu, 2001; Hair et al., 2010). The Parsimony Comparative Fit Index (PCFI) = 0.748 is also within the specification, the lower the value, the better (Chau & Hu, 2001; Hair et al., 2010). The root mean square error of approximation (RMSEA) was 0.061, which was below the maximum recommended level of 0.09 (Browne & Cudeck, 1993) and of 0.10 (Hair et al., 2010). The output result of the CFA shows that the measurement model exhibited a good degree of acceptability and it provides support for the relationship among the users' assessment at the significance level of 0.05.

### **5.3. Structural equation modelling (SEM) of users' assessment of affordable housing**

The researcher had hypothesized that house rents, housing preference, housing satisfaction, land price and government intervention significantly influence users' assessment of affordable housing. Better exposition of the mechanisms through which this ensues is essential. The structural equation modelling (SEM), as the validated measuring tools, was applied to develop and validate the confirmatory theoretical model. This is to test the hypothesis in demonstrating the influence and degree of users' assessment of confirmed factors on affordable housing. This entails statistical approaches, such as path analysis, regression and square multiple correlation ( $R^2$ ) to determine the influence and degree of the users' assessment of variables on affordable housing. A sequence of procedure was strictly followed in order to achieve this through the SEM. Four factors were considered according to CFA and these include:

- i. House rents (HR) represented by six manifest variables,
- ii. Housing preference (HP) represented by four manifest variables,
- iii. Housing satisfaction (HS) represented by three manifest variables, and
- iv. Government intervention (GI) represented by three manifest variables.

The theoretical structural equation model of assessing the effects of exogenous latent

variables users' assessment on endogenous latent variable affordable housing, as shown in Figure 4, was tested. The rectangle represents the manifest variable, while the oval-shaped represents the list of endogenous latent variables. This suggests that the sixteen-item variables from the four users' assessment, measured by house rents, housing preference, housing satisfaction and government intervention, influence affordable housing through which the SEM was tested.

**Figure 4. Theoretical initial structural equation model to illustrate the users' assessment with their indicators on affordable housing (AH)**

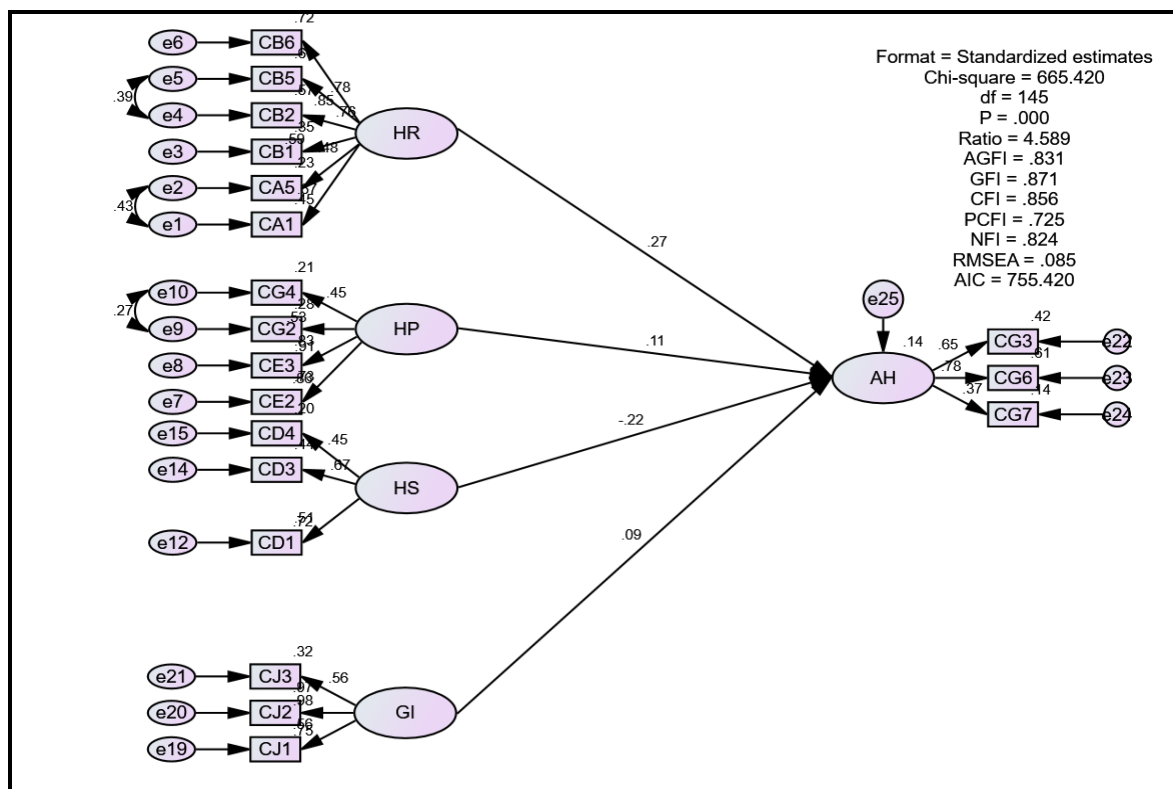

Source: Author's field work, 2017.

Schumacker and Lomax (2010) explained latent variables (constructs or factors) as the variables that are not directly observable or measured but indirectly observed or measured, while the observed, measured or indicator variables are the set of variables that are used to define or infer the latent variable or construct. Latent variables in SEM generally correspond to hypothetical constructs or factors, which are explanatory variables presumed to reflect a continuum that is not directly observable but an observed or manifest variables used as indirect

measure of a construct referred to as indicators (Kline, 2011). The initial structural model was tested using the sampled data with the aid of AMOS version 22 software. At a start, the measurement model was tested without correlation among the factors, as shown in Figure 4 and later tested with the factors being correlated, as shown in Figure 5. This is in accordance with the suggestion of Anderson and Gerbing (1992) and Kline (2013). To determine the good model fit at this stage, model fit indices were limited to the commonly accepted model indices and these include Ratio which should be equal or less than 5.0 as recommended by Bagozzi and Yi (1988) and Hair et al. (2010). A marginal acceptable value of 0.80 was recommended for the goodness of fit index-GFI, adjusted goodness of fit index-AGFI, Comparative Fit index-CFI (Chau & Hu, 2001; Hair et al., 2010). The root mean square error of approximation (RMSEA) should not be more than maximum recommended level of 0.09 (Browne & Cudeck, 1993) or of 0.10 (Hair et al., 2010).

**Figure 5. The final structural equation model to illustrate the users’ assessment of affordable housing**

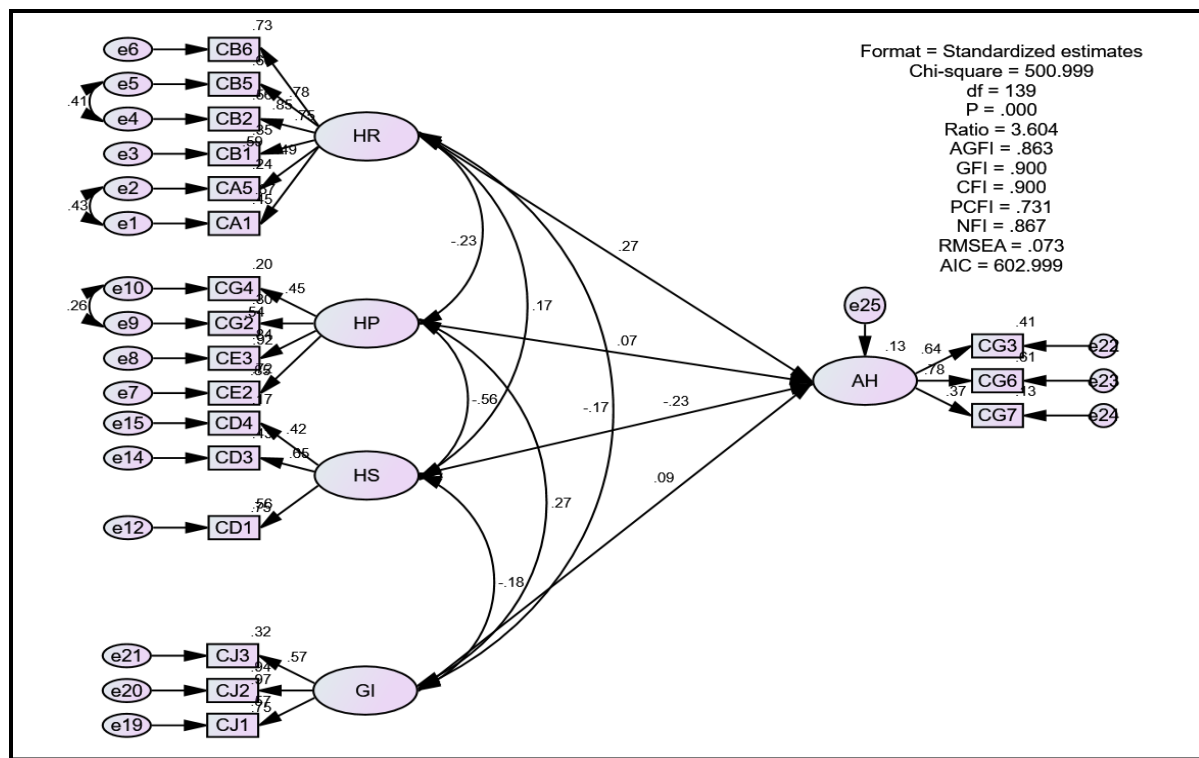

Source: Author’s field work, 2017.

The initial SEM tested without correlation among the factors, as shown in Figure 4, indicates  $p < .001$ , Ratio = 4.589, AGFI = 0.831, GFI = 0.871, CFI = 0.856 and RMSEA = 0.085. With this result, all the indicators fit well to the corresponding data of 494 respondents and the model can be accepted. However, the initial structural equation model was adjusted and modified by correlating the factors, as shown in Figure 5, in order to confirm if a better and acceptable model fit can be achieved. The correlation among the factors was made on the initial model. The model confirmed a better and acceptable model fit with  $p < .001$ , Ratio = 3.604, AGFI = 0.863, GFI = 0.900, CFI = 0.900 and RMSEA = 0.073. Various indicators, such as assessment of normality, standardized regression weights, variance, correlations, covariance, squared multiple correlations ( $R^2$ ) and outliers were further considered for investigation to be sure that no variable is problematic in the model. This implies that the variables display slight univariate normal distribution. The standardized regression weights shows that the majority of variables are above 0.7 estimate, which infers that they are capable of measuring the construct within the model. The majority of variables also exhibit more than 0.5 squared multiple correlations estimate which exceeded 0.1 recommended by Sarros, Gray, Densten, and Cooper (2005).

Nevertheless, standardized regression weights indicate low estimate of the users' assessment of affordable housing. The standardized regression weights of users' assessment HP, HS, GI and HR on affordable housing specifies 0.073, -0.225, 0.087 and 0.275 and the path analysis estimate shows 0.07, -0.23, 0.09 and 0.27, respectively. Although the standardized regression weights stipulate low estimate of the users' assessment of affordable housing, the path analysis estimate between the users' assessment and affordable housing exhibits a strong influence. This implies that the users' assessment has a significant influence on affordable housing. Moreover, the value of variance cannot be negative, as it means the model is wrong (Jöreskog & Sörbom, 1996). The examination of variances analysis indicates no negative variance within the construct. The implication of this is that all the variables can measure the factors within the model and users' assessment significantly influence affordable housing.

According to the path analysis, house rent and housing satisfaction contribute more to the affordable housing than the other two factors (housing preference and government intervention). Users are not satisfied with the house they are living in, in addition to the fact that the rent is too expensive for them to bear. The house environment, lack of facility and distance to the place of work are the contributing factors why the users are not satisfied with the affordable housing.



However, they continue living in the house as a result of the fact that they could not get a better place to reside because of their financial capability. This result supports the assertion of Davenport (2003) and Chen, Tsai, and Chang (2007) who claimed that a household's income is the significant factor that influences affordable housing demand. The environment is not conducive to living and exhibits a lack of facilities. The majority of users are living within the slum area of the city. The landlord's decision on the rent by reason of shortage of housing supply has a great impact on the purposes why the house rents are high. This is in line with the discovery of McQuinn and O'Reilly (2008) who opined that a house rent is a function of housing demand and supply. The arbitrary increase in a house rent by landlord affects the affordable housing the users reside. The majority of users cannot afford a decent house for living, but in a horrible unhealthy built-up locations (Mukiibi, 2012; Onibokun, 1985; Otubu, 2009). Government is not helping the situation. All the efforts of the government in making the housing affordable for users, especially the low income households are not effective. Relating this result to the researcher's observation confirms that instead of planning and government policy to enhance affordable housing, it only enforced the users to locate their house in a rural area. On account of this act, the newly developing areas are turning into slum areas because of lack of proper planning.

This study considered the path loadings of 0.1 and above as a significant loading in accordance with the recommendation of other scholars (Cohen, 2013; Manafi & Subramaniam, 2015). Based on this, the results indicate that house rents (HR) and housing satisfaction (HS) are practically significant to affordable housing exhibiting path loadings of 0.27 and 0.23, respectively. The housing preference (HP) and government intervention (GI) have little influence, together with path loading of 0.07 and 0.09, respectively, on affordable housing. This denotes that their influence on affordable housing is not practically significant, according to the recommendation of Manafi and Subramaniam (2015) and Cohen (2013), as shown in Table 3. Generally, the result submits that users' assessment significantly impacts on the affordable housing. In summary, the examination of users' assessment of affordable housing rated by the respondents were measured using four factors with numbers of item variables.

**Table 3. Summary of the Structural Equation Model Results**

Influence of the Path	Path Loadings	Results
House rents (HR)	0.27	Supported
Housing preference (HP)	0.07	Not Supported
Housing satisfaction (HS)	-0.23	Supported
Government intervention (GI)	0.09	Not Supported

Source: Author's field work, 2017.

This is in accordance with the EFA and CFA. The four independent factors used to determine the users' assessment of affordable housing are the confirmed factors for users' assessment. The significance of the model was determined with AMOS as a reliable tool in SEM to test the causal relationships that have multiple indicators (Jöreskog & Sörbom, 1996). The CFA was used to test the entire measurement model of the relationship between the users' assessment and affordable housing (Anderson & Gerbing, 1992). The factor loadings for all the indicators were significant at 0.05 level indicating good loadings as stipulated by Bagozzi and Yi (1988).

## 6. Conclusions and policy implication

Accessibility to affordable housing provision is related to households' standard of living, improvement in housing stock and when it is well planned, with an acceptable standard of infrastructure and affordable cost, it becomes strategically important for social and economic investment. The majority of respondents are relatively of low income and do not like their present housing condition. Major impediments to affordable housing include a lack of sufficient affordable housing supply and low income of the majority of users. Differences among residents in cities and their income should be considered in housing policy formulation. Every household should have access to affordable housing. The housing policy makers need to be conscious of the fact that the majority of users within cities are confined to insufficiency. The policy should therefore impose individual privileges and produce openings for every personality in accomplishing their full potential. In view of this, ameliorating affordable housing predicaments among different users in Ibadan should be given urgent attention. Housing contributes towards improved users' health and increases their productivity. The government should see affordable housing as a situation whereby every individual or household lives in a decent housing

environment with safety, comfort and convenience as well as security, health and privacy. The research findings are not only applicable to Ibadan urban centre but can be replicated in other urban centres in Nigeria as well as other developing countries.

The future investigation can therefore be made on critical factors that affect users' assessment for affordable housing. This can therefore be considered as a limitation to this study. This study can also be replicated in some other urban centres within Nigeria to test the applicability and generality of the findings. This is to provide an avenue to address some other variables such as culture, demand and supply factors that affect the choice of location and house type which cannot be addressed in the analyses of this study.

## Literature

- Akinyode, B. F. (2016). Effects of Urbanisation on Urban Housing among Low Income Households in Nigeria. *British Journal of Humanities and Social Sciences*, 14(1), 10-22.
- Akinyode, B. F., Khan, T. H., & Ahmad, A. S. B. H. (2015). Socio-Economic Factors in Measuring the Demand for Residential Neighbourhood in Nigeria. *Asian Social Science*, 11(12), 235-247. doi:10.5539/ass.v11n12p235
- Anderson, J. C., & Gerbing, D. W. (1992). Assumptions and Comparative Strengths of the Two-Step Approach-Comment on Fornell and Yi. *Sociological Methods & Research*, 20(3), 321-333.
- Arbuckle, J. L. (2013). *Amos 22 User Guide*: Amos Development Corporation.
- Arimah, B. C. (1997). The Determinants of Housing Tenure Choice in Ibadan, Nigeria. *Urban Studies*, 34(1), 105-124. doi:10.1080/0042098976294
- Arku, G., Luginaah, I., & Mkandawire, P. (2012). "You Either Pay More Advance Rent or You Move Out": Landlords/Ladies' and Tenants' Dilemmas in the Low-income Housing Market in Accra, Ghana. *Urban Studies*, 49(14), 3177-3193. doi:10.1177/0042098012437748
- Atterhög, M., & Song, H. S. (2009). A Survey of Policies that may Increase Access to Home Ownership for Low - Income Households. *Housing, Theory and Society*, 26(4), 248-270. doi:10.1080/14036090802614479
- Bagozzi, R. P., & Yi, Y. (1988). On the Evaluation of Structural Equation Models. *Journal of the Academy of Marketing Science*, 16(1), 74-94. doi:0744/940092-0703/88 / 1601-0074
- Bian, H. (2011). *Structural Equation Modelling with AMOS II*.
- Binici, H., Aksogan, O., Bakbak, D., Kaplan, H., & Isik, B. (2009). Sound insulation of fibre reinforced mud brick walls. *Construction and Building Materials*, 23(2), 1035-1041. doi:10.1016/j.conbuildmat.2008.05.008
- Binici, H., Aksogan, O., Bodur, M. N., Akca, E., & Kapur, S. (2007). Thermal isolation and mechanical properties of fibre reinforced mud bricks as wall materials. *Construction and Building Materials*, 21(4), 901-906. doi:10.1016/j.conbuildmat.2005.11.004
- Bogdon, A. S., & Can, A. (1997). Indicators of local housing affordability: Comparative and spatial approaches. *Real Estate Economics*, 25(1), 43-80.
- Bollen, K. A. (1989). *Structural Equations with latent Variables*. New York: Willey.: New York: Willey.
- Bramley, G. (2011). Affordability, poverty and housing need: triangulating measures and standards. *Journal of Housing and the Built Environment*, 27(2), 133-151. doi:10.1007/s10901-011-9255-4
- Browne, M. W., & Cudeck, R. (1993). *Alternative Ways of Assessing Model Fit*. Newbury Park, CA: Sage.
- Chau, P. Y. K., & Hu, P. J.-H. (2001). Information Technology Acceptance by Individual Professionals: A Model Comparison Approach. *Decision Sciences*, 32(4), 699-719.
- Chen, M.-C., Tsai, I.-C., & Chang, C.-O. (2007). House prices and household income: Do they move apart? Evidence from Taiwan. *Habitat International*, 31, 243-256. doi:10.1016/j.habitatint.2007.02.005

## STRUCTURAL EQUATION MODELING OF USERS' ASSESSMENT OF AFFORDABLE HOUSING IN DEVELOPING CITIES

- Choi, J. N. (2004). Individual and Contextual Predictors of Creative Performance: The Mediating Role of Psychological Processes. *Creativity Research Journal*, 16(2 & 3), 187-199.
- Clark, W., Deurloo, M., & Dieleman, F. (2006). Residential mobility and neighbourhood outcomes. *Housing Studies*, 21(3), 323-342.
- Cohen, J. (2013). *Statistical power analysis for the behavioral sciences*: Academic press.
- Crane, M., & Warnes, A. M. (2000). Evictions and prolonged homelessness. *Housing Studies*, 15(5), 757-773.
- Creswell, J. W., & Clark, V. L. P. (2011). *Designing and conducting Mixed Methods Research* (2nd Edition ed.). California, USA: SAGE Publication.
- Davenport, J. L. (2003). *The Effect of Supply and Demand Factors on the Affordability of Rental Housing*. Available at: [http://digitalcommons.iwu.edu/econ\\_honproj/10](http://digitalcommons.iwu.edu/econ_honproj/10). Accessed 8 June 2013.
- Dawkins, C. J., & Nelson, A. C. (2002). Urban containment policies and housing prices: an international comparison with implications for future research. *Land Use Policy*, 19, 1-12.
- Ellen, I. G., Horn, K. M., & O'Regan, K. M. (2013). Why Do Higher-income Households Choose Low-income Neighbourhoods? Pioneering or Thrift? *Urban Studies*, 50(12), 2478-2495. doi:10.1177/0042098012474511
- Field, A. (2009). *Discovering Statistics Using SPSS* (Third ed.). London: SAGE Publications Ltd.
- Fisher, L. M., Pollakowski, H. O., & Zabel, J. (2009). Amenity - Based Housing Affordability Indexes. *Real Estate Economics*, 37(4), 705-746.
- George, D., & Mallery, P. (2003). *SPSS for Windows step by step: A simple guide and reference* (4th ed.): Boston: Allyn and Bacon.
- Gough, K. V., & Yankson, P. (2011). A Neglected Aspect of the Housing Market: The Caretakers of Peri-urban Accra, Ghana. *Urban Studies*, 48(4), 793-810. doi:10.1177/0042098010367861
- Hair, J. F., Black, W. C., Babin, B. J., & Anderson, R. E. (2010). *Multivariate Data Analysis: Overview of Multivariate Methods* (Seventh Edition ed.). Pearson Prentice Hall: Upper Saddle River, New Jersey: Pearson Education International.
- Hoyle, R. H. (2012). *Handbook of Structural Equation Modelling*. New York, London: The Guilford Press: A Division of Guilford Publications, Inc.
- Huang, H.-C. (2011). Factors Influencing Intention to Move into Senior Housing. *Journal of Applied Gerontology*, 31(4), 488-509. doi:10.1177/0733464810392225
- Hulchanski, J. D. (2003). *What Factors Shape Canadian Housing Policy? The Intergovernmental Role in Canada's Housing System*. Paper presented at the Municipal-Federal-Provincial Relations, Canada Queen's University, Kingston.
- Jack, E. F. (2008). Response Rates and Responsiveness for Surveys, Standards, and the Journal. *American Journal of Pharmaceutical Education*, 72(2-Article 43), 1-3.
- Joe, A. I. (1991). *Fundamental Statistics for Education and the Behavioural Sciences*. Ibadan: Crafts Books Limited.
- Jöreskog, K. G., & Sörbom, D. (1996). *LISREL 8 user's reference guide*: Scientific Software International.
- Kauko, T. (2007). An analysis of housing location attributes in the inner city of Budapest, Hungary, using expert judgements. *International Journal of Strategic Property Management*, 11(4), 209-225.
- Kline, R. B. (2011). *Principles and Practice of Structural Equation Modeling* (D. A. Kenny & T. D. Little Eds. Third ed.). New York, London: The Guilford Press: A Division of Guilford Publications, Inc.
- Kline, R. B. (2013). Assessing statistical aspects of test fairness with structural equation modelling. *Educational Research and Evaluation: An International Journal on Theory and Practice*, 19(2-3), 204-222. doi:10.1080/13803611.2013.767624
- Kutty, N. K. (2005). A new measure of housing affordability: Estimates and analytical results. *Housing Policy Debate*, 16(1), 113-142.
- Lau, K. M., & Li, S.-M. (2006). Commercial housing affordability in Beijing, 1992-2002. *Habitat International*, 30(3), 614-627.
- Lee, N. J., & Ong, S. E. (2005). Upward mobility, house price volatility, and housing equity. *Journal of Housing Economics*, 14(2), 127-146. doi:10.1016/j.jhe.2005.06.004
- Loehlin, J. C. (2004). *Latent Variable Models: An Introduction to Factor, Path, and Structural Equation Analysis* (Fourth Edition ed.). London: Lawrence Erlbaum Associates, Publishers Mahwah, New Jersey.
- Manafi, M., & Subramaniam, I. D. (2015). The Role of the Perceived Justice in the Relationship between Human Resource Management Practices and Knowledge Sharing: A Study of Malaysian Universities Lecturers. *Asian Social Science*, 11(12). doi:10.5539/ass.v11n12p131
- McQuinn, K., & O'Reilly, G. (2008). Assessing the role of income and interest rates in determining house prices. *Economic Modelling*, 25, 377-390. doi:10.1016/j.econmod.2007.06.010

- Meen, G. (2002). The Time-Series Behavior of House Prices: A Transatlantic Divide? *Journal of Housing Economics*, 11(1), 1-23. doi:10.1006/jhec.2001.0307
- Moore, E., & Skaburskis, A. (2004). Canada's increasing housing affordability burdens. *Housing Studies*, 19(3), 395-413.
- Mukiibi, S. (2012). *The Effect of Urbanisation on the Housing Conditions of the Urban Poor in Kampala, Uganda*. Paper presented at the Second International Conference on Advances in Engineering and Technology, Noida, India. Available at: <http://mak.ac.ug/documents/Makfiles/aet2011/Mukiibi>. Accessed 17 May 2014.
- Mulliner, E., Smallbone, K., & Maliene, V. (2013). An assessment of sustainable housing affordability using a multiple criteria decision making method. *Omega*, 41(2), 270-279. doi:10.1016/j.omega.2012.05.002
- Newton, P., & Meyer, D. (2010). The Determinants of Urban Resource Consumption. *Environment and Behavior*, 44(1), 107-135. doi:10.1177/0013916510390494
- NPC. (2010). *National Population Commission Official Report of 2006 Population Census Figures*. Retrieved from Abuja, Nigeria:
- Olatubara, C. O. (2007). Fundamentals of Housing. In (eds.), , pp. In T. Agbola, L. Egunjobi, & C. O. Olatubara (Eds.), *Housing Development and Management: A Book of Readings* (pp. 70-106). Nigeria.: Department of Urban and Regional Planning, Faculty of Social Science, University of Ibadan.
- Olayiwola, L. M., Adeleye, O., & Ogunshakin, L. (2005). *Public Housing Delivery In Nigeria: Problems And Challenges*. Paper presented at the World congress on Housing Transforming Housing Environments through the Design, Pretoria South Africa.
- Onibokun, P. (1985). *Housing in Nigeria: A book of Readings*. Ibadan, Nigeria: Nigerian Institute of Social and Economic Research (NISER).
- Otubu, T. (2009). *Housing Needs and Land Administration in Nigeria (Unpublished paper)*. Unpublished paper. Private and Property Law, Faculty of Law. University of Lagos, Akoka, Lagos. Lagos, Nigeria.
- Parkes, A., Kearns, A., & Atkinson, R. (2002). What makes people dissatisfied with their neighbourhoods? *Urban Studies*, 39(13), 2413-2438.
- Robinson, M., Scobie, G. M., & Hallinan, B. (2006). *Affordability of housing: concepts, measurement and evidence* (06/04). Retrieved from New Zealand:
- Sarros, J. C., Gray, J., Densten, I. L., & Cooper, B. (2005). The organizational culture profile revisited and revised: An Australian perspective. *Australian Journal of Management*, 30(1), 159-182.
- Schumacker, R. E., & Lomax, R. G. (2004). *A Beginner's Guide to Structural Equation Modeling* (D. Riegert Ed. Second Edition ed.). London: Lawrence Erlbaum Associates, Inc.
- Schumacker, R. E., & Lomax, R. G. (2010). *A Beginner's Guide to Structural Equation Modeling* (3rd Edition ed.). New York: Routledge Taylor and Francis Group, LLC.
- Shanmugapriya, S., & Subramanian, K. (2013). Investigation of Significant Factors Influencing Time and Cost Overruns in Indian Construction Projects. *International Journal of Emerging Technology and Advanced Engineering*, 3(10), 734-740.
- Sinai, T., & Souleles, N. S. (2003). *Owner-occupied housing as a hedge against rent risk*. Available at: <http://www.nber.org/papers/w9462>. Accessed 15 August 2013.
- Snively, S. (2009). *What is housing – (consumption good, investment good, asset class, industry, infrastructure), and, what role does it play as an automatic stabilizer*. Paper presented at the Workshop on After the Boom – Where to From Here, Reserve Bank of New Zealand.
- Stone, M. E. (1993). *Shelter Poverty: New ideas on Housing Affordability*. Philadelphia: Temple University Press.
- Stone, M. E. (2006). A housing affordability standard for the UK. *Housing Studies*, 21(4), 453-476.
- Tan, T.-H. (2012). Meeting first-time buyers' housing needs and preferences in greater Kuala Lumpur. *Cities*, 29(6), 389-396. doi:10.1016/j.cities.2011.11.016
- Tanguma, J. (2001). Effects of sample size on the distribution of selected fit indices: A graphical approach. *Educational and Psychological Measurement*, 61(5), 759-776.
- Tu, Y., & Goldfinch, J. (1996). A two-stage housing choice forecasting model. *Urban Studies*, 33(3), 517-537.
- UN-Habitat. (2011). *United Nations Human Settlements Programme: Africa Affordable Land and Housing for a better urban future 2012*. Available at: <http://www.unhabitat.org>. Accessed 28 May 2013.
- Wang, D., & Li, S.-m. (2006). Socio-economic differentials and stated housing preferences in Guangzhou, China. *Habitat International*, 30(2), 305-326. doi:10.1016/j.habitatint.2004.02.009
- Wheaton, W. C. (1990). Vacancy, Search, and Prices in a Housing Market Matching Model. *Journal of political Economy*, 98(6), 1270-1292.
- Wong, P. S. P., & Cheung, S. O. (2005). Structural Equation Model of Trust and Partnering Success. *Journal of Management in Engineering*, 21, 70-80. doi:10.1061//asce/0742-597x/2005/21:2/70

- Yang, Y. (2008). A Tale of Two Cities: Physical Form and Neighborhood Satisfaction in Metropolitan Portland and Charlotte. *Journal of the American Planning Association*, 74(3), 307-323. doi:10.1080/01944360802215546
- Yates, J. (2008). Australia's housing affordability crisis. *Australian Economic Review*, 41(2), 200-214.
- Yusuf, A. A., & Resosudarmo, B. P. (2009). Does clean air matter in developing countries' megacities? A hedonic price analysis of the Jakarta housing market, Indonesia. *Ecological Economics*, 68(5), 1398-1407.
- Zabel, J. E., & Kiel, K. A. (2000). Estimating the demand for air quality in four US cities. *Land Economics*, 174-194.

***Modelowanie równań strukturalnych oceny użytkowników tanich mieszkań w rozwijających się miastach***

***Streszczenie***

W toku badań zbadano ocenę tanich mieszkań w rozwijających się miastach wśród mieszkańców centrum miasta Ibadan. Tanie mieszkalnictwo dotyczy użytkowników mających dostęp do dobrych pod względem jakości mieszkań po rozsądnych cenach, otrzymanie ich, utrzymanie zdolności do pokrycia innych podstawowych kosztów życia i mieszkania bez żadnego problemu w celu promowania dobrego zdrowia, dostępności, wygody i środowiska, bez przestępczości i przemocy. W artykule opracowano model teoretyczny, który łączy ocenę użytkowników z przystępnymi warunkami mieszkaniowymi. Kwestionariusz został opracowany i przekazany 494 mieszkańcom w pięciu samorządowych obszarach w Ibadanie. Dane przeanalizowano za pomocą pakietów statystycznych SPSS i AMOS w wersji 22. Zastosowano analizę czynnikową, aby określić ocenę użytkowników tanich mieszkań. Modelowanie równań strukturalnych jako narzędzia pomiarowe zastosowano do walidacji modelu teoretycznego. Wskazało ono, że szczegółowe badanie, ocena i krytyczne opinie użytkowników na temat ich przystępnych cenowo mieszkań to ważny krok w kierunku opracowania polityki mającej na celu poprawę taniego mieszkalnictwa dostępnego dla użytkowników. Autorzy są zdania, że strategia zastosowania odpowiedniej polityki mieszkaniowej jest potrzebna, aby sprostać wyzwaniu tworzenia zasobu mieszkaniowego po przystępnych cenach w rozwijających się miastach.

***Słowa kluczowe:*** tanie mieszkalnictwo, analiza czynnikowa, rozwój, modelowanie równań strukturalnych, ocena użytkowników