

THE NEW JAPANESE HOUSING POLICY AND RESEARCH AND DEVELOPMENT TO PROMOTE THE LONGER LIFE OF HOUSING

Minami, Kazunobu

*Department of Architecture
Shibaura Institute of Technology
Tokyo, Japan*

ABSTRACT

The new law which promotes the longer life of housing in Japan passed the Upper House of the Japanese Parliament on October 28, 2008. In the author's last paper for CIB W104 in Noordwijk in October 2009, the technical guidelines of the new law were introduced. In this paper, the author explains the outline of the ongoing research and development to prolong the life of apartment buildings in Japan which follows the establishment of the new law.

Keywords: housing policy, long-life of housing, occupancy records, adaptability, infill improvements

INTRODUCTION

The average life time of newly-built detached wooden houses in Japan was almost fifty years. There are various reasons for the short life span of Japanese housing. Fires following the Great Kanto Earthquake that struck the Tokyo area in 1912 caused a huge loss of building stock, so only a small amount of old houses remain in the Tokyo Metropolitan area. The rapid economic growth that followed the Second World War enabled the Japanese to afford to live in larger houses with modern facilities. Many people rebuilt their smaller temporary houses built just after the end of the war.

Present-day Japan faces three problems: 1) people cannot enjoy the feeling of wealth they should as members of a mature society, 2) the falling birth rate and aging of society are increasing the welfare burden, and 3) global environmental problems and waste problems are becoming increasingly severe. To overcome these problems we must transform society from its existing state, a consumption society which builds and demolishes, into a stock society which builds good objects and takes scrupulous care of them to preserve them for long periods of time. The goal of extending the life span of housing is to overcome these problems.

The new law which promotes the longer life of housing in Japan passed the Upper House of the Japanese Parliament on October 28, 2008, following deliberations in the Lower House in the preceding week. The concept of this law was presented by former Prime Minister Yasuo Fukuda in 2007. The Law started its implementation on June 4th, 2009. The Government started the pilot projects in 2009 by subsidizing the private sectors' R&D to make the housing in Japan longer (200 Million Euro a year). The new law aims to supply long-life housing in Japan from now on, in addition to using the existing houses much longer.

Technical guidelines of the new law

In the author's last paper for CIB W104 in Noordwijk in October 2009, the technical guidelines of the new law were introduced. The technical guidelines explain the technical details required for extending the life span of housing. There are nine chapters in the technical guidelines, and an appendix as;

Chapter 1. Durability of the material; Deterioration measures;

House structures should be able to be used for several generations. They should be designed so that the period their structure can be used continually under maintenance conditions considered normal is at least 100 years. It should be counted on to be usable for between 150 and 200 years under appropriate maintenance.

Example: In the case of reinforced concrete (RC) construction, one of the following types of design should be taken.

- Water cement ratio of 45% or lower.
- Water cement ratio of 50% or lower and covering thickness (of concrete) increased by 1 cm.

Chapter 2. Structural design; Earthquake resistance

Make it easier to repair damage caused by an extremely uncommon earthquake to ensure the continuous use of the house by reducing the level of damage caused by earthquakes.

Either build it as a base-isolated building or take measures to reduce deformation caused by large earthquake force at or below a specified level.

Example: The ratio of the safety limit deformation of each above-ground story to its height should be 1/100 or less (in the case of wooden construction, 1/40 or less) during a large-scale earthquake.

Chapter 3. Ease of maintenance and renewal

Measures necessary so that the maintenance (cleaning, inspection, repair and update) of the interior finishing and facilities which have shorter life spans than the building structures can be carried out easily should be taken.

- The building should be designed so that private piping and common piping are easily maintained (Figure 1).
- The building should be designed so that common drainage pipes are easily maintained. It shall be possible to maintain common piping of condominium apartments without entering private parts of dwellings (Figure 2).

Chapter 4. Adaptability

Measures should be taken which permit the modification of room layouts according to changes in the lifestyle of the occupants. Ceiling height of the building frame must be adequate for piping and wiring according to modification of the original room layouts.

Example: A specified building frame ceiling height or higher (2,650mm or higher) must be ensured.

Chapter 5. Universal design for the elderly and handicapped

Necessary space in common halls and corridors must be maintained so that it is possible to perform renewal work to make a home barrier free in the future.

Example: The width etc. of common halls and corridors must be designed to ensure necessary space.

Chapter 6. Energy efficiency; Energy conservation

The performance of the insulation etc. must ensure energy conservation.

Chapter 7. Floor space for each unit

Sufficient space must be secured to ensure the occupants have reasonable levels of living standards.

Chapter 8. Living environment

The maintenance and the improvement of the living environment and the landscape in the surrounding area.

Chapter 9. Long-term maintenance planning

- 1) Elements necessary for structural resistance,
- 2) Parts which prevent the infiltration of rainwater, and
- 3) Water supply and water drainage systems.

The inspection details and periods for the above items must be contained in the maintenance plans.

□ Inspections must be performed at least once every 10 years

Appendix: documentation and house records

Detail of Piping Space in a Private Dwelling + Rule for Maintenance & Repair

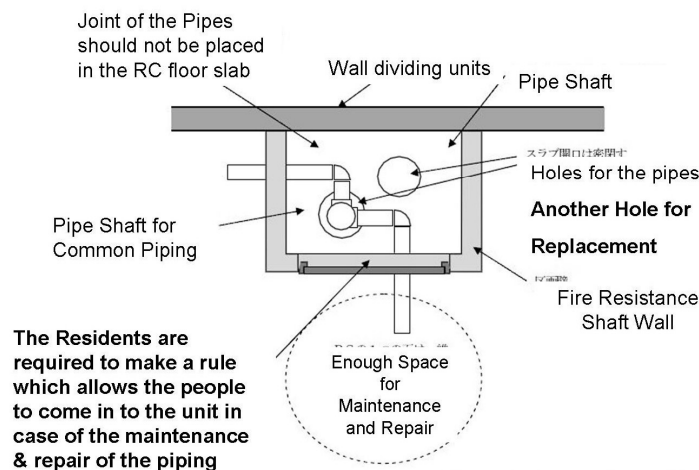

Figure 1. The requirements for piping space in a private condominium dwelling

without entering private parts of dwellings, but...

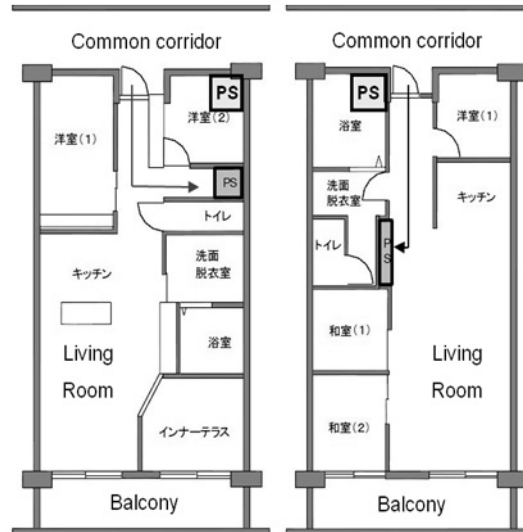

Figure 2. The common piping of condominium apartments that can be maintained without entering private parts of dwellings.

Incentive for longer life housing

The client can apply for tax reductions and can receive subsidies by designing and building a house which complies with the new law and technical guidelines. Specific incentive measures have been implemented. 1) When a person has purchased or constructed and occupied long-life-span superior housing from 2009 to 2011, the person is exempt from income tax up to a maximum value of 6 million yen over a ten year period according to the balance of the person's housing loan at the end of each year. 2) When a person has purchased or constructed and occupied long-life-span superior housing, the person receives an income tax exemption equal to 10% of the construction cost which exceeds that of ordinary housing (limited to 10 million yen). 3) The fixed asset tax on long-life-span superior housing is reduced by 1/2 for two years longer than in the case of ordinary housing.

Implementation of the new law to make the life of Japanese housing longer

38,568 housing units have been recognized as long-life housing based on the new law as at the end of 2009 after the enforcement of the law on June 4, 2009. These include 38,029 detached houses and 539 condominiums. As not many condominium developers think that the recognition as long-life housing has much to do with sales promotion, applications for condominiums have been very small. On the other hand, developers of detached houses have taken much advantage of the recognition as long-life housing, and have utilized it for their advertising and sales promotion. The technical guidelines which require that the common equipment piping in the condominium can be maintained without entering the unit make application for condominiums very small (Figure 2). This requirement for condominiums may need to be revised to increase application of the new law.

Governmental support for local small and medium-sized house builders

Most of the detached wooden houses in Japan are built and supplied by local small and medium-sized house builders. Therefore, it will be necessary to provide various supports to small and medium-sized house builders in order to achieve long-life housing in Japan. The government has begun to subsidize at the most 10 percent of the construction cost or up to one million yen for long-life housing that will be constructed by small or medium-size house builders which construct less than 50 units per year. To obtain the subsidy, the housing must meet the requirements of the new law and the technological guidelines, the necessary information concerning the design and maintenance of the housing must be kept, and information concerning the construction process must be publicly disclosed.

Promotion of research and technological development to achieve long-life housing by the private sector

The Ministry of Land, Infrastructure, Transport and Tourism is developing technologies which achieve long-life housing in addition to the enactment of the new law and has started a pilot project inviting the participation of the private sector. This pilot project is based on the idea of “making high quality housing, maintaining it neatly, and using it for long.” There are five categories in this project where applications can be made: “design and construction of a newly-built house;” “repair and maintenance technology of an existing house;” “establishment of the circulation system of an existing house;” “evaluation of developed technologies;” and, “publicity and enlightenment.” 70 percent of the submitted proposals were concerning “design and construction of a newly-built house,” and the large majority was about detached houses. There have only been a small number of proposals concerning condominiums up to now.

The government believes that it is important to entirely reorganize the housing industry in order to better produce and maintain housing, to enhance research and development - especially for condominium housing, and to promote the technological development concerning the repair and maintenance of existing housing. It is also important to consider the uniqueness of local areas and to develop technologies respecting the unique characteristics of each region.

In the U.S. and the E.U., over 70 to 90 percent of houses supplied are secondhand houses, but in Japan, this number is only around 13 percent. The proportion of housing maintenance and improvement in all residential investment in Japan is much smaller than that of America and European countries. It is considered that the amount of housing investment per 1000 of the population in the U.S. and European countries exceeds that in Japan because of the scale of the reform investment. It is expected that the repair and maintenance of housing in Japan will increase in the near future. Technological development concerning the renewal of the infill of condominium housing is indispensable to increasing Japanese housing life.

Government agency research and development

The National Institute for Land and Infrastructure Management started a three year research project to develop long-life housing, and invited researchers from universities to participate. The project has the following four main research topics.

1. The design approach of long-life housing that can be used over several generations.
2. Repair and renewal technologies and deterioration diagnosis technology of existing housing.

3. Management technology for housing which is to be lived in over several generations.
4. Earthwork technology of residential lots.

The changeability and the size of unit divisions are studied in order to design long-life condominiums. The following design methods are studied.

1. The variability of the dwelling unit size according to the changes of needs for housing (Figure 3 above)
2. Changeability of use from a house to an institution (Figure 3 below)
3. Adaptability of common spaces, such as corridors and balconies

In Japan, while analyzing design examples where changeability of unit divisions is implemented, research is also being undertaken regarding associated legal and economical problems.

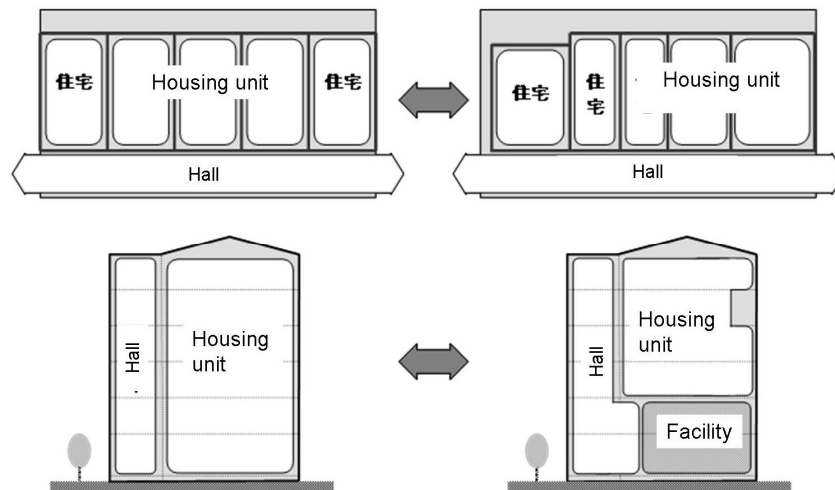

Figure 3. Example image of a variable dwelling unit and the changes of use.

Above:

The changeability of the dwelling unit size by the movement of the boundary wall

The variability of the balcony by the movement of the outer wall

Below:

The changeability of the ceiling height of the dwelling unit by the removal of the floor slab

The variability of the width of the outside corridor by the movement of the outer wall

CONCLUSIONS

The approach toward lengthening housing life in Japan longer has only just begun. Real results of design methods and technological developments already started have not yet been seen. Although not enough research on the relationship between city planning and building life span has been conducted, it seems that there is a strong relationship in regard to the development of post-war Japanese cities. Again, not enough research has yet been conducted regarding the influence of social systems such as the inheritance tax system on the longevity of a house. The lengthening of the life of a house is believed to be useful to reduce the consumption of natural resources and the economical burden of housing expenses for families. Therefore, wide-ranging research including the improvement of social systems is necessary to achieve the objectives of the housing policy in Japan.